

Annual Report
Jahresbericht

2024

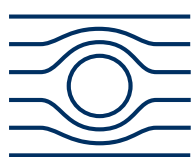
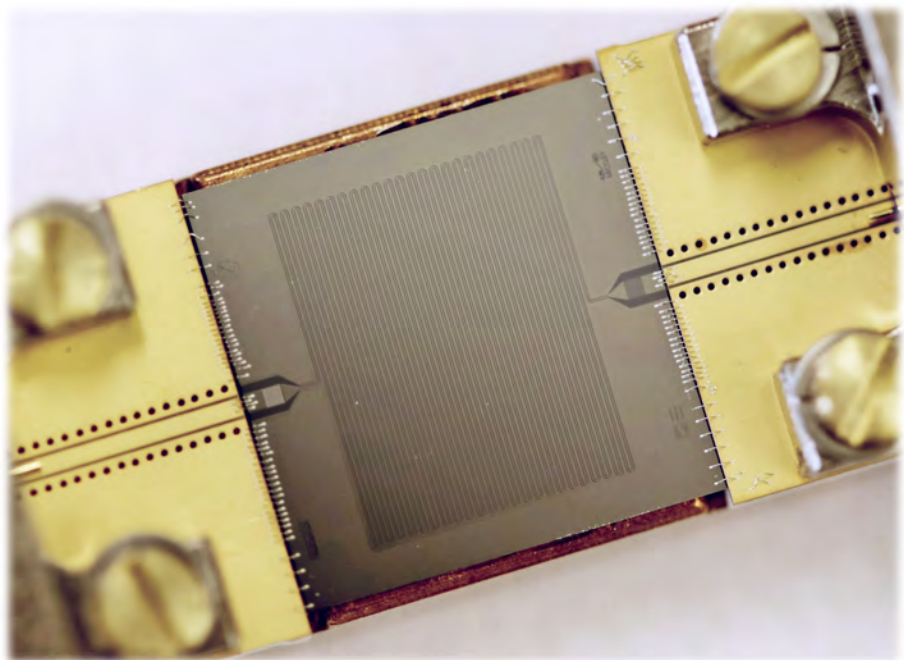

Walther-Meißner-Institut

DER BAYERISCHEN AKADEMIE DER WISSENSCHAFTEN

Cover photo: package of a superconducting transmission line
©Walther-Meißner-Institut / Nadezhda Kukharchyk

Contact:

Prof. Dr. Stefan Filipp, Prof. Dr. Rudolf Gross, and Prof. Dr. Peter Rabl
Walther-Meißner-Institut für Tieftemperaturforschung
Bayerische Akademie der Wissenschaften

Address:

Walther-Meißner-Str. 8	e-mail: Stefan.Filipp@wmi.badw.de
D - 85748 Garching	e-mail: Rudolf.Gross@wmi.badw.de
GERMANY	e-mail: Peter.Rabl@wmi.badw.de
	www: https://www.wmi.badw.de

Secretary's Office and Administration:

Emel Dönertas	Phone: +49 – (0)89 289 14202
	Fax: +49 – (0)89 289 14206
	e-mail: Sekretariat@wmi.badw.de



Walther-Meißner-Institut

DER BAYERISCHEN AKADEMIE DER WISSENSCHAFTEN

Preface

Dear colleagues, friends, partners, and alumni of the Walther-Meißner-Institute (WMI),

As documented in this Annual Report, the eventful, successful, yet at times challenging year of 2024 has come to an end. On behalf of the entire board of directors, I would like to take this opportunity to express my sincere gratitude to everyone for their continued contributions to the scientific and technological advancements of the institute. Special thanks go to the technical and administrative staff of the WMI for their dedicated and professional support throughout the whole year, without which this progress would not have been possible.

Although at a slower pace, the institute continued to grow in 2024 in terms of research infrastructure, third-party funding, and scientific personnel. I would like to warmly welcome everyone who has joined the WMI over the past year. I am particularly excited to see that approximately 45 Ph.D. students and more than 25 master's and bachelor's students are currently conducting their research at our institute. These numbers highlight the important role of the WMI in training talented young scientists in the fields of low-temperature physics and quantum technologies. I am also very pleased to announce that, following a transition period in 2023, my own group has expanded significantly over the past months, and that the new Quantum Theory Division is finally 'up and running'. On the occasion of his retirement at the end of 2024, I would like to congratulate Mark Kartsovnik on an outstanding scientific career and thank him for his year-long commitment and hard work for the institute.

In 2024, the WMI continued its success in acquiring third-party funding, such as the BMBF project "QuantumSPICE," and further strengthened its prominent role in various regional and national collaborative research initiatives. Notably, this includes the Munich Quantum Valley (MQV), where, during the transitional period of 2023/2024, Prof. Rudolf Gross served as the Scientific and Managing Director. He devoted considerable time and personal commitment to navigating this flagship project of the Hightech Agenda Bavaria through both calm and stormy waters. In 2024, many of the initial investments in fabrication infrastructure began to yield significant results. In particular, with the development of new quantum chips by Prof. Stefan Filipp and his team, the WMI established itself as a key contributor to MQV and as a leading institute in the field of superconducting quantum technologies with increasing international visibility. Together with Kirill Fedorov, Hans Hübl, Nadezhda Kukharchyk, Stefan Filipp, Rudolf Gross, and myself, the WMI has further increased its engagement in the Cluster of Excellence "Munich Center for Quantum Science and Technology (MCQST)." The review meeting for the upcoming funding period (2026–2032) of MCQST was held in November in Bonn. While the final decision from the DFG is still pending, I am highly optimistic about the continuation of the cluster, with a significant contribution from WMI.

As a particular highlight of the past year, Matthias Althammer received the ERC Consolidator Grant for his project "Pseudospin-based Antiferromagnetic Magnonics (POSA)." This prestigious and highly competitive grant, awarded by the European Commission for groundbreaking basic research, has been granted for the first time to a member of the WMI. I would like to congratulate Dr. Althammer for this amazing achievement!

Another milestone in 2024, unprecedented in the history of the institute, was the founding of the startup company "Peak Quantum GmbH" by a team of former and current PhD students of WMI. The spin-off aims to commercialize the design and fabrication of advanced superconducting quantum circuits for applications in basic research and quantum information processing, directly benefiting from the available scientific expertise at WMI and the broader Munich quantum ecosystem. I look forward to many fruitful collaborations between Peak Quantum and the WMI and commend the founders for taking this courageous step. Hopefully, it will

develop into a role model for how basic research can translate into industrial applications and create broader benefits for society.

While these exciting developments and the continued growth of the institute are highly encouraging, they have also led to an increasing scarcity of office space at the WMI over the past few years. I am therefore especially pleased to announce that in December 2024, just before the Christmas break and following numerous delays and bureaucratic hurdles, the WMI finally received a much-needed extension in the form of a modular office building located next to the main institute. These 'containers' provide high-quality office space for nearly 40 people, along with additional seminar and discussion rooms. This expansion will alleviate the currently tight office space situation in the main building and provide additional opportunities for lectures, meetings, and collaborations. Representative for everyone who has been involved in this project, I would like to thank Achim Marx for his immense dedication and for managing all the bureaucratic processes over the course of more than two years.

Despite such complications and many other little setbacks that we faced day to day, this Yearly Report highlights that in 2024, the WMI continued its long-term upward trajectory, building on the success it has sustained over many years. Therefore, I am very optimistic as I look forward to the years ahead. With the retirement of Prof. Rudolf Gross and the upcoming announcement of a new director position in 2025, the coming years will undoubtedly bring further changes, but, more importantly, many exciting new opportunities for the development of the institute. Proclaimed as the International Year of "Quantum Science and Technology," 2025 holds a specific significance for the WMI, where quantum science not only has a long history but also remains its primary research focus today. Already in 2024, during the open-door days of the BAdW and Campus Garching, we all witnessed the overwhelming interest the general public has in topics such as superconductivity and quantum technologies. Therefore, 2025 should serve as a particular motivation for all of us to continue and expand these outreach activities, explaining to schoolchildren, adults, and local and national policymakers the fascinating physical phenomena that we study at our institute every day.

To sum up, it has been a great year, and once again, I would like to thank the scientific, technical, and administrative staff of WMI for their personal commitment and outstanding performance in 2024! I would also like to extend my gratitude to our Scientific Advisory Board for their trust and guidance and, last but not least, to all our sponsors and funding agencies for their continued financial support. Let us carry forward this spirit into 2025!

With my very best regards,



Garching, December 2024

Contents

- Preface 1
- The Walther–Meißner–Institute 7
- New Developments: 11**
- Building Projects & New Infrastructure 11**
- Modular Office Building 13
- Collaboration with the Semiconductor Laboratory of the Max Planck Society 14
- High-Density Wiring Upgrade for Two Bluefors XLD1000 Systems to Support Mid-
 to Large-Scale Quantum Processors 16
- Fast-Cycling Cryostats for Rapid Prototyping and Characterizations 17
- Entrepreneurship 19**
- WMI Announces New Spin-Off Company: Peak Quantum GmbH 21
- Joint Research Projects: 23**
- MCQST - an Ongoing Success Story in Quantum Science 25
- Successful Starting Phase of Munich Quantum Valley 29
- A 17-Qubit Quantum Computing Demonstrator Built within the Projects GeQCoS,
 MUNIQC-SC and MQV 33
- The BMBF-Funded Project QuantumSPICE 35
- Scientific Reports: 37**
- Highlights 37**
- Research Highlights 39
- Basic Research 41**
- Semiclassical Simulations of Dissipative Spin Systems 43
- A Bosonic Cascade Laser 45
- Bosonic and Fermionic Impurity Models in Circuit QED 47

Impact of Growth Conditions on Magnetic Anisotropy and Magnon Hanle Effect in α -Fe ₂ O ₃	49
Electrically Induced Angular Momentum Flow between Separated Ferromagnets . . .	51
Resonant Magneto-Elastic Coupling in Cobalt/Iron Thin Film - Sapphire Substrate Bilayers	53
High-Precision Broadband ESR Spectroscopy of Rare-Earth Ions in CaWO ₄	55
Electronic System of the Spin-Liquid Candidate κ -(BEDT-TTF) ₂ Cu ₂ (CN) ₃ on the Verge of the Metal-Insulator Transition	57
Application–Oriented Research	59
Thermal Entanglement Distribution	61
Towards Microwave Hybrid Entanglement	63
Microwave Entanglement Distribution over Thermal Communication Channels	65
Machine Learning for Quality Factor Estimation in Superconducting Resonators . . .	67
Scaling of Superconducting Qubit Architectures: Development and Realization of a 17-Qubit QPU	69
Extending Remote Access to Multiple Quantum Processors	71
Impedance-Matched Broadband Josephson Parametric Amplifier	73
Protected Fluxonium Control with Sub-harmonic Parametric Driving	75
Sub-harmonic Driving via Multi-Photon Processes in Superconducting Qubits	77
Towards Storage of Squeezed States in Spin Ensembles	79
Robust Single-Qubit Gates	81
Mitigating Phase Velocity Mismatch in Flux-Pumped Josephson Traveling Wave Parametric Amplifiers	83
Materials, Thin Film and Nanotechnology, Experimental Techniques	85
Progress in High Coherence Qubit Fabrication	87
3D Integration of Superconducting Resonators	89
Josephson Junction Annealing for Improved Frequency Targeting	91
Statistics:	93
Appointments, Honors & Awards	95
Hans Hübl is Appointed Adjunct Professor at TUM	95
Prestigious ERC Consolidator Grant Awarded to Dr. Matthias Althammer	97
Publications	99
Books	104
Bachelor, Master, Doctoral, and Habilitation Theses	105

Research Projects	113
Conferences, Workshops, Public Engagement, Collaborations, Research Stays, etc.	117
Invited Conference Talks and Seminar Lectures	125
Membership in Advisory Boards, etc.	132
Teaching:	135
Lectures, Courses and other Teaching Activities	137
Staff:	141
Staff of the Walther-Meißner-Institute	143
Guest Researchers	145
Scientific Advisory Board and Executive Committee:	147
Scientific Advisory Board	149
Executive Committee	150

The Walther–Meißner–Institute

The *Walther-Meißner-Institute for Low Temperature Research (WMI)* was originally operated by the Commission for Low Temperature Research of the *Bavarian Academy of Sciences and Humanities (BAdW)*. Between 2013 and 2015, the Bavarian Academy of Sciences and Humanities with its more than 300 employees was reorganized. With the passing of the new statutes in October 2015, the 36 Commissions (Research Groups) of the Academy were suspended. The



research program of BAdW is now implemented in Academy Institutes, such as the Walther-Meißner-Institute, the *Leibniz Supercomputing Centre (LRZ)* or the *Bavarian Research Institute for Digital Transformation (BIDT)*, and Academy Projects. The Academy Institutes and Projects are managed by the Institute and Project Committees and supervised by the Institute and Project Advisory Boards, respectively. In this way a clear separation between the managing bodies of the institutes/projects (responsible for the implementation of the research programs) and the corresponding supervisory bodies (responsible for the quality control) was established. To this end, also the Commission for Low Temperature Research was dissolved and replaced by the WMI Committee and the WMI Advisory Board in 2015.

The historical roots of WMI go back to *Walther Meißner*. He founded the Commission for Low Temperature Research in 1946 when he was president of BAdW (1946 – 1950). The first research activities then were started in 1946 in the Herrsching barracks. After the retirement of Walther Meißner in 1952, Heinz Maier-Leibnitz, who followed Walther Meißner on the Chair for Technical Physics of the Technical University of Munich (TUM), became the new head of the Commission for Low Temperature Research. In 1967, the commission moved to the Garching research campus after the construction of the new «*Zentralinstitut für Tieftemperaturforschung*» (ZTTF) was completed (director: Prof. Heinz Maier-Leibnitz, technical director: Prof. Franz Xaver Eder). Until 1972, the theory group of the Institute Laue Langevin was hosted at the ZTTF with prominent members such as Peter Fulde. In 1980, Prof. Dr. Klaus Andres became the new director of the ZTTF again associated with the Chair for Technical Physics (E23) at TUM. In 1982, the ZTTF was renamed into Walther-Meißner-Institute for Low Temperature Research (WMI) on the occasion of the 100th anniversary of Walther Meißner's birth.

In 2000, Prof. Dr. Rudolf Gross followed Klaus Andres on the Chair for Technical Physics (E23) at TUM and as the new director of WMI. He extended the scientific focus of WMI by starting new activities in the field of quantum science and technology, as well in magnetism, spin dynamics and spin electronics. Moreover, he established the materials technology for superconducting and magnetic materials (both in form of thin films and single crystals) and a clean room facility, allowing for the fabrication of solid-state nanostructures.

Due to the strong increase of staff, research projects and administrative tasks the governance structure of the WMI was changed in 2019 from a single director to a board of up to three directors headed by a managing director. The implementation of the structural change started in June 2020 with the nomination of Prof. Dr. Stefan Filipp as the second scientific director of the WMI. His research is focused on superconducting quantum circuits and in particular on

quantum computing and quantum simulation. In February 2023, Prof. Dr. Peter Rabl started as the third scientific director of the WMI with his group working on applied quantum theory.

The WMI has been playing a leading role in several coordinated research projects in the field of nanosciences with the Cluster of Excellence Nanosystems Initiative Munich from 2006 to 2019 and in the field of quantum science and technology with the Collaborative Research Center 631 on Solid-State Quantum Information Processing (2003-2015), the Cluster of Excellence *Munich Center for Quantum Science and Technology* (since 2019) and the EU Quantum Technology Flagship Project QMiCS (2018-2022). The WMI has recently also played a leading role in initiating the *Munich Quantum Valley* in 2020 (see strategy paper «*Munich Quantum Valley Initiative*»). It is now coordinating and participating in several national and European consortia, such as the *German Quantum Computer based on Superconducting Qubits (GeQ-CoS)* and the *Munich Quantum Valley Superconducting Quantum Computing Demonstrator (MUNIQC-SC)* projects, to develop quantum computing technologies based on superconducting quantum circuits.

To accommodate the activities, the infrastructure of the WMI has been constantly renewed and upgraded. Starting from 2000 the so far unused basement of the WMI building was made available for technical infrastructure (air conditioning, particulate air filters, pure water system etc. for clean room) and additional laboratory space. Fortunately, in 2008 WMI succeeded in getting extra money from the state government within the so-called «*Konjunkturpaket II*» to establish the new «*WMI Quantum Science Laboratory*» in the basement of the building, providing about 150 m² additional laboratory space particularly suited for low-temperature facilities and ultra-sensitive studies on solid-state quantum systems. In 2016, the Bavarian Ministry for Science and Arts granted more than 6 Mio. Euro for redevelopment measures regarding the technical infrastructure, safety requirements and energy efficiency. An important part of the building project implemented in 2017/18 was the reconstruction of the entrance area and the main staircase, providing now direct access to the new WMI Quantum Laboratories in the basement of the WMI building, as well as additional communication areas and meeting rooms in the ground floor. Moreover, it included the replacement of all windows and doors, the upgrade of the technical infrastructure for cooling water, air conditioning, liquid nitrogen and helium storage, as well as the complete redevelopment of the mechanical workshop and various safety measures. With the intense activities in the field of quantum computing and the new groups starting in 2020 and 2023 offices and laboratories have been renovated and repurposed to host the new infrastructure for fabricating and characterizing scalable quantum processors. Aside from the upgrades of the pure water system, the air conditioning system and the cooling units, a new modular office building is planned to provide more office space starting from 2024.

While the WMI traditionally hosts the Chair for Technical Physics (E 23) of the Technical University of Munich (TUM) the WMI has established tight links to research groups of both Munich universities, joining technological and human resources in the fields of experimental and theoretical solid-state and condensed matter physics, quantum technologies, low-temperature techniques, materials science as well as thin film and nanotechnology. Noteworthy is that the WMI supplies liquid helium to more than 25 research groups at both Munich universities and provides the technological basis for low-temperature research.

Important Discoveries

The WMI looks back on a long history of successful research in low-temperature physics. In the following we list some important discoveries as well as experimental and technical developments made at WMI:

- **1961: discovery of flux quantization in multiply connected superconductors**
(R. Doll, M. Näbauer, *Experimental Proof of Magnetic Flux Quantization in a Superconducting Ring*, *Phys. Rev. Lett.* **7**, 51-52 (1961)).
- **1986: discovery of an anomalous temperature dependence of the penetration depth in UBe₁₃**
(F. Gross, B.S. Chandrasekhar, D. Einzel, K. Andres, P.J. Hirschfeld, H.R. Ott, J. Beuers, Z. Fisk, J.L. Smith, *Anomalous Temperature Dependence of the Magnetic Field Penetration Depth in Superconducting UBe₁₃*, *Z. Physik B - Condensed Matter* **64**, 175-188 (1986)).
- **1992: discovery the intrinsic Josephson effect**
(R. Kleiner, F. Steinmeyer, G. Kunkel, and P. Müller, *Intrinsic Josephson Effects in Bi₂Sr₂CaCu₂O₈ Single Crystals*, *Phys. Rev. Lett.* **68**, 2394-2397 (1992)).
- **2002: development of dilution refrigerators with pulse tube refrigerator precooling**
(K. Uhlig, ³He/⁴He Dilution Refrigerator with Pulse Tube Precooling, *Cryogenics* **42**, 73-77 (2002)).
- **2010: first demonstration of ultrastrong light-matter interaction**
(T. Niemczyk, F. Deppe, H. Huebl, E. P. Menzel, F. Hocke, M. J. Schwarz, J. J. Garcia-Ripoll, D. Zueco, T. Hümmer, E. Solano, A. Marx, R. Gross, *Circuit Quantum Electrodynamics in the Ultrastrong-Coupling Regime*, *Nature Physics* **6**, 772-776 (2010)).
- **2010: development of dual path method for state tomography of propagating quantum microwaves**
(E.P. Menzel, M. Mariantoni, F. Deppe, M.A. Araque Caballero, A. Baust, T. Niemczyk, E. Hoffmann, A. Marx, E. Solano, R. Gross, *Dual-Path State Reconstruction Scheme for Propagating Quantum Microwaves and Detector Noise Tomography*, *Phys. Rev. Lett.* **105**, 100401 (2010)).
- **2012: first realization of path entanglement of propagating quantum microwaves**
(E. P. Menzel, R. Di Candia, F. Deppe, P. Eder, L. Zhong, M. Ihmig, M. Haerberlein, A. Baust, E. Hoffmann, D. Ballester, K. Inomata, T. Yamamoto, Y. Nakamura, E. Solano, A. Marx, R. Gross, *Path Entanglement of Continuous-Variable Quantum Microwaves*, *Phys. Rev. Lett.* **109**, 250502 (2012)).
- **2013: discovery of the spin Hall magnetoresistance** (jointly with partners at Tohoku University and TU Delft)
(H. Nakayama, M. Althammer, Y.-T. Chen, K. Uchida, Y. Kajiwara, D. Kikuchi, T. Ohtani, S. Geprägs, M. Opel, S. Takahashi, R. Gross, G. E. W. Bauer, S. T. B. Goennenwein, E. Saitoh, *Spin Hall Magnetoresistance Induced by a Non-Equilibrium Proximity Effect*, *Phys. Rev. Lett.* **110**, 206601 (2013)).
- **2013: first demonstration of strong magnon-photon coupling**
(H. Huebl, Ch. Zollitsch, J. Lotze, F. Hocke, M. Greifenstein, A. Marx, R. Gross, S.T.B. Goennenwein, *High Cooperativity in Coupled Microwave Resonator Ferrimagnetic Insulator Hybrids*, *Phys. Rev. Lett.* **111**, 127003 (2013)).
- **2017: first experimental observation of the spin Nernst effect**
(S. Meyer, Yan-Ting Chen, S. Wimmer, M. Althammer, S. Geprägs, H. Huebl, D. Ködderitzsch, H. Ebert, G.E.W. Bauer, R. Gross, S.T.B. Goennenwein, *Observation of the spin Nernst effect*, *Nature Materials* **16**, 977-981 (2017)).
- **2019: first demonstration of remote state preparation in the microwave regime**
(S. Pogorzalek, K. G. Fedorov, M. Xu, A. Parra-Rodriguez, M. Sanz, M. Fischer, E. Xie, K. Inomata, Y. Nakamura, E. Solano, A. Marx, F. Deppe, R. Gross, *Secure Quantum Remote State Preparation of Squeezed Microwave States*, *Nature Communications* **10**, 2604 (2019)).

- **2021: first demonstration of quantum teleportation in the microwave regime**

(K. G. Fedorov, M. Renger, S. Pogorzalek, R. Di Candia, Q. Chen, Y. Nojiri, K. Inomata, Y. Nakamura, M. Partanen, A. Marx, R. Gross, F. Deppe, *Experimental quantum teleportation of propagating microwaves*, *Science Advances* 7, eabko891 (2021)).

Present Research Activities

The research activities of the Walther-Meißner-Institute focus on low-temperature condensed matter and quantum physics, as delineated in the reports in the following sections. Broadly speaking, the research program is centered on **fundamental** and **applied research** topics and also addresses **materials science**, **thin film and nanotechnology** aspects. It conducts research in the field of low and ultra-low-temperature physics with a special focus on quantum systems, quantum computing, superconductivity and correlated electron systems, as well as magnetism and spintronics.

The WMI also develops and operates systems and techniques for low and ultra-low-temperature experiments. A successful development has been dry mK-systems that can be operated without liquid helium by using a pulse-tube refrigerator for pre-cooling. In the early 2000s, these systems have been successfully commercialized by the company VeriCold Technologies GmbH at Ismaning, Germany, which was taken over by Oxford Instruments in 2007. Currently, in a collaboration with Oxford Instruments such dry dilution refrigerators are used to establish a so-called cryolink, allowing for quantum communication in the microwave regime between two superconducting quantum processors over an about 10 m distance. WMI also operates a helium liquifier with an annual capacity of above 180.000 liters and supplies both Munich universities with liquid helium. To optimize the transfer of liquid helium into transport containers, WMI has developed a pumping system for liquid helium which has been commercialized in collaboration with a company.

To a large extent, the research activities of WMI are integrated into national and international research projects such as Clusters of Excellence, Collaborative Research Centers, Research Units, and projects funded by the Federal Ministry of Education and Research (BMBF) as well as the European Union. Moreover, the individual research groups of WMI offer a wide range of attractive research opportunities for bachelor's and master's students, Ph.D. students, and postdoctoral fellows.

Experimental Facilities and Resources

The WMI is equipped with state of the art facilities for the preparation and characterization of superconducting and magnetic materials as well as for various low and ultra-low temperature experiments. The main experimental and technological resources of WMI include infrastructure for **Materials Preparation and Fabrication of Nanostructures** (such as a UHV-cluster cluster deposition system, a UHV electron beam evaporation and sputtering system for qubit fabrication, several sputter deposition systems for superconducting and magnetic heterostructures, a 100 kV electron-beam system as well as optical lithography tools and tools for 3D integration), for **material and system characterization** (e. g. an x-ray diffractometer, a scanning electron microscope, a AFM/STM system, a SQUID magnetometer, several vector network analyzers, and a wafer-prober) and for operating and characterizing systems at low temperatures (several $^3\text{He}/^4\text{He}$ dilution refrigerators equipped with control electronics). More details can be found on the WMI webpage ([www.wmi.badw.de/research/Materials, Methods and Infrastructure](http://www.wmi.badw.de/research/Materials,MethodsandInfrastructure)).

Building Projects & New Infrastructure



Modular Office Building

A. Marx, M. Opel, S. Filipp

The change of the governance structure of WMI from a single director to a board of three directors was accompanied by a substantial increase in research projects, specifically activities on superconducting quantum computing within the Munich Quantum Valley (MQV) and various BMBF projects entailing a considerably increased need for both lab and office space for new staff members. WMI has decided to deploy modular office containers funded by the MQV beside the WMI main building to accommodate the increase in staff. Planning and tendering were carried out by WMI in collaboration with NOVA Architekten. The contract was awarded to Kleusberg company already in 2023. The construction of the foundation and the provision of all media was the responsibility of the Staatliches Bauamt München II. Network supplies will be provided by the LRZ. Due to delays in the approval process, construction of the foundation, and provision of media, it was not possible to start setting up the containers until the end of August, which means a delay of 8 months. Now that the containers have recently been handed over to the WMI, the furniture can be brought in and regular operations can begin soon. The containers come in a modern modular design with air conditioning and complete infrastructure for a scheduled lifetime of 5 years. The two-floor building, with a usable area of around 300 m², will provide office space for up to 28 staff members in 9 offices, three meeting rooms, a kitchen unit, and a mid-size seminar room hosting up to 24 staff members (c.s. blueprint in WMI Annual Report 2023, page 14).



Collaboration with the Semiconductor Laboratory of the Max Planck Society

S. Filipp

The Semiconductor Laboratory of the Max Planck Society (HLL), the Technical University of Munich (TUM) and the Walther-Meißner-Institute (WMI) of the Bavarian Academy of Sciences and Humanities (BAdW) have agreed on a pioneering cooperation for the joint development of superconducting qubits and quantum processors based on them. The collaboration, which was established as part of Munich Quantum Valley (MQV), marks a significant step in the research and further development of quantum technologies. The partnership aims to develop superconducting qubits as key components for future quantum computers. The HLL's state-of-the-art clean room, which was opened at the same time, provides an ideal environment for this and will enable the production of qubits of the highest quality at the highest international level in the future. The development of advanced integration technology not only forms the basis for the realization of scalable quantum computer systems, it also has the potential to revolutionize a wide range of scientific disciplines, from materials research to high-energy physics.

With the combined expertise of the three research institutions, this collaboration will take the development of quantum computers to a new level. The Max Planck Society's Semiconductor Laboratory will contribute its outstanding expertise in the development of sensors and advanced semiconductor technologies. The Technical University of Munich is contributing its expertise in the characterization and control of quantum systems at the Chair of Technical Physics, while the Walther-Meißner-Institute is contributing its know-how in the fabrication of superconducting components. As a contribution to this cooperation, the semiconductor laboratory is providing parts of its ultra-modern clean room infrastructure, which is essential for the production and processing of the sensitive superconducting circuits. The Walther-Meißner-Institute and the Technical University of Munich are supplementing the infrastructure with state-of-the-art coating and lithography equipment for joint use.

Dr. Jelena Ninkovic, Head of the Semiconductor Laboratory of the Max Planck Society, emphasizes the importance of the collaboration: "The development of superconducting qubits represents a decisive step towards practical applications of quantum computers. Through this partnership, we are not only pooling our expertise, but also creating a unique platform for innovative research and technological breakthroughs." Prof. Dr. Caldwell, Managing Director of the Semiconductor Laboratory, also underlines the importance of the cooperation: "With this col-



Figure 1: The new building of the Max Planck Society's semiconductor laboratory in Garching: state-of-the-art infrastructure for research and development in the field of semiconductor technology.



Figure 2: The new clean room of the Max Planck Society's semiconductor laboratory: expanded capacity for advanced research in nano- and quantum technology.

laboration, we are relying on the synergies between the outstanding research fields of our partners and the expertise of our laboratory. Together we will set new standards in quantum technology.”

With the new possibilities for producing the world’s best qubits that have been created, we can significantly expand the limits of quantum technology. We are thus laying the foundations for the continued success of Munich Quantum Valley in the field of quantum hardware and can sustainably consolidate and further expand our expertise in the independent construction of quantum computers. This cooperation enables us to research fundamental questions of quantum physics. The collaboration offers us a unique opportunity to actively shape the future of quantum computing technology in Germany and Europe.

The collaboration between the Semiconductor Laboratory, TU Munich and the Walther-Meißner-Institute will decisively advance the development of quantum computers in Germany and play a key role in international research efforts. The first joint projects and experiments are already being planned and the results are eagerly awaited.

High-Density Wiring Upgrade for Two Bluefors XLD1000 Systems to Support Mid- to Large-Scale Quantum Processors

*C.M.F. Schneider, N.J. Glaser, F. Wallner, J. Schirk, G.B.P. Huber, J.H. Romeiro, S. Schöbe, I. Tsitsilin, J. Feigl, J. Englhardt, N. Bruckmoser, V. Bader, M. Werninghaus, S. Filipp*¹

WMI has upgraded the wiring infrastructure of two Bluefors XLD1000 cryostats to support mid- to large-scale quantum processing units. The upgrades incorporate Bluefors' High-Density (HD) wiring technology, adding 336 and 120 coaxial lines to the respective cryostats.

The first XLD1000 cryostat is meant to host a 100-qubit quantum processor under the MUNIQC-SC project. With the addition of 336 high-frequency lines, the system now features a total of 400 lines as shown in Fig.1, including 20 superconducting lines dedicated to high-fidelity qubit readout. The second XLD1000 cryostat, aligned with the MQV project, can accommodate two 24-qubit alternative qubit demonstrators. It has been upgraded with 120 high-frequency lines, increasing the total wiring capacity to 328 lines for this setup.

All coaxial lines are thermalized at each cryogenic stage using a combination of attenuators and RF bulkhead feedthroughs, ensuring minimal thermal links while preserving signal integrity across the 4 K, 1 K, and milliKelvin temperature stages. The side-loading infrastructure of the HD Wiring is adapted to the XLD side-loader system, allowing for efficient maintenance, with wiring modules prepared on a workbench and easily exchanged when the system reaches room temperature, reducing downtime. Each system is outfitted with hermetic feedthroughs capable of supporting up to 168 lines per side-loading port, enabling seamless scalability for future upgrades. The installed HD wiring is optimized for signals spanning DC to 18 GHz, with attenuator configurations tailored for each coaxial line based on their specific roles, such as microwave drive signals or flux biasing.

This upgrade significantly enhances WMI's capacity to facilitate cutting-edge quantum processors with increasing number of qubits.

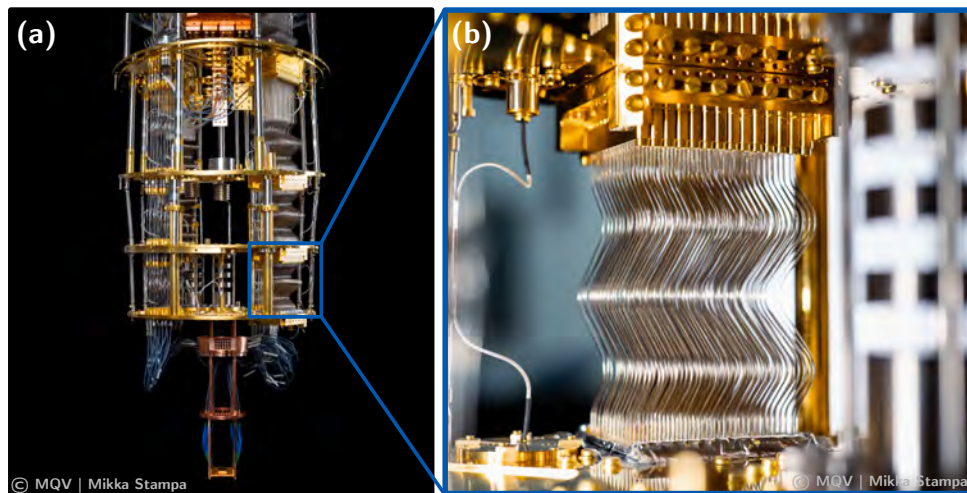

Figure 1: Bluefors XLD1000 system equipped with 400 coaxial lines to support a 100-qubit quantum processor. (a) The complete cryostat without thermal shields is shown, with a quantum chip mounted on a PCB at the bottom and the high-density wiring positioned on the left and right sides of the cryostat. (b) A close-up view of the newly installed high-density wiring highlights the carefully designed bends, which accommodate thermal contractions at cryogenic temperatures.

¹This project is part of the Munich Quantum Valley, which is supported by the Bavarian state government with funds from the Hightech Agenda Bayern Plus and has received support by the Munich Quantum Valley Quantum Computer Demonstrators - Superconducting Qubits (MUNIQC-SC; project number: 13N16188).

Fast-Cycling Cryostats for Rapid Prototyping and Characterizations

K. Kiener, C.M.F Schneider, N. Bruckmoser, J. Schirk, F. Wallner, I. Tsitsilin, J. Feigl, S. Schöbe, V. Bader, S. Filipp¹

In 2024 WMI has expanded its infrastructure with two *Qinu L Pro* table-top dilution cryostats. These systems offer extremely fast turnaround times due to their minimized thermal mass, reaching base temperatures below 15 mK with cooldown times of approximately six hours. Helium-assisted warm-up further reduces the warm-up time to about two hours, enabling rapid cycling and prototyping. The cryostats are designed for ease of use and single-operator handling. Their lightweight and compact shielding system allows the units to be fully opened or closed in just 15 minutes – a considerable improvement compared to conventional dilution refrigerators. Additionally, the flipped design positions the millikelvin stage on top, simplifying sample mounting and enhancing user convenience.

Each Qinu system is equipped with 28 coaxial microwave lines, including four superconducting readout lines with low-noise amplifiers. One system is additionally equipped with feedthroughs for six optical fibers, enabling hybrid optical-microwave experiments. Figure 1 shows the installed fiber optics alongside samples mounted on the millikelvin stage. The millikelvin stage with a diameter of 164 mm provides sufficient space to accommodate multiple experiments and chips simultaneously.

The fast-cycling capability of the cryostat enables accelerated prototyping to advance fabrication processes, supporting the rapid testing of new Josephson junction processes, kinetic inductance materials, new surface cleaning treatments and passivations, among other applications. Optical access to the millikelvin stage facilitates the characterization of optical components at cryogenic temperatures, such as photodiodes. This includes temperature-dependent studies of photodiodes and fiber coupling through repeated warm-up and cooldown cycles, as well as thermal heatload experiments at base temperatures.

One system is additionally equipped with six superconducting cables between the 4K stage and the millikelvin stage, featuring no attenuation or amplifiers, making them suitable for broadband filter characterization. Additionally, both systems feature 48 twisted-pair wires, enabling DC measurements across a wide temperature range, including during cooldown, warm-up, and at base temperature, supporting comprehensive characterizations.

The two new cryostats significantly enhance WMI's innovation capacity, enabling rapid prototyping and sensitive characterization of both DC and microwave cryogenic components.

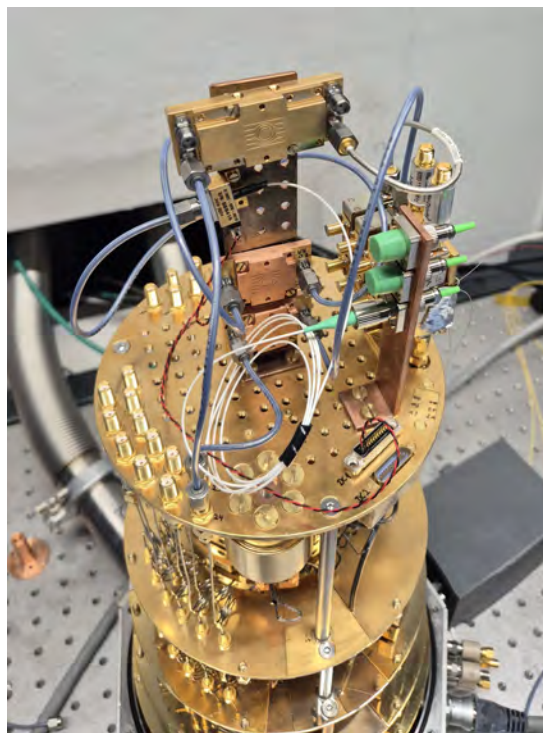
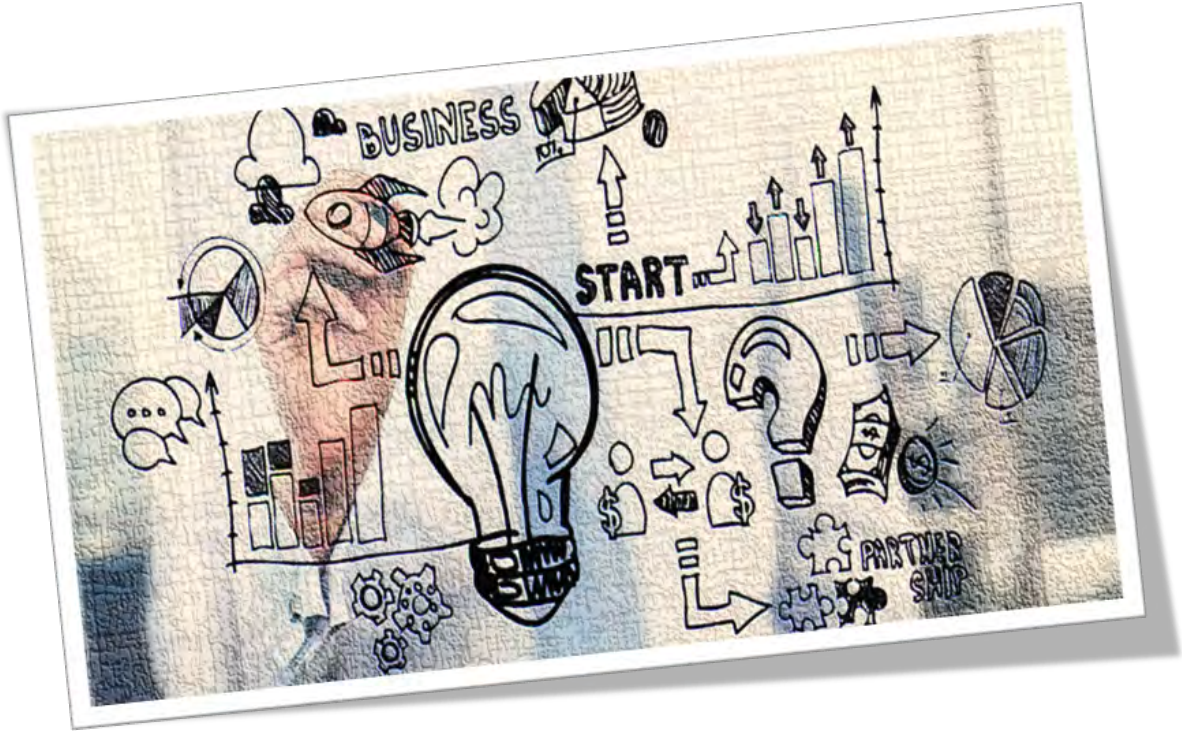

Figure 1: View of an open cryostat with the optical fibers installed. Two samples are mounted and connected to the coaxial and DC lines.

¹The equipment was funded by the German Federal Ministry of Education and Research via the funding program quantum technologies under contract number 13N16188 "MUNIQ-SC" as well as by the BMBF program No 13N15 982 (SEQT).

Entrepreneurship



WMI Announces New Spin-Off Company: Peak Quantum GmbH

T. Luschmann, L. Koch, M. Werninghaus, I. Tsitsilin, K. E. Honasoge, D. Bazulin, A. Schult

In a significant milestone for the Walther-Meißner-Institute, it announced the formation of its first quantum technology spin-off company, Peak Quantum GmbH. This development highlights the WMI's commitment not solely to fostering innovation and world-class research but also to translate these achievements into impactful technologies for society.

Peak Quantum was founded in August 2024 by a group of former and current PhD students from the WMI: Leon Koch, Max Werninghaus, Ivan Tsitsilin, Thomas Luschmann, Kedar Honasoge, and Daniil Bazulin. The spin-off emerges from the pioneering work of Prof. Filipp's quantum computing group, leveraging the institute's breakthroughs in high-quality quantum processors based on superconducting circuits. The company's primary goal is the commercialization of these processors to supply researchers and industrial users worldwide and accelerate scientific advancements in the field of quantum computing.

The long-term vision of Peak Quantum focuses on developing advanced quantum processing unit (QPU) architectures that offer superior error protection and scalability. These efforts aim to address critical challenges faced by the international quantum computing community on the way towards fully error-corrected and application-ready quantum computing systems.

Since the spin-off efforts gained traction in late 2023, the founding team has benefited from Munich's vibrant entrepreneurial ecosystem, particularly through UnternehmerTUM, one of Europe's leading entrepreneurship centers, and the Venture Lab Quantum (VLQ), which was established as part of the Munich Quantum Valley (MQV) Initiative. Participation in UnternehmerTUM and VLQ programs and networks enabled the team of WMI scientists to recruit an experienced business and finance professional, Alexander Schult, strengthening their capabilities in establishing and scaling the company. The efforts culminated late this year in securing financial backing through the EXIST Technology Transfer grant provided by the German Federal Ministry for Economic Affairs and Climate Action (BMWK). This grant facilitated the transition of the first founders to full-time roles, leading to the formal incorporation of Peak Quantum GmbH.

The establishment of Peak Quantum is a testament to the strong support and encouragement provided by the WMI, the BAdW, and the Technical University of Munich. These institutions have actively promoted entrepreneurial initiatives and continue to support Peak Quantum's development by granting access to the WMI's advanced laboratory infrastructure. This collaborative framework ensures that the spin-off retains a strong connection to its academic roots while driving impactful technological developments in the private sector.

Looking ahead, WMI and Peak Quantum are committed to fostering close collaborations on future research projects. By combining the resources and expertise of public research institutions with the agility and market focus of a private company, this partnership aims to drive scientific and technological progress that can address both academic and industrial needs.

Peak Quantum Jumpstarting your quantum journey



Figure 1: Peak Quantum's Logo and a photograph of its first pilot product: A commercially available single-qubit benchmarking device for use in quantum computing research laboratories.

Joint Research Projects

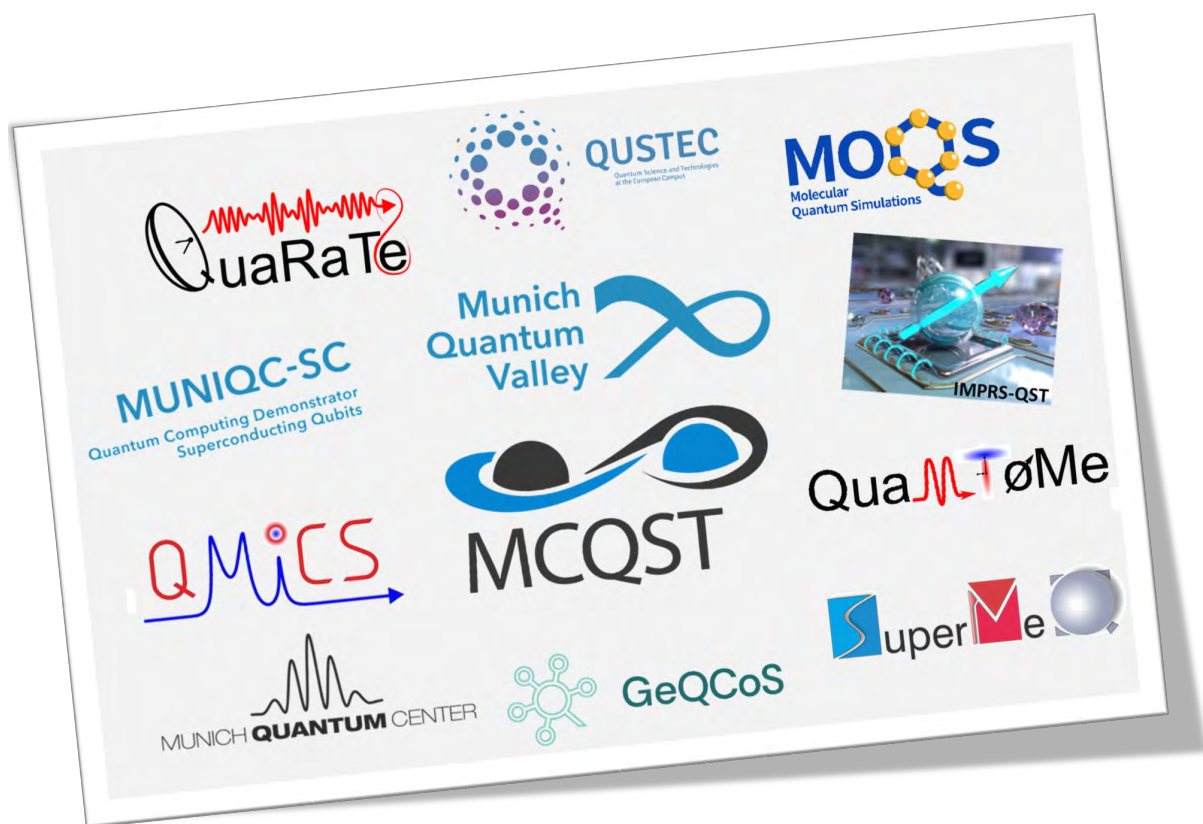

Munich Center for Quantum Science and Technology – an Ongoing Success Story in Quantum Science

Rudolf Gross, Peter Rabl ¹

Ever since the Walther-Meißner-Institute (WMI) was founded in 1946, quantum physics has played a central role in the research topics dealt with at WMI. From the very beginning, WMI has been working on quantum materials (superconductivity & magnetism) and has shaped the field of quantum science with pioneering experiments, e.g., on flux quantization (1961), the intrinsic Josephson effect (1992), ultra-strong light-matter interaction (2010), quantum communication in the microwave range (since 2010), and strong magnon-photon coupling (2013). WMI also made major contributions to enabling technologies such as the development of dry dilution refrigerators (2002), and today WMI plays a central role in the development of basic technologies for superconducting quantum computers. We are therefore looking forward with excitement to the coming year 2025, which has been declared the **International Year of Quantum Science and Technology** by the United Nations.



In the field of quantum science and technology (QST) focusing on solid-state quantum systems, WMI has played a key role within the past 25 years and has provided key contributions to the development of the highly successful Munich quantum ecosystem. This started already with the CRC 631 on **Solid-State Quantum Information Processing** (2003-2015), continued with the quantum research within the Cluster of Excellence **Nanosystems Initiative Munich (NIM)** (2006-2018) and several graduate schools, and finally led to the foundation of the Cluster of Excellence **Munich Center for Quantum Science and Technology (MCQST)** in 2019. Meanwhile, the first funding period has already come to an end, and it is clearly evident that MCQST is prospering and has developed into a highly successful enterprise. Without any doubt, MCQST is the cornerstone of a broad variety of quantum-related research activities in Munich and all over Bavaria. It is quite likely that without the pioneering work of the MCQST scientists, subsequent projects such as the Munich Quantum Valley (MQV) would not have been possible. MCQST also plays an important role in the long-term research strategy of WMI. Together with the CRC 631, MCQST has been the basis of WMI's ambitious research program and provided the preliminary work for a large number of follow-up projects funded by BMBF, EU, and the Free State of Bavaria.

About the Munich Center for Quantum Science and Technology

The cluster of excellence **Munich Center for Quantum Science and Technology (MCQST)** step by step is advancing toward the originally envisioned world-leading center in quantum science and technology. All major Munich research institutions being active in fundamental research are involved in MCQST: LMU München, TUM, Max Planck Institute of Quantum Optics (MPQ), Walther-Meißner-Institute (WMI), as well as Deutsches Museum (DM), which serves as an outreach partner (see Fig. 1). Meanwhile, MCQST plays a pivotal role in quantum science not only in the Munich area but also on an international scale. MCQST is a highly interdisciplinary endeavor. It comprises seven research units within disciplines such as physics, mathematics, computer science, electrical engineering, material science, and



¹The Munich Center for Quantum Science and Technology is supported by the German Research Foundation via Germany's Excellence Strategy (EXC2111-390814868).

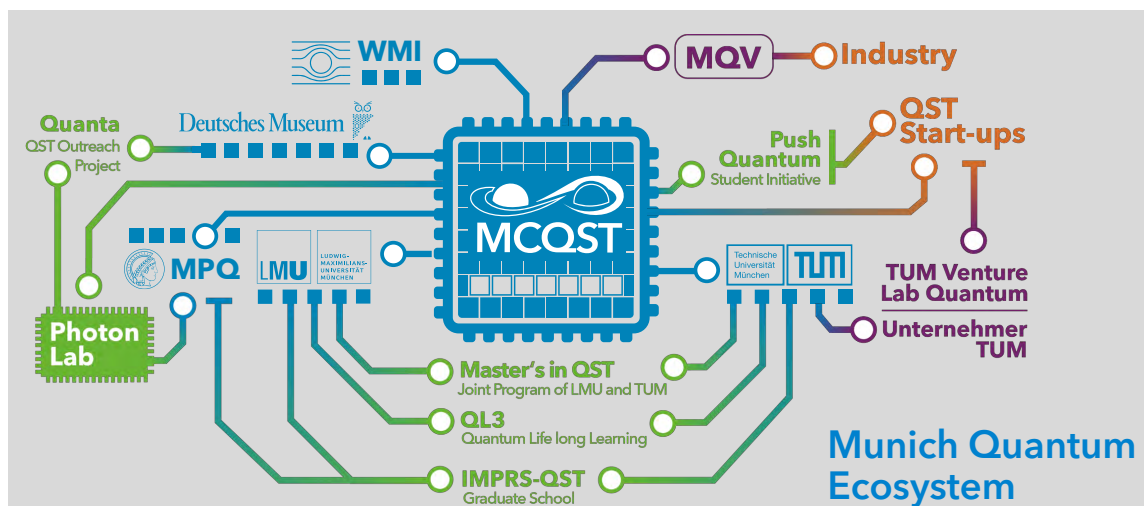

Figure 1: The Munich Quantum Ecosystem: founding institutions (blue), partners (orange and violet) and programs (green).

chemistry, covering all areas of Quantum Science and Technology (QST). Its main goal is to build a world-leading center in QST, with a multi-disciplinary profile, addressing important scientific and technological questions. It links groundbreaking research with industrial partners, creating a unique environment for QST via carefully designed structural measures that will transform the existing scientific and technological environment.

Opening of the Light & Matter Exhibition at Deutsches Museum

One of the main objectives of MCQST's outreach activities was to establish a permanent exhibition on quantum phenomena at the Deutsches Museum, to make the broader public aware of QST and its impact on society. Therefore, already in 2029 the MCQST outreach partner Deutsches Museum established an Advisory Board responsible for planning the content of the exhibition and supporting Johannes-Geert Hagman and his team from Deutsches Museum, responsible for implementing the exhibition. MCQST spokesperson Rudolf Gross became a member of the advisory board together with Ted Hänsch (MPQ), Wolfgang Ketterle (MIT), Markus Greiner (Harvard University), and Christian Joas (Niels-Bohr-Archive Copenhagen). After 5 years of hard but also enjoyable work, we were excited that the **Light & Matter Exhibition** could be opened on 18 June 2024. The opening ceremony (see Fig. 2) included a welcome address and popular science talk by Wolfgang Ketterle, opening remarks by state minister Markus Blume, and a panel discussion on the Future of Quantum Technologies. Ralph Caspers, well-known from the "Sendung mit der Maus", led through the program.

Since the start of the 20th century, scientists have discovered new phenomena related to the interaction between light and matter. Many of these phenomena challenge our intuition and can be understood only through the principles of quantum physics. Now the **Light & Matter Exhibition** offers a fascinating overview of quantum optics and shows non-experts how our understanding of light and matter has evolved over the past century. It also provides an introduction to the cutting-edge world of quantum sciences and technologies, which are currently in the focus of intense research.

Already today we can say that the **Light & Matter Exhibition** at the Deutsches Museum is one of the highlights of MCQST's outreach activities. It features over 80 exhibits, including Nobel Prize-winning discoveries, and more than 20 interactive stations, making complex physical phenomena accessible to visitors. Importantly for MCQST, visitors have the opportunity to engage with state-of-the-art research ongoing within MCQST through continuously changing exhibits and interactive stations. The exhibition is located at the main entrance of the



Figure 2: Some impression from the opening ceremony of the Light & Matter Exhibition on 18 June 2024 (photos: Hohmann/MCQST).

Deutsches Museum, which is frequented by about 3,000 visitors on average every day, spanning virtually all age groups and educational levels. Due to the large number of visitors with different interests and backgrounds, we are confident that the exhibition will be a big success and lead to exceptional visibility and impact.

MCQST Submitted Proposal for Next Funding Period



Figure 3: The cover page of the MCQST-2 funding proposal submitted in August 2024.

As the first funding period of MCQST already ends in December 2025, the funding proposal for the next 7-year period, including the report on results achieved so far, had to be prepared in 2024. After a Letter of Intent was submitted to DFG early in 2024, stating that MCQST would submit a continuation proposal, the full proposal was submitted in August 2024. The review of the funding proposal by a panel of international experts took place on 27 November 2024 in Bonn. Due to the highly competitive nature of the excellence strategy the presentation of MCQST-2 at the review meeting has been prepared very carefully in several rehearsal sessions. The entire process was led by the designated spokespersons Immanuel Bloch (LMU/MPQ), Ignacio Cirac (MPQ/TUM), and Barbara Kraus (TUM), who will take over the role as the TUM spokesperson from Rudolf Gross in the next funding period. Peter Rabl, as part of the writing team, and Rudolf Gross, as the spokesperson of MCQST-1 and a critical internal reviewer, represented the WMI throughout all stages of this application.

Unfortunately, the decision of the evaluation commit-

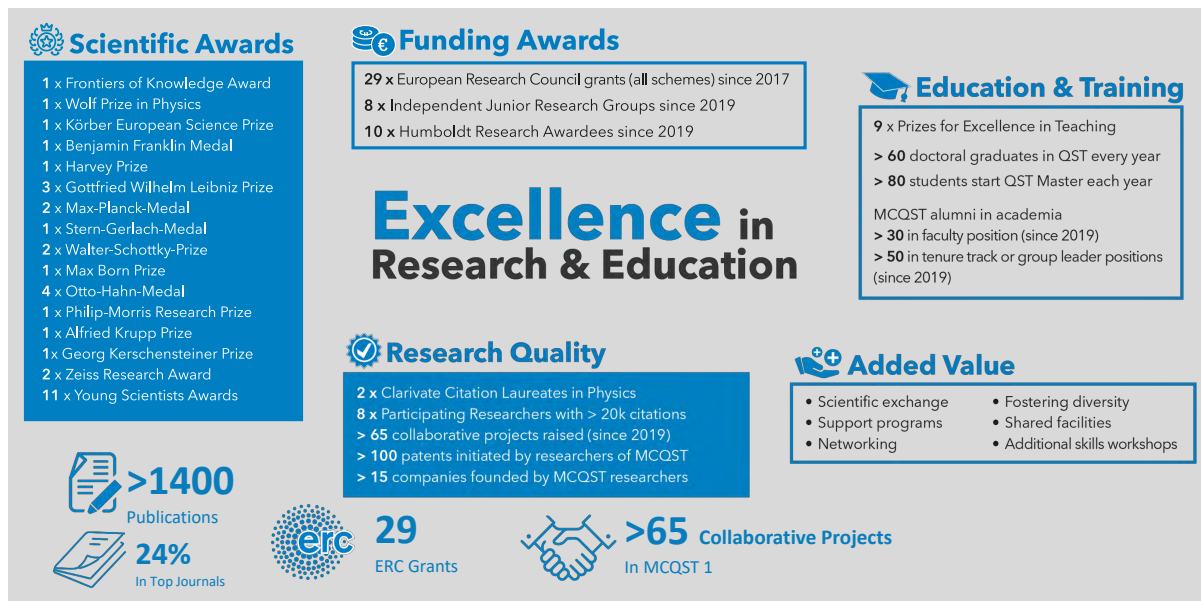

Figure 4: Key achievements of MCQST within the first funding period (2019-2025).

tee will not be available until spring 2025. However, the achievements of MCQST-1 are outstanding not only regarding scientific results but also in the fields of outreach, quantum education, structural measures, and support of young scientists (see Fig. 4). The success of MCQST is also documented by its high international visibility. Therefore, there is good reason to be optimistic about the outcome of the final decision-making process. It would be a shame if this excellent research program could not be continued.

If funded, MCQST-2 will place an even stronger emphasis on education, collaboration, and internationalization, thereby benefiting the entire quantum science community in Munich and further fostering the quantum ecosystem. Regarding the key research directions, the focus will remain on curiosity-driven basic research, covering topics ranging from quantum simulation and quantum networks to novel quantum sensing schemes in hybrid and many-body quantum systems. The only major change will be in the field of quantum computing. Since this topic is broadly covered by MQV, quantum computing will no longer be a core research field of MCQST and future research activities will concentrate only on overarching and basic aspects.

The WMI will be represented in MCQST-2 by Kirill Fedorov, Hans Hübl, Nadezhda Kukharchyk, Stefan Filipp, Rudolf Gross, and Peter Rabl. As in the first funding phase, WMI will continue to be a key contributor to and beneficiary of the MCQST.

MCQST Events

Within the past year, MCQST was organizing a large number of conferences, workshops, colloquia, schools, and other programs with many contributions from WMI scientists. For a list of those events, we refer the reader to the [MCQST web page](#). Information on important discoveries, highlights, outreach activities, awards, press releases etc. can be found on the [news section](#).

Successful Starting Phase of Munich Quantum Valley

Rudolf Gross ¹

The **Munich Quantum Valley (MQV)** started in October 2021 as one of the flagship projects of the **Hightech Agenda Bavaria**. A comparable R&D project of similar complexity as MQV did exist before in Bavaria. Therefore, from the beginning MQV to some extent also was an experiment with an uncertain outcome. We are all the more pleased that we have come through the difficult start-up phase very well. **Rudolf Gross** of WMI was taking over the position of the MQV Scientific Director from **Rainer Blatt** in August 2023 (see [press release from 01 August 2023](#)). He then was responsible for preparing both the **MQV Public Report 2023**, informing the broader public on the MQV key achievements and activities, and a confidential **Internal Report** as the basis for an intermediate review. The review process, taking place from 29 February to 1 March 2024, was going very well and resulted in a very positive report from the International Review Committee. The international experts confirmed that MQV has started up very well and is on the right track for the future. They recommended to release the budget for the rest of the first funding period. They also supported several suggestions for improvements regarding project steering, flexibility in the usage of funds, and governance structure made by the MQV management to increase flexibility in decision-making processes and to allow for a flexible adjustment of project parts to new developments.



Based on the positive intermediate evaluation as well as the encouraging progress and broad experience gained within the first three project years, MQV can now plan the next stage of development with a great deal of self-confidence. As the next step, a strategy paper for the next funding phase starting in January 2027 has to be prepared by spring 2025. The main goals of this strategy paper will be (i) to define the main research directions, (ii) to fix a clear roadmap for the technical developments, (iii) to propose a more flexible governance and adapted legal structure, and (iv) to lay out the financial framework conditions for the next funding phase.

In mid-2024, Rudolf Gross, who planned to take over the overall responsibility for MQV only for an intermediate period of time from the beginning, handed over the baton to **Joachim Ullrich**, the new MQV Director General, but still continued to support MQV as its Managing Director. Together with Rainer Blatt and the MQV Office, he also performed regular internal reviews in the form of so-called site visits. This internal review process turned out to be very important in identifying weak project parts early, getting a comprehensive overview of the complex MQV project, and stimulating interactions between the different MQV consortia.



Figure 1: Prof. Dr. Joachim Ullrich, MQV Director General (photo: MQV).

¹Munich Quantum Valley is supported by the Bavarian state government with funds from the Hightech Agenda Bavaria.

About the Munich Quantum Valley

MQV is organized as a registered association and combines the research capacities and technology transfer power of three major universities (TUM, LMU, FAU) and key research organizations (BAAdW, MPG, FhG, DLR) in Bavaria in an unprecedented intensity of cooperation. As a collaborative project between academia, industry, research, and public organizations, MQV offers state-of-the-art framework conditions for the emergence and further research of quantum technologies and quantum computing throughout Bavaria and forms a crucial part of the Bavarian quantum technology ecosystem. Meanwhile, MQV has established a rapidly growing **Partner Network**, bringing together stakeholders from research institutions, universities, and companies whose common goal is to promote quantum science and quantum technologies in Bavaria.

MQV is a key part of the **Hightech Agenda Bavaria**, used by Bavaria to rigorously invest in state-of-the-art research and career prospects with regards to innovative future technologies. With an investment of approximately 5.5 billion euros, the Hightech Agenda Bavaria is one-of-a-kind in Germany. The initiative invests in the brightest minds and aims to create and maintain 3,800 positions across Bavarian universities. Among these positions, 1,000 new professorships will be established in key future fields such as artificial intelligence, quantum technology, clean tech, and aerospace.



With the Walther-Meißner-Institute (WMI) and the Leibniz Supercomputing Centre (LRZ) the Bavarian Academy of Sciences and Humanities (BAAdW) is one of the key players of MQV. At WMI, the groups of all three Scientific Directors are strongly involved in the R&D program of MQV.

MQV Vision and Mission

Building a Quantum Future – to implement this vision, MQV promotes quantum science and quantum technologies in Bavaria with the primary goal of developing and operating competitive quantum computers. It connects research, industry, funders, and the public by promoting an efficient knowledge transfer from research to industry, establishing a network with international reach, and providing educational offers for schools, universities, and companies.

The **Quantum Mission** of MQV includes to following key parts:

A. Creating a powerful quantum ecosystem in Bavaria

As a hub between research, industry, funding agencies, and the public, MQV establishes a powerful quantum ecosystem in Bavaria to promote efficient knowledge transfer between academia and industry and operates an internationally leading center for developing the full spectrum of quantum technologies. MQV explores novel concepts in QST in focused lighthouse projects, operates a world-class research high-tech infrastructure, offers tailored educational programs for schools, universities, and companies, a platform for international networking, and targeted entrepreneurial support for start-ups.

B. Developing quantum computing and technologies for real-life applications

Using innovatively engineered superconducting, neutral-atom, and trapped-ion platforms, the overarching mission of MQV is to realize full-stack quantum-computer demonstrators, remotely accessible to researchers and industry through seamless integration with local high-performance computing infrastructure. By jointly developing hardware and software, MQV will provide the quantum computing tools allowing to address challenging real-life problems. On a medium-term basis (5–10 years), MQV will focus on noisy intermediate-scale quantum

computers with up to 1000 qubits, while the long-term goal is to develop fault-tolerant quantum computers capable of solving practical problems relevant to the economy and society. Besides an ambitious focus on quantum computing, MQV will create innovation in many related technology fields.

C. Building on unique Bavarian strengths

MQV builds on its founding members' longstanding tradition and outstanding excellence, covering all fields of QST, and an exceptional industrial high-tech environment. By coordinating efforts of academia, industry, and funding agencies, MQV provides a unique ecosystem, enabling efficient knowledge transfer between research and industry and establishing a network of high international visibility. MQV provides the tools and services to drive the commercialization of quantum technologies and to catalyze their transition from theoretical concepts to tangible real-world applications.

MQV Roadmap

Quantum technologies are expected to be era-defining, similar to digital technologies shaping the information age. Therefore, the development of quantum technologies will extend over a longer period and most likely will also be accompanied by technology disruptions. Therefore, the MQV roadmap shown in Fig. 2 has been planned for an intermediate to long time scale from the beginning. It is expected that MQV will play a leading role in the long-term development of quantum technologies and enable Bavaria to take a leading role in the industrialization of this important future technology. The world-leading know-how built up and concentrated within MQV will provide industry and start-ups a competitive advantage by having immediate access to this know-how. Moreover, the vibrant MQV quantum ecosystem is expected to be a decisive factor for Bavaria's competitiveness in attracting quantum industry and start-ups, as well as fostering investments.

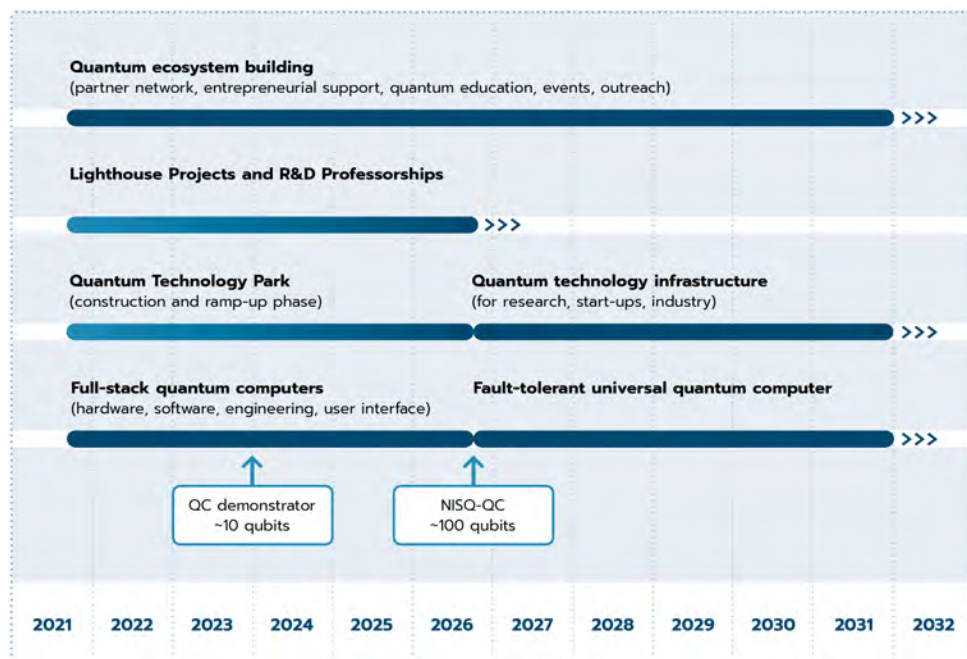

Figure 2: The MQV Roadmap with the key program components. Important milestones regarding the development of full-stack quantum computers in the first program phase (2021–2026) are a quantum computer demonstrator with about ten qubits and a Noisy Intermediate-Scale Quantum Computer with about 100 qubits.

Within the first funding period (October 2021 to December 2026), MQV aims to

- develop full-stack quantum computers based on different hardware platforms,

- realize high-tech infrastructures and enabling technologies for quantum research within an open-access Quantum Technology Park and provide tailored entrepreneurial support for quantum technology start-ups within the **Quantum Technology Park & Entrepreneurship (QTPE)** consortium,
- develop targeted programs for educating the next generation of quantum scientists and engineers within its **Quantum Science and Technology Education in Bavaria (QST-EB)** consortium,
- explore novel concepts and quantum-enabling technologies in focused **Lighthouse Projects** and
- strengthen quantum science at universities by additional **MQV professorships**.

WMI makes important contributions to the implementation of this ambitious program (see reports on pages 33, 69, 71, 73, 75, 81, and 87). In particular, WMI (i) coordinates the **Superconducting Qubit Quantum Computer (SQQC)** consortium of MQV, developing the hardware for superconducting quantum computers, (ii) coordinates the **Quantum Technology Park & Entrepreneurship (QTPE)** consortium which aims at realizing an open-access Quantum Technology Park and providing tailored entrepreneurial support for quantum technology start-ups, (iii) hosts one of the MQV professors (Pater Rabl), and (iv) is a key partner in the two **Lighthouse Projects** NeQuS and IQSense.

MQV Events

Engaging with the public by communicating the fascination of quantum science and technology and moderating the discussion about expectations, hopes, and possible fears is an important task of MQV. The same is true regarding stimulating interactions between the scientific community, industry, start-ups, and users. Therefore, MQV organized and participated in various events in 2024 and further developed its own outreach formats and educational offers. WMI made major contributions to these events. Some of them are listed in the following (a complete list can be found [here](#)):

- **Quantum Sensing: nanotechnology, patenting, commercialization**, 6 – 7 March 2024, Studio G3, Munich.
- **BAdW Symposium - Quantum Technologies. Expectations of an important future technology**, 12 April 2024, Munich Residence.
- **Hannover Messe 2024**, 21 – 26 April 2024, Hannover.
- **A Day as a Microtechnologist: MQV Girls' Day**, 30 April 2024, EMFT, Munich.
- **MQV Supplier Workshop**, 19 June 2024, IAS Garching.
- **FORSCHA 2024**, 28 – 30 June 2024, Munich.
- **Festival on the Museum Island**, 29 – 30 June 2024, Deutsches Museum, Munich.
- **MQV at the Bavarian Evening of the 73rd Lindau Nobel Laureate Meeting**, 8 July 2024, Lindau.
- **Quantum Effects trade fair and conference 2024**, 8 – 9 October 2024, Messe Stuttgart.
- **2024 MQV Annual Meeting**, 8 – 10 October 2024, Eichstätt.
- **2024 Munich Quantum Software Forum**, 24 – 25 October 2024, Galileo, Garching.
- **MQV Symposium: Towards Applications of Quantum Computing**, 11 – 12 November 2024, BAdW.
- **MQV at the Electronica 2024**, 12 – 15 November 2024, Munich.
- **Future of Computing Conference 2024**, 11 December 2024, Munich Urban Colab.

A 17-Qubit Quantum Computing Demonstrator built within the projects GeQCoS, MUNIQC-SC and MQV

*K. Liegener, M. Werninghaus, S. Filipp*¹

The Walther-Meißner-Institute (WMI) is actively engaged in several projects exploring the viability and scalability of future quantum computers based on superconducting qubits. It is playing a major role in Germany's pursuit to become a major player in quantum computing and quantum technologies. Over the past year, WMI has more than doubled its qubit count. By the end of 2024, it has successfully cooled down and characterized a new 17-qubit quantum processing unit, solidifying its position as a leader in Germany's quantum computing hardware efforts. In particular, three closely interconnected projects combined their efforts and made significant progress in the last year.

WMI is advancing quantum computing research within the **"Munich Quantum Valley" (MQV)** initiative, in collaboration with Friedrich-Alexander University (FAU) and the Technical University of Munich (TUM). This initiative focuses on building the infrastructure needed to scale quantum computing technologies. In recent years, MQV has significantly expanded its capacity, enabling the fabrication and hosting of multiple quantum processing units. WMI has made notable advances in nanofabrication, achieving high-coherence superconducting qubits with world-record relaxation times exceeding $400\mu\text{s}$, see page 87. Software scalability has also improved, drastically reducing the time required for characterization and calibration routines and automated the process to a large degree. Additionally, WMI is exploring alternative qubit types, such as fluxonium-type superconducting qubits, demonstrating subharmonic control for added protection against noise (see pages 75, 77) and pioneered hybrid structures at FAU, which combine transmon and fluxonium qubits.

The complementary project **"Munich Quantum Valley Quantum Computer demonstrators – Superconducting Qubits" (MUNIQC-SC)** started in January 2022. The project aims to develop a quantum computing demonstrator with up to 100 superconducting qubits by the end of 2026. This ambitious goal requires addressing significant scalability challenges. In collaboration with Zurich Instruments, WMI optimized multiplexed readout on four qubits, achieving high single qubit fidelity of 99.1%. The efforts of the partners Fraunhofer-Gesellschaft and Infineon have made substantial progress in developing superconducting qubits using industrial-grade fabrication processes. For larger devices it will become important to fabricate the QPUs with 3D integration methods, hence first work on indium bumps (see page 89) and through silicon vias have been conducted. Furthermore, collaboration with the Leibniz Supercomputing Centre enabled remote-access execution of quantum experiments (see page 71).

These efforts are accompanied by the **"German Quantum Computer based on Superconducting Qubits" (GeQCoS)** project, which launched in 2021. GeQCoS explores innovative methods for realizing superconducting qubits and validating their performance through a nine-qubit demonstrator. It has already demonstrated advances in optimal control leading to the realization of 2-qubit gates with high fidelities $> 99.9\%$, a world-class benchmark in quantum computing.

¹We acknowledge the funding received for the GeQCoS and MUNIQC-SC initiatives from the Federal Ministry of Education and Research (BMBWF) under funding numbers 13N15680 and 13N16188 respectively. The research is part of the Munich Quantum Valley, which is supported by the Bavarian state government with funds from the Hightech Agenda Bayern Plus.

The quantum computing division at WMI coordinates these three projects, integrating their individual advancements to achieve a significant milestone this year, the fabrication and characterization of a 17-qubit chip entirely at the WMI facilities. This chip employs transmon qubits arranged in a lattice structure, interconnected by tunable couplers (see Fig. 1). The current device in WMI's laboratories demonstrates median lifetimes of $60.4 \mu\text{s}$ and achieves median single-qubit fidelities of 99.5%. For detailed information, refer to the contribution on page 69.

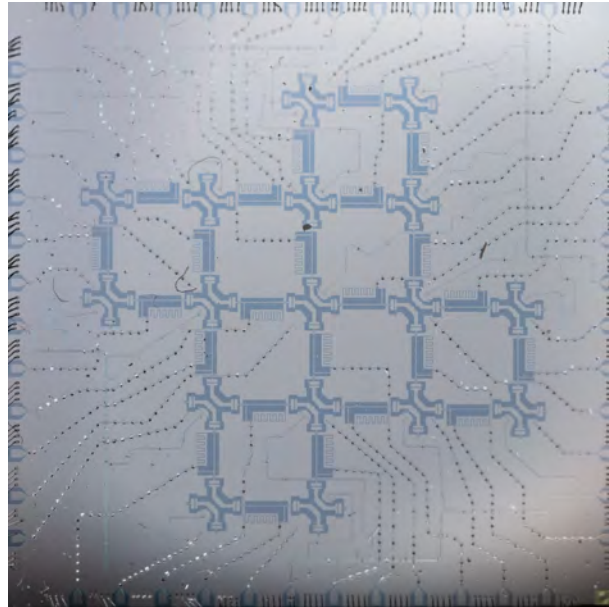

Within these projects WMI strengthens its collaboration with academic and industrial partners. By advancing qubit design, simulation tools, fabrication techniques, and system integration, the projects are laying the groundwork for larger-scale, high-performance quantum processing units in the near future.

Figure 1: A 17-transmon-qubit demonstrator (with 24 tunable couplers) fabricated by WMI.

The BMBF-funded Project QuantumSPICE

*S. Filipp, V. Bader, L. Koch, L. Södergren, M. Werninghaus*¹

Despite the impressive recent advancements in quantum computing, there are still significant challenges to address before its widespread applications can be realized. Aside from the technology hurdle to control a large number of quantum circuits – up to millions – scalability to higher qubit counts with reproducibly high quality factors and the implementation of fast learning cycles for development and commercialization poses a main challenge for the manufacturing of quantum processors. Only by overcoming these challenges can technological sovereignty and access to powerful quantum computers be ensured at both the national and European levels. For this reason, the project ‘Quantum Superconducting Process Innovation with Characterization Enhancement’ (QuantumSPICE) focuses on improving the quality and reliability of so-called Josephson junctions, which form the foundational building blocks of all superconducting quantum computer chips. The exploration of alternative and innovative large-scale characterization methods aims to enable significantly accelerated learning cycles.

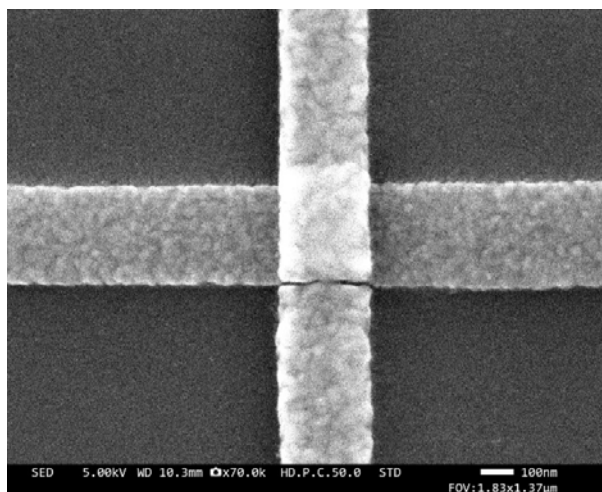

Figure 1: Scanning tunnel microscope image of a Josephson junction fabricated as part of a superconducting qubit at the WMI.

QuantumSPICE has started in November 2024 and runs for 3 years. The project combines the qubit fabrication capabilities of the Walther-Meissner-Institute with the industry-scale process know-how of Infineon, one of Europe’s largest semiconductor manufacturer, and with the expertise of kiutra, a Munich-based startup, on cryogenic measurement systems. The goal of QuantumSPICE is to research and optimize material combinations and processing options used in the fabrication of superconducting quantum circuits. The focus is on enhancing the performance of Josephson junctions, which is the key element of a superconducting quantum circuits formed by a thin oxide layer sandwiched between two superconducting metal electrodes as shown in Fig. 1. The project partners will investigate various material systems for future scalability, integration, and fabrication. Additionally, the consortium will explore innovative solutions for faster characterization at low temperatures to facilitate the required accelerated learning cycles.

Within this project the WMI aims to build on its progress towards high-coherence qubits to realize scalable quantum processors. Through intensive optimization of fabrication processes for superconducting thin films and Josephson junctions, the WMI has by now achieved resonator quality factors of ten million and qubit coherence times of several hundred microseconds (see page 87) positioning the WMI at the forefront of international research and development in this field. In light of the significant further improvements in coherence times required for quantum processors, WMI’s primary responsibilities in this project include the investigating of the impact of material defects, so called two-level systems (TLSs), on qubit coherence times, the analysis and characterization of fabrication processes to minimize defects

¹We acknowledge financial support from the German Federal Ministry of Education and Research via the funding program quantum technologies - from basic research to the market under contract number 13N17044 (QuantumSPICE).

in Josephson junctions for further improvement of qubit coherence and the exploration of 3D structuring concepts to enhance scalability. These tasks represent a natural continuation and complement to the fabrication improvements made in the BMBF-funded projects GeQCoS and MUNIQC-SC projects as well as in the Munich Quantum Valley initiative.

The QuantumSPICE project, with its concept of innovative material research, optimized processing techniques, and component miniaturization combined with efficient characterization, offers a new approach to advancing research on superconducting quantum circuits. It aims to address the urgent need for performance improvements and future scalability of this technology efficiently. This paves the way for the next generation of superconducting quantum computers “Made in Europe”.

Highlights



Research Highlights

In the following, we list a selection of highlight publications of WMI in the year 2024:



23.01.2024: Phonons with spin. The magnetoelastic coupling of magnetic and elastic excitations enables the generation of elastic waves carrying angular momentum. In a quantum picture, this corresponds to a resonant conversion of magnons to chiral phonons and vice versa. WMI researchers realize this conversion process using a simple and versatile experimental platform consisting of a metallic magnetic thin film on a crystalline substrate. These findings allow us to study the impact of crystal symmetry on angular momentum transport by phonons and investigate phononic birefringence.



30.05.2024: Microwave Single-Photon Detectors are within Reach. WMI scientists provide important new insight into transmon ionization (TI). This process is detrimental to superconducting qubit coherence and limits the performance of **microwave single-photon detectors (SPDs)** based on a 3D multimode cavity coupled to a transmon qubit. Based on their detailed study, the WMI researchers can propose potential solutions for further increasing the quantum efficiency of SPDs, which are key elements for for advancing quantum communication and sensing technologies.

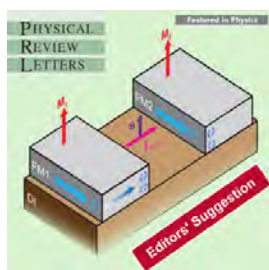

24.06.2024: A New Way to Transport Spin Currents. In a recent Physical Review Letters, a team of researchers from the Walther-Meißner-Institute (WMI) of the Bavarian Academy of Sciences and Humanities (BAAdW), the Technical University of Munich (TUM), the ETH Zürich, the University of Konstanz and the Universidad Autónoma de Madrid (UAM) has demonstrated the transfer of spin information between two separated ferromagnetic metal strips harnessing magnetic excitations, providing a new avenue for spintronics.



30.08.2024: Quantum cryptography goes microwave. Quantum technology allows for unconditional security in microwave-based communication. Now, a team of researchers from the Bavarian Academy of Sciences and Humanities (BAAdW), the Technical University of Munich (TUM), the University of Tokyo, and Rohde & Schwarz GmbH joined forces to demonstrate the successful realization of a quantum key distribution (QKD) protocol in the microwave regime. This significant achievement is highly relevant for modern communication systems.

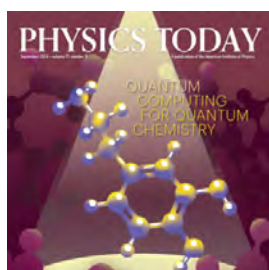

10.09.2024: Cover article in the September issue of Physics Today. As part of the "MOQS – Molecular Quantum Simulations" consortium, researchers at WMI explored the potential of quantum computing to simulate the quantum effects that govern chemical reactions. Their findings suggest that the chemical industry could be

among the earliest beneficiaries of advancements in quantum computing. The report was prominently featured as the cover article in the September issue of *Physics Today* and is available to read online free of charge.



09.10.2024: P-Mon: A noise protected superconducting qubit. In their experiment, researchers at the WMI design and characterize a multimode superconducting quantum circuit that forms an artificial molecule. The circuit has two characteristic nonlinear oscillation modes. One is used as a protected qubit mode that can be efficiently decoupled from the measurement circuit to prevent the loss of quantum information. The second mode is used as a mediator that controls the interaction between the qubit mode and the measurement circuit. This protected multimode qubit has the potential to also suppress unwanted interactions between neighboring qubits, thereby solving another major challenge in scaling up quantum processors. It can thus serve as a building block for a quantum processor architecture that retains the performance of a single qubit at large scale.

Basic Research



Optical setup for Brillouin light scattering.

Semiclassical Simulations of Dissipative Spin Systems

X. H. H. Zhang, A. K. Ardyaneira P., F. Pöschl, P. Rabl¹
D. Malz²

The numerical simulation of quantum many-body systems is a particularly difficult task, due to the exponential increase of the Hilbert-space dimension with larger particle numbers. In the theory division at WMI, we study a semiclassical method, the so-called discrete truncated Wigner approximation (DTWA) (see e.g. [1–3]), and explore its applicability for the simulation of driven-dissipative quantum many-body effects. It turns out that this method, whose computational complexity scales linearly in system size, is very efficient and can capture many interesting physical phenomena that have been inaccessible previously. This includes Dicke superradiance [4, 5] in non-homogeneous systems and non-equilibrium phase transitions in dissipative Heisenberg XYZ models [6].

The Method

One of the most commonly used but very crude approximations in quantum many-body physics is mean-field (MF) theory, which, however, can lead to incorrect predictions when quantum fluctuations become important. DTWA is an approximation that adds certain quantum fluctuations to the MF dynamics, which turns out to work quite well for a wide class of problems with only linear complexity. To illustrate how DTWA works, we can take the spin-up state $|\uparrow\rangle$ of a single spin-1/2 as an example. In the discrete Wigner representation, this state is represented by a classical vector with random components $\{(\pm\frac{1}{2}, \pm\frac{1}{2}, \frac{1}{2})\}$ along the (x, y, z) directions. The averages of the mean spin components as well as their fluctuations then reproduces the correct quantum mechanical values. Similarly, we can write out stochastic ensembles for a many-spin initial state. Under the DTWA, the dynamics of the ensemble still follows MF theory.

Superradiance

Dicke superradiance [4] is a classic example of collective effects of many spins in quantum optics, where the cooperation between spins lead to much faster decay. Since DTWA works the best around the MF regime and superradiant systems have long-range interactions, we use DTWA to explore Dicke superradiance with disorder [Fig. 1 (a)], to see if disorder destroys the collective effects. The system dynamics can be described by a master equation of the form

$$\frac{d}{dt}\rho = -i[H, \rho] + \mathcal{D}[J_R]\rho + \mathcal{D}[J_L]\rho, \quad (1)$$

where $H = \frac{\gamma}{2} \sum_{j,l} \sin(k_0|z_j - z_l|) \sigma_j^+ \sigma_l^-$ is the coherent interaction between qubits mediated by the waveguide and $\mathcal{D}[J]\bullet = J\bullet J^\dagger - \frac{1}{2}\{\bullet, J^\dagger J\}$ are the dissipators with the jump operators $J_{R/L} = i\sqrt{\frac{\gamma}{2}} \sum_j e^{\mp ik_0 z_j} \sigma_j^-$. When the atoms are placed randomly along the waveguide, photons are emitted with random phase relations. However, our simulations show that even with complete disorder, there is still superradiance with the total emission rate scaling as the square of total number of spins [lower panel of Fig. 1 (a)].

¹We acknowledge support by the German Research Foundation (522216022). This research is part of the Munich Quantum Valley, which is supported by the Bavarian state government with funds from the Hightech Agenda Bayern Plus.

²Department of Mathematical Sciences, University of Copenhagen, Universitetsparken 5, 2200 Copenhagen, Denmark

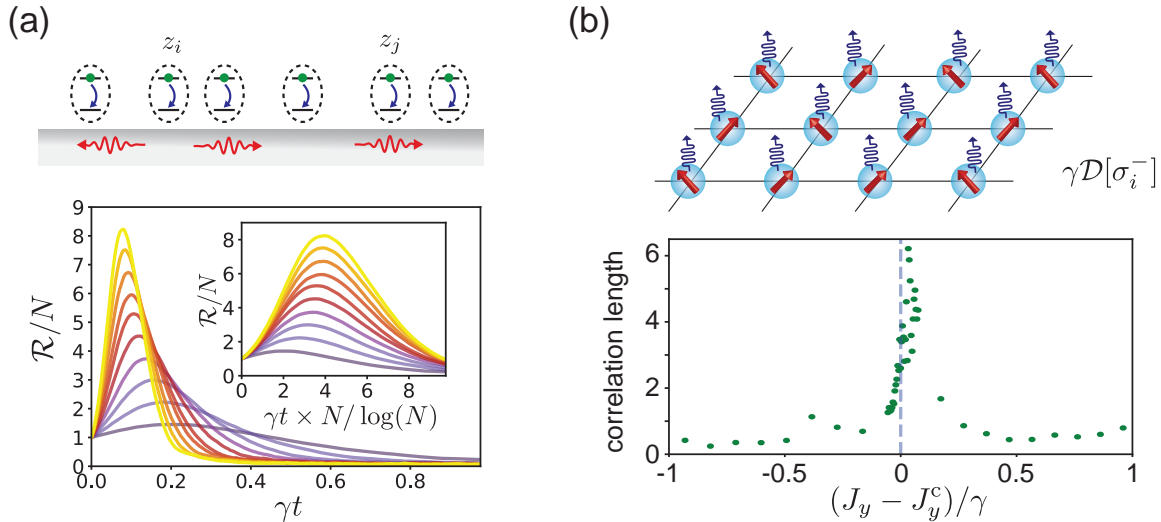

Figure 1: (a) Disordered superradiance. A large number of N two-level emitters with random positions are coupled to a common 1D waveguide. The lower panel shows the time evolution of the average decay rate per qubit, \mathcal{R}/N , with increasing N . (b) Schematic of a 2D dissipative Heisenberg XYZ model. At the critical point J_y^c our DTWA simulations of a spin lattice of size 36×36 clearly capture the expected divergence of the correlation length.

Dissipative Criticality

Quantum phase transitions and their associated critical behavior are a central theme of many-body physics. As another example of showcasing the power of DTWA, we study critical phenomena in a 2D dissipative Heisenberg XYZ model [Fig. 1 (b)], described by the Hamiltonian

$$H = \sum_{\langle i,j \rangle} J_x \sigma_i^x \sigma_j^x + J_y \sigma_i^y \sigma_j^y + J_z \sigma_i^z \sigma_j^z, \quad (2)$$

and local decays given by a dissipator $\mathcal{D}[\sigma_j^-]$ for each spin. It has been predicted [6] that, with $J_z = 1$, $J_x = 0.9$, there is a second-order phase transition at $J_y \approx 1.04$, from a paramagnetic to a ferromagnetic phase. A hallmark of criticality is scale invariance of length scale. That means, we should observe that correlation functions scale as a power law and that the correlation length diverges around the critical point. In the lower panel of Fig. 1(b), we successfully capture the divergence of the correlation function. It shows that DTWA can work in some cases with even short-range interactions, and the fluctuations included can well approximate large critical fluctuations.

References

- [1] J. Schachenmayer, A. Pikovski, and A. M. Rey, *Phys. Rev. X* **5**, 011022 (2015).
- [2] J. Huber, A. M. Rey, and P. Rabl, *Phys. Rev. A* **105**, 013716 (2022).
- [3] C. D. Mink, D. Petrosyan, and M. Fleischhauer, *Phys. Rev. Res.* **4**, 043136 (2022).
- [4] R. H. Dicke, *Phys. Rev.* **93**, 99–110 (1954).
- [5] M. Gross, and S. Haroche, *Phys. Rep.* **93**, 301–396 (1982).
- [6] T. E. Lee, S. Gopalakrishnan, and M. D. Lukin, *Phys. Rev. Lett.* **110**, 257204 (2013).

A Bosonic Cascade Laser

L. Garbe, L. Schamriß, P. Rabl ¹

In this project, we investigate the use of environment-assisted nonreciprocal transport. Achieving non-reciprocal processes is of prime importance for applications such as amplification or sensing, especially in superconducting circuits platforms. In particular, developing techniques that do not require large magnetic fields is a key requirement. One such alternative is provided by the use of parametric processes and dissipation. The elementary concept is illustrated in Fig. 1; three cavities \hat{a}_1 , \hat{a}_2 and \hat{a}_w are coupled via a non-linear element. By driving the latter at a frequency $\omega_2 + \omega_w - \omega_1$, one achieves a three-wave mixing process $\hat{a}_1\hat{a}_2^\dagger\hat{a}_w^\dagger + h.c.$, whereby the transfer of a single boson from mode 1 to mode 2 generates an extra excitation in the w (“waste”) mode. When the latter is strongly dissipative, this excitation is quickly lost to the environment; the net process is then an incoherent, irreversible transfer from mode 1 to 2, which may be described by a Lindblad equation of the form $\mathcal{L} = D[\hat{a}_1\hat{a}_2^\dagger]$.

Such processes are currently being used by experimental groups of at the WMI; in particular, the team led by K. Fedorov and R. Gross explores how this irreversible frequency conversion could be used for microwave detection, by transferring an incoming photon into a qubit while suppressing back-action [1].

Extending this idea to multiple cavities, one can achieve a transport scenario in which bosonic particles hop over an extended chain by interacting with their environment. Rightward and leftward hopping are driven by emission and absorption of energy to and from the bath, respectively. For a low-temperature environment, the asymmetry between absorption and emission events lead to non-reciprocal hopping over an extended chain.

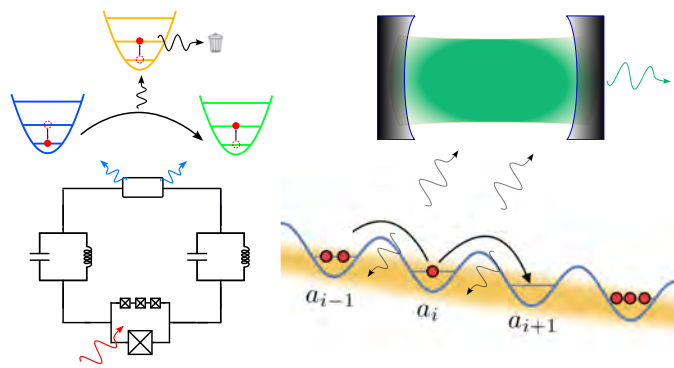

Figure 1: Left: illustration of dissipation-assisted nonreciprocal transfer. Right: generalization to an extended chain. As particles hop along the chain, part of the energy they emit is stored in a cavity mode, the rest dissipates into the environment.

In a previous analysis, which we concluded at the beginning of this year, we showed that the introduction of non-reciprocity has deep consequences for the transport properties. In particular, we observed the emergence of a very unusual phase, in which particles accumulate on a finite region at the edge of the chain, and experience Bose-Einstein condensation on every other site. This novel effect, which we baptized *bosonic skin effect*, can be connected to theoretical concepts that have been under intense scrutiny recently, in particular non-Hermitian Hamiltonians and Kardar-Parisi-Zhang dynamics. These results have been the topic of two articles, one published this year, and another currently under consideration for publication [2, 3].

Boson cascade laser

In those previous studies, the environment was used solely as a drain to evacuate the energy emitted by bosonic particles as they hop along the chain, thus suppressing their backward

¹We acknowledge support by the German Research Foundation (522216022). This research is part of the Munich Quantum Valley, which is supported by the Bavarian state government with funds from the Hightech Agenda Bayern Plus.

motion. If, however, a part of this energy is stored in a long-lived “cavity” mode, then transport in the chain may lead to accumulation of excitations, and eventually lasing, in the cavity mode. One thus obtains an equivalent of a quantum cascade laser, in which electrons in quantum wells are replaced with bosonic particles in the chain. The motion of particles in the chain induces lasing in the cavity, which in turns retroacts on their propagation speed.

This feedback between chain and cavity dynamics leads not only to lasing physics, but also to a pulsing behavior, whereby packets of particles slowly accumulate on the edge of the chain, before abruptly accelerating and propagating down the chain; simultaneously, the cavity population experiences a sudden, intense pulse (see Fig. 2). Importantly, these “avalanches” can even be triggered by a single particle in the chain; we have started to investigate how this mechanism could be exploited for particle detection. We are currently writing an article presenting these findings.

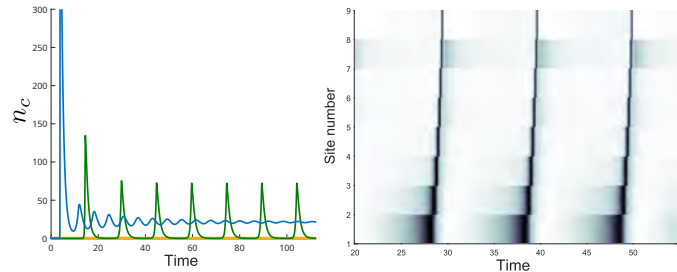

Figure 2: Left: cavity population versus time, showing lasing (blue) and pulsing (green) regimes. Right: space-time plot of the chain population, showing “avalanches” events.

cQED implementation

The second goal of our current work is to investigate practical schemes to implement this dynamics in superconducting circuits. In our forthcoming publication, we also propose an architecture that utilizes a series of superconducting nonlinear elements (SNAIL) to implement the boson cascade laser discussed above. As already mentioned, all the elements required to realize this scheme are being used by experimental groups at the WMI, and we are now studying how a two-site proof-of-principle may be realized in these setups.

Another possible scheme, which is studied by Lukas Schamriß as a part of his Ph.D. work, consists of a superconducting waveguide terminated by a driven non-linear element. The latter induces transitions between the normal modes of the waveguide, which can then be seen as sites in an effective lattice (see Fig. 3). Such a design gives access to a sizeable number of “chain sites”, without the need for challenging fabrication process. We obtained first promising results showing how this process leads to Bose-Einstein condensation in the lowest mode of the waveguide.

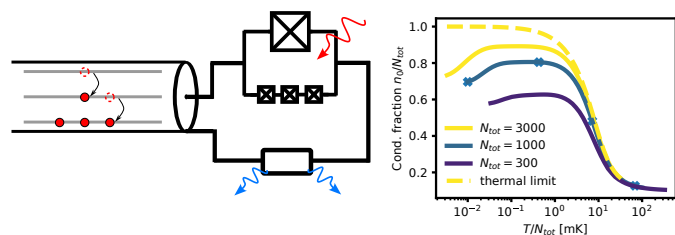

Figure 3: Left: alternative design for non-reciprocal transport, using a superconducting waveguide coupled to a dissipative element. Right: population fraction in the lowest mode versus temperature. Below a certain critical temperature, a macroscopic number of excitation accumulate in the ground mode, an evidence of Bose-Einstein condensation.

References

- [1] Y. Nojiri, K. E. Honasoge, A. Marx, K. G. Fedorov, and R. Gross, *Physical Review B* **109**, 174312 (2024).
- [2] L. Garbe, Y. Minoguchi, J. Huber, and P. Rabl, *SciPost Physics* **16**, 029 (2024).
- [3] Y. Minoguchi, J. Huber, L. Garbe, A. Gambassi, and P. Rabl, [arXiv.2311.10138](https://arxiv.org/abs/2311.10138) (2023).

Bosonic and Fermionic Impurity Models in Circuit QED

*A. P. Misselwitz, P. Schulze-Hagen, J. Luneau, F. Roy, K. Liegener, P. Rabl*¹

Superconducting quantum processors such as those developed in the WMI is a promising platform for analog quantum simulation of many-body systems. One-dimensional arrays of capacitively superconducting circuits are naturally described by a one-dimensional bosonic Hamiltonian. The non-linearity of the superconducting elements leads to an interaction between the bosons. Fermionic models in one dimension can also be simulated in circuit-QED using the Jordan-Wigner transformation to map them on a bosonic Hamiltonian. Each superconducting circuit of the array can be engineered with controlled physical properties (resonance frequency, non-linearity, or coupling to its neighbors). This ability is very promising to study bosonic and fermionic impurity models in circuit QED. We study theoretically such models and identify their experimental signatures in a quantum simulation with superconducting circuits.

Waveguide-QED with interacting photons

Waveguide-QED systems correspond to two-level emitters coupled to electromagnetic modes propagating in one dimension. This can be realized by coupling superconducting circuits in the qubit regime accounting for the atom (in orange in Fig. 1) to a chain of weakly non-linear superconducting resonators accounting for the waveguide (referred to as cavities, in blue in Fig. 1). Such a system can be interpreted as a bosonic periodic impurity model described by

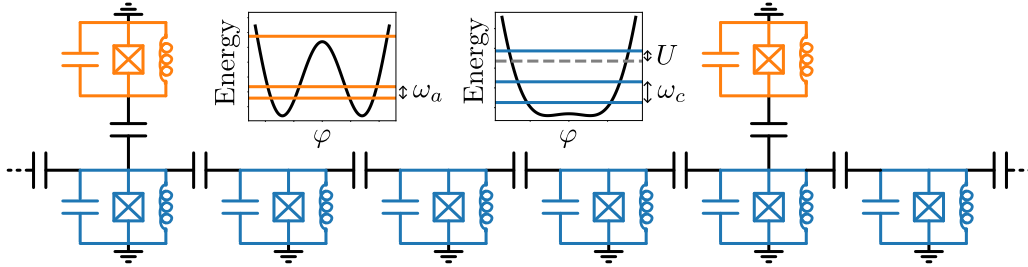

Figure 1: Waveguide QED with interacting photons. The two-level emitters (in orange) are realized by highly non-linear superconducting circuits. The waveguide is a chain of capacitively coupled superconducting circuits. Their anharmonicity U induces interaction between the photons propagating in the waveguide.

the Hamiltonian

$$H = \frac{\omega_a}{2} \sum_i \sigma_z^i + \omega_c \sum_x a_x^\dagger a_x - J \sum_x (a_x^\dagger a_{x-1} + \text{h.c.}) + \frac{U}{2} \sum_x a_x^\dagger a_x^\dagger a_x a_x + g \sum_i (a_{x_i} \sigma_+^i + a_{x_i}^\dagger \sigma_-^i),$$

where U is the cavity non-linearity, J is the coupling between cavities, and g is the atom-cavity coupling. The total number of excitation is conserved in such a model, enabling us to study the few-excitations ground state properties in the case of a small tunnel coupling J . In the absence of photonic interactions U , a strong coupling to the atom g creates multi-photon eigenstates bound to the atoms [1]. We showed that the photonic interaction competes with the cavity-atom interaction, leading to different phases of multi-photon bound states, see Fig. 2(a).

¹We acknowledge support by the German Research Foundation (522216022). This research is part of the Munich Quantum Valley, which is supported by the Bavarian state government with funds from the Hightech Agenda Bayern Plus.

Interestingly, as shown in Fig. 2(b), long-range correlations between the atoms appear at the transition lines between the different phases, while the phases themselves are insulating with an exponential decay of correlation functions. Such novel correlated many-body phases may be probed experimentally on the circuit-QED platforms developed at WMI.

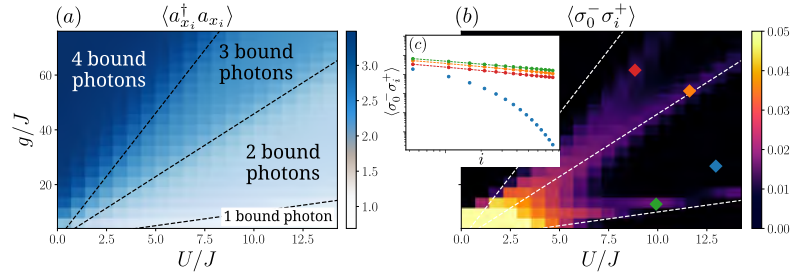

Figure 2: Ground state phases of the bosonic impurity model with 4 excitations per unit-cell. (a) Average photon number of a cavity coupled to a qubit. The number of bound photons depends on the photon-photon interaction U and cavity-atom coupling g . (b) Long-range correlations between the atoms appearing near the transition lines between the different multi-photon bound phases. (c) In green, orange, red, algebraic decay of the atom-atom correlations on the transition lines. In blue, exponential decay of the correlations in the insulating phases.

Kondo impurity models in circuit-QED

The Anderson model describes the influence of a magnetic impurity on the conduction electrons of a metal. The electronic Coulomb interaction on the impurity leads to a many-body correlated ground state, the so-called Kondo singlet, between the collective electronic spins in the vicinity of the impurity. The Hamiltonian of the model is expressed in terms of fermionic operators $a_{i,\uparrow,\downarrow}$, $d_{\uparrow,\downarrow}$, accounting for the electrons in the metal and on the impurity site, as

$$H = -t \sum_{\langle i,j \rangle, \sigma} \left(a_{i,\sigma}^\dagger a_{j,\sigma} + \text{h.c.} \right) + U \sum_i a_{i,\uparrow}^\dagger a_{i,\uparrow} a_{i,\downarrow}^\dagger a_{i,\downarrow} - J \sum_\sigma \left(a_{0,\sigma}^\dagger d_\sigma + \text{h.c.} \right) - \epsilon \sum_\sigma d_\sigma^\dagger d_\sigma + V d_\uparrow^\dagger d_\uparrow d_\downarrow^\dagger d_\downarrow.$$

It can be simulated in circuit-QED in one-dimension using the Jordan-Wigner transformation to translate the fermionic operators into bosonic ones. The spin is encoded by doubling the chain of bosonic modes, with cross-Kerr interaction accounting for the Coulomb interaction, and the first site detuning encoding the impurity occupation energy [Fig. 3(a)]. Varying the impurity cross-Kerr interaction leads to the many-body singlet phase with long-range spin-spin correlations characterized by $\Sigma_\chi = \sum_i \langle S_{\text{impurity}}^z S_i^z \rangle = -1/4$ [Fig. 3(b)]. The preparation and characterization of such many-body correlated state will be a test case for the superconducting quantum processors developed in the WMI.

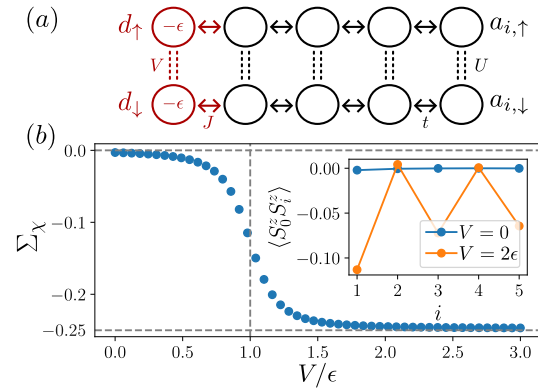

Figure 3: (a) Double chain of bosonic modes encoding the Anderson fermionic impurity model after Jordan-Wigner transformation. The Coulomb interaction translates into a cross-Kerr interaction (double dashed lines). The detuned first site encodes the impurity. (b) Long-range correlations of the Kondo singlet appear when increasing the impurity cross-Kerr interaction V .

References

- [1] G. Calajó, F. Ciccarello, D. Chang, and P. Rabl, *Phys. Rev. A* **93**, 033833 (2016).

Impact of Growth Conditions on Magnetic Anisotropy and Magnon Hanle Effect in α -Fe₂O₃

M. Scheufele, J. Gückelhorn, M. Opel, H. Huebl, R. Gross, S. Geprägs, M. Althammer¹
A. Kamra²

The quantized excitations in magnetically ordered materials, i.e. magnons, are highly sensitive to the magnetic anisotropy of their host material. Thus, the possibility to understand and control magnetic anisotropy is crucial in magnonics, especially within antiferromagnetic systems composed of two magnetic sublattices. These systems exhibit degenerate magnon modes, characterized by opposite precession chiralities [1, 2].

At WMI, we focus on the antiferromagnetic insulator hematite (α -Fe₂O₃) [2–5], known for its Morin transition at $T_M \approx 263$ K. Above T_M , magnetic moments align in the magnetic easy α -Fe₂O₃ (0001)-plane, and the Dzyaloshinskii–Moriya interaction (DMI) induces finite spin canting, resulting in a net magnetization. Below T_M , the magnetic anisotropy transitions to an uniaxial easy-axis configuration, causing a reorientation of the magnetic moments along the [0001]-axis, and an elimination of spin canting and correspondingly net magnetization. In the easy-plane phase, we observed the magnon Hanle effect and introduced the concept of pseudospin to describe the time evolution of magnon modes, including their superpositions [1, 2]. This magnon Hanle effect is expected to vanish in the easy-axis phase. Notably, in thin α -Fe₂O₃ films, the Morin transition is often suppressed due to growth-induced anisotropy changes. We have optimized the growth conditions to tune magnetic anisotropy, thereby recovering the Morin transition, and shift T_M to finite temperatures even in thin α -Fe₂O₃ films. This is crucial for novel spintronics applications and necessary to observe the magnon Hanle effect [5].

We prepared epitaxial α -Fe₂O₃ films on Al₂O₃ (0001) substrates via pulsed laser deposition (PLD) in a molecular oxygen atmosphere. To reduce oxygen vacancies, we furthermore grew α -Fe₂O₃ films while operating an additional atomic oxygen source (AOS). We distinguish between NAOS-Fe₂O₃ (no AOS used) and AOS-Fe₂O₃ (AOS used) films [5]. By SQUID magnetometry, we measured the $M(T)$ dependence shown in Fig. 1. The NAOS-Fe₂O₃ films exhibit no transitions from 300 K down to 10 K, staying in the easy-plane phase with finite DMI-induced net magnetization. Contrarily, AOS-Fe₂O₃ films show Morin transitions at $T_M \approx 205$ K for thick and $T_M \approx 125$ K for thin films. Atomic oxygen during the PLD process appears to reduce the amount of oxygen vacancies and alters magnetic anisotropy as compared to oxygen-deficient NAOS-Fe₂O₃ films. A second transition at $T_M^* \approx 125$ K in the thick AOS-Fe₂O₃ film suggests multiple hematite phases with distinct magnetic anisotropies. While we expect M to vanish below T_M , a finite magnetization persists, suggesting incomplete spin reorientation and coexisting

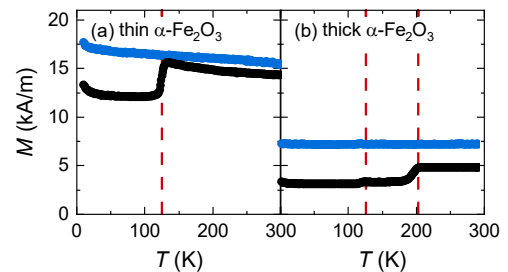

Figure 1: Temperature dependence of magnetization M of α -Fe₂O₃ films with (a) 25 nm (NAOS-Fe₂O₃, blue) and 19 nm (AOS-Fe₂O₃, black) and (b) 103 nm (blue) and 89 nm thickness (black). Red dashed lines indicate the Morin transitions in AOS-Fe₂O₃. Measurements were conducted while heating the samples in an in-plane magnetic field of $\mu_0 H = 100$ mT after zero-field cooling. A diamagnetic background signal was subtracted from the data.

¹Financial support by the German Research Foundation via Germany’s Excellence Strategy (EXC-2111-390814868) is gratefully acknowledged. This research is part of the Munich Quantum Valley, which is supported by the Bavarian state government with funds from the Hightech Agenda Bayern Plus.

²Condensed Matter Physics Center (IFIMAC) and Departamento de Física Teórica de la Materia Condensada, Universidad Autónoma de Madrid, 28049 Madrid, Spain

easy-plane and easy-axis phases below T_M . Notably, M is higher in thinner films, potentially linked to DMI, exchange coupling, or magnetic anisotropy changes.

We then investigated all-electrical magnon transport in these α -Fe₂O₃ films by injecting a DC charge current I_{inj} in one Pt electrode, which generates a spin current via the spin Hall effect (SHE). The excited diffusive magnon current is then detected as a voltage V_{det} in the second Pt electrode via the inverse SHE (Fig. 2 (a)). We extract the electrically induced magnon spin signal $R_{det}^{el} = V_{det}/I_{inj}$ and its amplitude $\Delta R_{det}^{el} = R_{det}^{el}(\varphi = 270^\circ) - R_{det}^{el}(\varphi = 180^\circ)$ as shown in Fig. 2 (b)-(e) as a function of $\mu_0 H$ in the easy-plane phase of α -Fe₂O₃. The NAOS-Fe₂O₃ films exhibit the characteristic magnon Hanle curve previously discovered at WMI [2], with ΔR_{det}^{el} peaking at a compensation field $\mu_0 H_c \approx 8$ T and 5.4 T (Fig. 2 (b, c)).

In contrast, we observe a decrease in $\mu_0 H_c$ for devices on AOS-Fe₂O₃ films (see dashed lines in Fig. 2 (d, e)). At $\mu_0 H_c$, the external magnetic field compensates the easy-plane anisotropy field in α -Fe₂O₃ resulting in a vanishing pseudofield. Therefore, the shift is associated with a change in magnetic anisotropy. Moreover, ΔR_{det}^{el} is higher in (d, e), indicating reduced magnetic damping due to fewer oxygen vacancies [2].

In summary, α -Fe₂O₃ films grown in additional atomic oxygen exhibit a finite Morin transition even at 19 nm thickness at around $T_M = 125$ K. Moreover, growth of α -Fe₂O₃ in atomic oxygen reduces magnon scattering and thus increases the magnon spin signal at the compensation field, while the latter is shifted to lower values on the field axis. Our results show that adjusting the oxygen content in α -Fe₂O₃ tunes magnetic anisotropy and offers a pathway to a finite T_M in hematite films below 100 nm thickness, providing new insights into the role of magnetic anisotropy on the magnon Hanle effect [5].

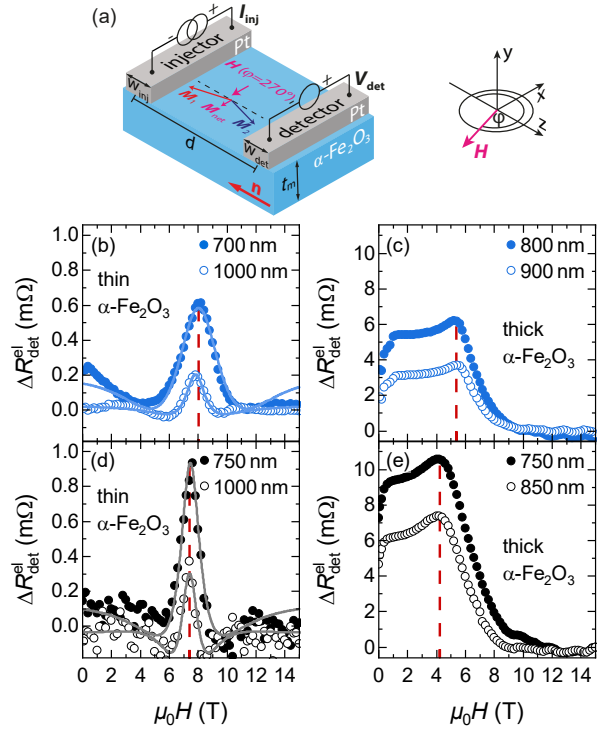

Figure 2: (a) Sample configuration: Pt strips placed on a α -Fe₂O₃ film in the magnetic (0001) easy-plane phase. The canted sublattice magnetizations $M_{1,2}$ induce a net magnetization M_{net} oriented by an in-plane magnetic field H at angle φ , with the Néel order parameter $n \perp H$. A charge current through the left Pt-electrode generates magnons, detected as a voltage at the right Pt-electrode. (b)-(e) Electrically induced magnon spin signal amplitude $\Delta R_{det}^{el}(\mu_0 H)$ at 200 K for thin (left) and thick (right) films with varying injector-detector separations d (full/open circles). The 19 nm and 89 nm thick AOS-Fe₂O₃ films (d, e) show higher ΔR_{det}^{el} than the 15 nm and 103 nm thick NAOS-Fe₂O₃ films (b), (c). Red dashed lines indicate the compensation fields $\mu_0 H_c$.

References

- [1] A. Kamra, T. Wimmer, H. Huebl, and M. Althammer, *Phys. Rev. B* **102**, 174445 (2020).
- [2] T. Wimmer, A. Kamra, J. Gückelhorn, M. Opel, S. Geprägs, R. Gross, H. Huebl, and M. Althammer, *Phys. Rev. Lett.* **125**, 247204 (2020).
- [3] J. Gückelhorn, A. Kamra, H. Huebl, M. Opel, S. Geprägs, R. Gross, H. Huebl, and M. Althammer, *Phys. Rev. B* **105**, 094440 (2022).
- [4] J. Gückelhorn, S. de-la Peña, M. Scheufele, M. Grammer, M. Opel, S. Geprägs, J. C. Cuevas, R. Gross, H. Huebl, A. Kamra, and M. Althammer, *Phys. Rev. Lett.* **130**, 216703 (2023).
- [5] M. Scheufele, J. Gückelhorn, M. Opel, A. Kamra, H. Huebl, R. Gross, S. Geprägs, and M. Althammer, *APL Materials* **11**, 091115 (2023).

Electrically Induced Angular Momentum Flow between Separated Ferromagnets

M. Grammer, T. Wimmer, J. Gückelhorn, L. Flacke, R. Gross, H. Huebl, M. Althammer¹
R. Schlitz, S. Goennenwein², A. Kamra³

At WMI, a central focus in spintronics research has been on angular momentum transport via magnons in epitaxial thin films of ferromagnetic or antiferromagnetic insulators [1]. In Schlitz *et al.* [2], we demonstrate angular momentum transport between two ferromagnetic metal electrodes in the absence of a thin film epitaxial magnetic insulator used as a common substrate. This approach opens new research directions, as the angular momentum transport is realized by dipolar coupling and potentially by incoherent elastic excitations.

In your experimental setup, two isolated ferromagnetic (FM) metal strips are positioned on top of a diamagnetic insulator (DI) substrate, which provides rigid support and enables angular momentum transport between the strips while ensuring electrical isolation. A schematic of this setup is depicted in Fig. 1(a) with the two electrodes serving as an injector (FM1) and a detector (FM2) with a separation d and width w . When a sufficiently large magnetic field H is applied to align the magnetization M along the surface normal and a charge current I_{inj} is driven through the injector, we observe a finite voltage V_{det} in the adjacent detector electrode. In Fig. 1(b), we show the detected voltage V_{det} for a Ni-Ni structure as a function of the magnetic field orientation in three orthogonal rotation planes [see Fig. 1(d)-(f)] with the corresponding rotation angles α, β, γ . The measured detector voltage shows a $\cos^2(\beta, \gamma)$ dependence with a maximum signal when M is pointing along the surface normal while V_{det} vanishes within our experimental resolution when the magnetization is oriented in the sample plane. If we replace one of the FM electrodes with Pt, which is a non-magnetic metal with strong spin-orbit coupling, the signal vanishes for all field orientations, showing that a purely electronic spin accumulation is insufficient to observe the signal as shown in Fig. 1(c).

To qualitatively explain the origin and shape of V_{det} , we first consider the situation in the injector wire (FM1) with the magnetization M_1

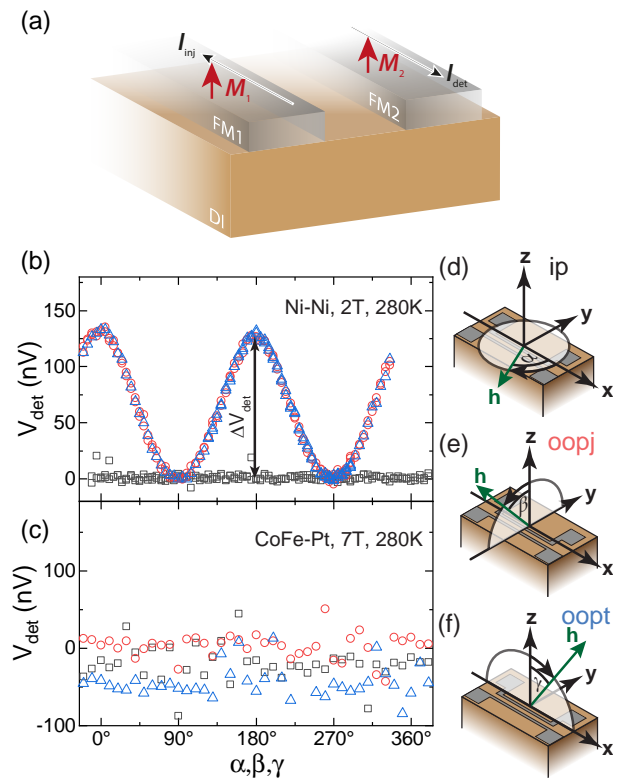

Figure 1: (a) Sketch of the sample geometry with the magnetization M of the ferromagnetic electrodes oriented along the surface normal. (b,c) Angle-dependence of V_{det} for Ni-Ni strips (panel b) and CoFe-Pt strips (panel c) obtained at 280 K and $\mu_0 H = 2$ T, 7 T. Black squares correspond to ip-rotations, red circles to oopj-rotations and blue triangles to oopt rotations, respectively. (d,e,f) Illustration of the rotation planes used for the angle-dependent measurements: in-plane rotation (d, ip), out-of-plane perpendicular to j (e, oopj), and out-of-plane perpendicular to t (f, oopt).

¹We gratefully acknowledge financial support from the German Research Foundation under Germany's Excellence Strategy – EXC-2111 – 390814868

²Department of Physics, University of Konstanz, 78457 Konstanz, Germany

³Department of Physics, RPTU Kaiserslautern-Landau, 67663 Kaiserslautern, Germany

oriented along the z -axis (see Fig. 2(a)). The applied charge current flowing within the ferromagnet is converted into a spin current by the anomalous spin Hall effect (SHE) that results in an electronic spin accumulation (described via the electron spin chemical potential μ_{el}) at the two sides of the wire within the electronic spin decay length λ_{el} . The electronic spin accumulation interacts with the thermally occupied magnon bath within the ferromagnetic electrode at elevated temperatures via inelastic spin-flip scattering. This allows the transfer of angular momentum from the electronic to the magnonic system and the generation of a non-equilibrium magnon accumulation at the side edges of the electrode with a characteristic magnon decay length λ_m (see Fig. 2(a)). Angular momentum can then be transported to the second electrode via magnetic dipolar coupling and potentially through incoherent phonon-mediated spin transport. This results in a magnonic spin accumulation at the second ferromagnet, driving an electronic spin current, which is then converted into a charge current I_{det} by the inverse charge-to-spin current conversion processes.

If the magnetization in the FM wires is oriented within the sample plane [see Fig. 2(b)] the SHE gives rise to an electronic spin accumulation at the top and the bottom of the FM electrode that in turn results in a magnon accumulation and magnon depletion, respectively. However, as the thickness t of the FM wire is much smaller than λ_m , those opposite contributions cancel and lead to a vanishing non-equilibrium magnon accumulation. Thus, there is no angular momentum transport between the two FM strips. We conclude that a finite angular momentum transport signal only occurs when the magnetization directions of the ferromagnetic strips have a nonzero projection on the surface normal. This results in a $\cos(\beta, \gamma)$ contribution from each FM strip and thus to the observed $\cos^2(\beta, \gamma)$ behavior shown in Fig. 1(b).

In summary, we established a new way to transport angular momentum between two FM electrodes by all-electrical means. This approach allows us to study the underlying concepts based on charge-to-spin current conversion in the metallic ferromagnets, the interplay of the accumulated electron spin with the thermal magnon gas, and last but not least, the dipolar and potential phononic spin transport between the ferromagnetic strips.

References

- [1] J. Gückelhorn, S. de-la Peña, M. Scheufele, M. Grammer, M. Opel, S. Geprägs, J. C. Cuevas, R. Gross, H. Huebl, A. Kamra et al., *Physical Review Letters* **130**, 216703 (2023).
- [2] R. Schlitz, M. Grammer, T. Wimmer, J. Gückelhorn, L. Flacke, S. T. Goennenwein, R. Gross, H. Huebl, A. Kamra, and M. Althammer, *Physical Review Letters* **132**, 256701 (2024).

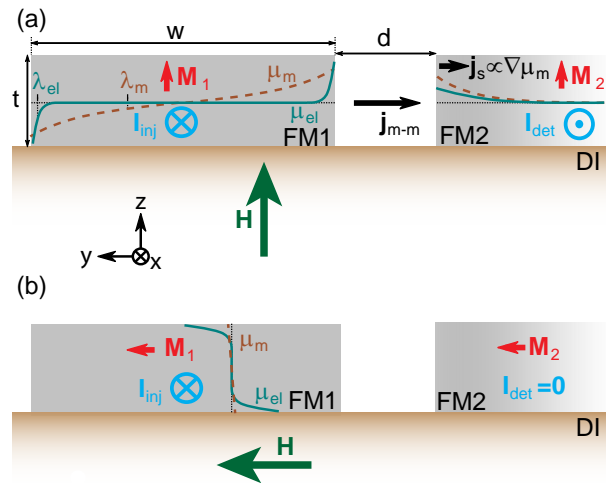

Figure 2: (a) Spin transport experiments with the magnetic field pointing out of the sample plane. Charge-to-spin conversion leads to an electronic spin accumulation μ_{el} at the edges of the FM1 layer upon application of a current I_{inj} with the spin polarization oriented along the magnetization \mathbf{M} . The electronic spin accumulation gives rise to a magnon chemical potential μ_m , which relaxes on the scale of the magnon diffusion length λ_m , which exceeds the electronic spin diffusion length λ_{el} . The finite magnon accumulation at the right side couples to the thermal magnon bath in the FM2 strip by dipolar coupling and via phonon spin transport through the DI and thereby induces a dc current I_{det} in the FM2 strip by spin-to-charge conversion. (b) Illustration of the chemical potential profiles for \mathbf{M} within the sample plane. The electron spin accumulation is now at the top and bottom surfaces and fails to generate any substantial magnon chemical potential as $t \ll \lambda_m$. Thus, no angular momentum transport signal is observed in the detector.

Resonant Magneto-Elastic Coupling in Cobaltiron Thin Films - Sapphire Substrate Bilayers

J. Weber, M. Müller, T. Luschmann, M. Opel, S. Geprägs, R. Gross, M. Althammer, H. Huebl¹
 F. Engelhardt, M. Cherkasskii, S. Viola Kusminskiy,² V. A. S. V. Bittencourt,³
 S. T. B. Goennenwein⁴

At WMI we recently studied the resonant coupling between magnetic excitations in magnetic thin films and elastic excitations distributed over magnetic/substrate bilayer structure. These studies address aspects of phonon-induced magnetization damping and the angular momentum transfer between magnetic and elastic excitations. Conceptually, we investigate, how the magnetization excitation with its sense of precession couples via the magnetoelastic interaction to the acoustic phonons of the entire sample stack, which forms a high overtone bulk acoustic resonator. For our experiments, we fabricated a bulk acoustic wave resonator consisting of a $\text{Co}_{25}\text{Fe}_{75}$ thin film with a thickness $d = 30$ nm deposited on top of a crystalline (0001)-oriented sapphire substrate polished on both sides with thickness $L = 510$ μm . We performed broadband ferromagnetic resonance (bbFMR) measurements (Ref. [1]) to interrogate the coupled bilayer system. To this end, we mount the sample with the metal thin film facing the coplanar waveguide (CPW). We perform our bbFMR experiments in the so-called out-of-plane configuration, where the magnetization and the externally applied magnetic field H_{ext} are aligned along the sample normal.

The excited ferromagnetic resonance mode can couple to the fast and slow transverse acoustic phonon modes in the substrate (v_{st} and v_{ft}) with orthogonal polarizations as shown in Fig. 1 (a). This leads to the formation of standing waves across the sample thickness due to reflective boundary conditions at the surfaces because of the finite thickness $L + d$ of the sample. The frequency of the modes of the high-overtone bulk acoustic wave resonator (BAWR) are given by:

$$f_{n,i} = \frac{n}{2 \left(\frac{d}{\tilde{v}_t} + \frac{L}{v_i} \right)}, \quad (1)$$

where $i = \text{st}, \text{vt}$ are the slow and fast transverse acoustic sound velocities of the substrate and \tilde{v}_t is the transverse acoustic sound velocity of the magnetic layer. The periodicity is given by the free-spectral-range (FSR) $f_{\text{FSR}} = f_{n+1,i} - f_{n,i} = f_{1,i}$.

Fig. 1 (b) shows the microwave spectroscopy data as complex transmission coefficient S_{21} . We find the characteristic absorption dip of the Kittel mode within a smaller frequency range of $\Delta f = 20$ MHz around $f_0 = 18$ GHz. Notably, this data shows a distinct frequency periodic pattern of a double peak signature with a frequency spacing of $f_{\text{FSR}} = 6.04$ MHz. This is in excellent agreement with $f_{\text{FSR},i} = 6.05$ MHz calculated from Eq. (1) using the sample thickness of the substrate $L = 510$ μm , the shear wave velocity of sapphire $v_i \approx 6.17$ km/s, and the parameters of the magnetic thin film $d = 30$ nm and $\tilde{v}_t = 3.17$ km/s. The double peak signature

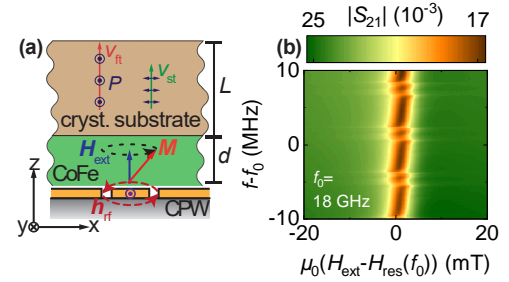

Figure 1: (a) Schematic of the bulk acoustic wave resonator mounted on top of a CPW. The driven ferromagnetic resonance mode can couple to the transverse acoustic phonon modes that form standing waves in the sample. (b) Microwave transmission magnitude S_{21} as a function of the external magnetic field $\mu_0 H_{\text{ext}}$ around $H_{\text{res}}(f_0) = 3.005$ T and the applied microwave frequency f around $f_0 = 18$ GHz measured at $T = 5$ K.

¹We acknowledge financial support from the German Research Foundation via the Collaborative Research Center TRR 360 (Project-ID: 492547816) Constrained Quantum Matter

²Institute for Theoretical Solid State Physics, RWTH Aachen University, 52074 Aachen, Germany

³ISIS (UMR 7006), Université de Strasbourg, 67000 Strasbourg, France

⁴Department of Physics, University of Konstanz, 78457 Konstanz, Germany

with a frequency spacing of $\Delta f_i = 1.4$ MHz is attributed to two non-degenerate transverse acoustic phonon modes in the substrate whose sound velocities differ by $\Delta v_t = 0.5$ m/s. This is due to a non-perfect alignment between the (0001)-direction of the crystalline structure of the substrate and the z-axis. The two transverse acoustic phonon modes are degenerate along this high symmetry crystalline axis and due to a small miscut-angle their sound velocities start to differ, reflecting the properties of the phonon dispersion relations of sapphire. From this small difference in the transverse acoustic sound velocities, we calculate the miscut-angle of the crystalline substrate to $\theta_m^{\text{MEC}} = 0.017^\circ$. This value is in good agreement with an independent XRD measurement yielding $\theta_m^{\text{XRD}} = 0.011(2)^\circ$. Furthermore we were able to demonstrate MEC and the splitting of the transverse acoustic phonon modes for CoFe deposited on a Gadolinium-Gallium-Garnet substrate (111) and a Silicon substrate (001) (Ref. [2]). Since the free-spectral-range is calculated from temperature dependent parameters like the sound velocity and thickness of the substrate and magnetic thin film, we performed a temperature dependent analysis of the fitted FMR linewidth change $\Delta H_{\text{MEC}} = \Delta H - \Delta H_0$, where ΔH is the FMR linewidth obtained by fitting the complex transmission parameter S_{21} to the Polder susceptibility (Ref. [1]) and ΔH_0 is the uncoupled FMR linewidth around $f_0 = 18$ GHz in a fixed frequency window of $\Delta f = 20$ MHz around f_0 from $T = 5$ K up to $T = 300$ K as shown in Fig. 2 (a).

The measured free-spectral range is then plotted as a function of the temperature and shows a monotonic decrease towards higher temperatures in Fig. 2 (b). We neglect the temperature dependence of the acoustic parameters of the magnetic layer since its thickness ($d \approx 30$ nm) is small compared to the substrate thickness ($L \approx 510$ μm). Thus, the temperature dependent acoustic properties are dominated by the acoustic parameters of the substrate. We account for the temperature dependence of the substrate thickness $L(T)$ and the transverse acoustic sound velocities $v_i(T) = \sqrt{G(T)/\rho(T)}$, where $G(T)$ and $\rho(T)$ are the shear modulus and the density of the substrate, respectively. We then calculate the temperature evolution of the free-spectral range using literature values for the temperature dependence of the sapphire parameters as a red line in Fig. 2 (b). We find excellent agreement between the calculated free-spectral range and the measured f_{FSR} . This indicates that our experimental method is suited to study the temperature dependence of the acoustic parameters of the substrate material (for more details see Ref. [3]).

In conclusion, we established a thin film metallic ferromagnet for MEC experiments, with the perspective of studying MEC in the strong coupling regime for thinner substrates.

References

- [1] H. Maier-Flaig, S. T. B. Goennenwein, R. Ohshima, M. Shiraiishi, R. Gross, H. Huebl, and M. Weiler, *Review of Scientific Instruments* **89**, 076101 (2018).
- [2] M. Müller, J. Weber, F. Engelhardt, V. A. S. V. Bittencourt, T. Luschmann, M. Cherkasskii, M. Opel, S. T. B. Goennenwein, S. Viola Kusminskiy, S. Geprägs, R. Gross, M. Althammer, and H. Huebl, *Phys. Rev. B* **109**, 024430 (2024).
- [3] M. Müller, J. Weber, S. Goennenwein, S. V. Kusminskiy, R. Gross, M. Althammer, and H. Huebl, *Phys. Rev. Appl.* **21**, 034032 (2024).

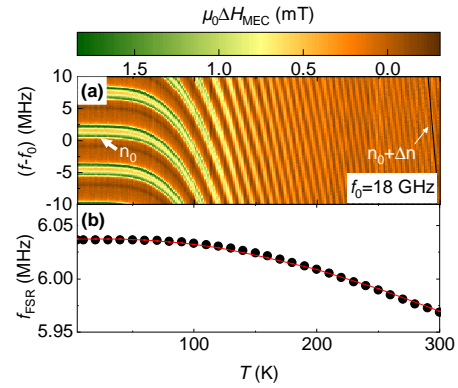

Figure 2: (a) Difference of the fitted FMR linewidth ΔH and the base linewidth ΔH_0 as a function of microwave frequency f around $f_0 = 18$ GHz and temperature T . (b) Free spectral range f_{FSR} as a function of T . The red continues line shows the calculated theoretical behavior using Eq. (1).

High-Precision Broadband ESR Spectroscopy of Rare-Earth Ions in CaWO_4

G. Mair, A. Strinic, C. Fu, A. Marx, K. G. Fedorov, H. Huebl, R. Gross, N. Kukharchyk¹

Hybrid systems are a key building block of scalable quantum technologies as they combine platforms with additive strengths. A versatile element of them are storage units with applications ranging from quantum computing to quantum communication [1, 2]. Diluted solid-state ensembles of rare-earth ions are highly suitable for quantum memory applications, as their Hahn-echo coherence times exceed milliseconds at low temperatures, allowing them to reach hours of coherent storage when applying dynamic decoupling techniques [3]. Trivalent erbium received particular attention not only in quantum memory but also in transduction applications due its optical transitions within the telecom C-band [4].

It is hence of great importance to understand the complex energy structure of rare-earth ions to identify the most suitable quantum memory transitions. To this end, we investigate the ground state of Er^{3+} ions embedded in a CaWO_4 crystal in the microwave regime. Due to the hyperfine interaction (H_{HF}) between the nuclear spin $I = 7/2$ and electron spin $S = 1/2$ of the $^{167}\text{Er}^{3+}$ isotope, these systems exhibit a rich microwave spectrum. In addition, the quadrupole moment of the nucleus yields a small energy shift of the levels (H_{Q}), which is only noticeable in sufficiently low magnetic fields where the Zeeman effect (H_{Z}) does not dominate. The full effective spin Hamiltonian thus reads

$$H_{\text{eff}} = H_{\text{Z}} + H_{\text{HF}} + H_{\text{Q}} = \mu_{\text{B}} \mathbf{B} \cdot \mathbf{g} \cdot \mathbf{S} + \mathbf{I} \cdot \mathbf{A} \cdot \mathbf{S} + \mathbf{I} \cdot \mathbf{Q} \cdot \mathbf{I},$$

where μ_{B} denotes the Bohr magneton, \mathbf{B} is the external field, and \mathbf{S} and \mathbf{I} are the spin operators of electron and nucleus, respectively. Close to zero-field, transition frequencies span below 4 GHz and exhibit zero first-order Zeeman shift (ZEFOZ) behavior, which allows for the longest natural coherence times due to enhanced insensitivity to fluctuations of external magnetic fields. The interaction tensors \mathbf{g} , \mathbf{A} and \mathbf{Q} reflect the tetragonal symmetry of the host crystal. Whereas the g -factors and hyperfine coefficients have been known by literature for decades, the quadrupole term remained neglected and unaccounted [5].

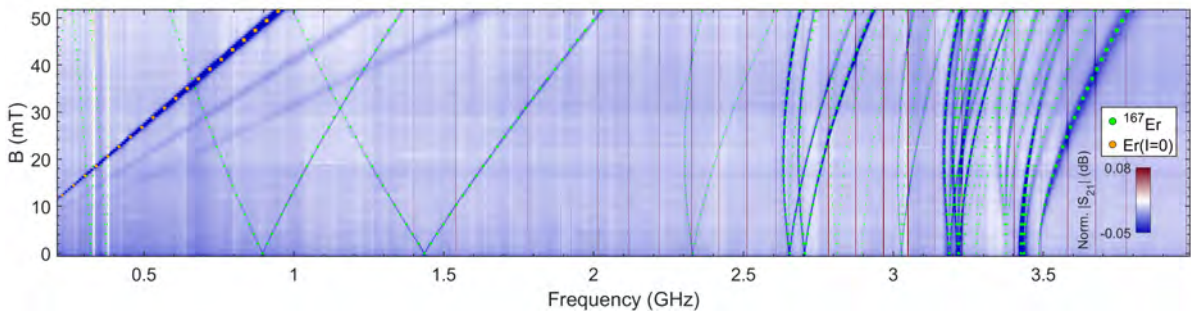

Figure 1: Broadband electron spin resonance allows to probe multiple allowed hyperfine levels of $\text{Er} : \text{CaWO}_4$ by measuring the microwave absorption as a function of both frequency and magnetic field B . The simulation (green circles) coincides with the experimental data only by assuming a non-vanishing quadrupole tensor \mathbf{Q} .

We employ broadband electron spin resonance (ESR) spectroscopy to probe spin transitions with a superconducting coplanar waveguide of niobium patterned on a silicon substrate. Cooling to temperatures below 10 mK ensures detectable population differences in the hyperfine levels. The sample is mounted on top of the waveguide so that spins in the vicinity

¹We acknowledge support by the German Research Foundation via Germany's Excellence Strategy (EXC 2111-390814868), and the German Federal Ministry of Education and Research via the project QuaMToMe (Grant No. 16KISQ036).

of the waveguide can interact with the magnetic field component of a traveling microwave. In contrast to the resonator approach commonly used in ESR, this allows to address all allowed spin transitions at any applied magnetic field. This direct type of absorption measurement enables a characterization of the Er^{3+} energy level structure with high precision. Fig. 1 shows a field-swept spectrum with the symmetry axis c of the crystal aligned with the external field. The sample transmission is normalized to the background, which fluctuates due to microwave components in the experimental setup. Overlaying simulation generated with Easyspin [6], we see that the measured spectrum exhibits a clear signature of the quadrupole interaction, which cannot be explained with Zeeman and hyperfine terms alone. The elements of the Q tensor can, therefore, be reconstructed while correcting the published hyperfine tensor. This, in turn, allows us to identify the ZEFOZ points more accurately.

Upon driving the transitions into saturation, we can measure the relaxation times as the saturation recovers to thermal equilibrium. The lifetimes of the spin states amount from several seconds to minutes, as shown in Fig. 2. Possible explanations for the multi-exponential decay relate to the complex level structure of the system. Apart from a direct transition, the relaxation may involve intermediate states with diverse lifetimes.

In essence, broadband electron spin resonance spectroscopy based on coplanar waveguides is a powerful technique to investigate various materials in the microwave regime, due to the simplicity of installation and robustness of the technique. This way, we characterized the spin Hamiltonian parameters of $\text{Er} : \text{CaWO}_4$. Likewise, we were able to map out the level structure of various rare-earth impurities (Yb, Nd, Ho) in other host materials. Specifically, it was shown that the quadrupole moment of ^{167}Er has a non-negligible impact also in the $^7\text{LiYF}_4$ crystal [7]. Understanding the system under investigation in detail is a key step on the path toward coherent control of the spins. Moreover, the established experimental techniques allow addressing ZEFOZ points of the hyperfine transitions, which is fundamental for the implementation of hybrid systems with spin-based storage in rare-earth ions.

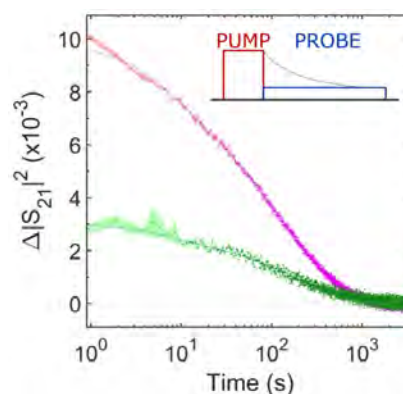

Figure 2: Saturation recovery reveals long lifetimes of the hyperfine states. The relaxation is fitted (blue solid line) to a sum of three exponential functions to account for various decay channels involving intermediate states. (Magenta) 2.65361 GHz transition with lifetimes $\tau_1 = 8.2\text{ s}$, $\tau_2 = 74\text{ s}$, $\tau_3 = 335\text{ s}$. (Green) 3.02655 GHz transition with lifetimes $\tau_1 = 7.9\text{ s}$, $\tau_2 = 125\text{ s}$, $\tau_3 = 711\text{ s}$.

References

- [1] E. Gouzien, and N. Sangouard, *Phys. Rev. Lett.* **127** (2021).
- [2] P. Jobez, N. Timoney, C. Laplane, J. Etesse, A. Ferrier, P. Goldner, N. Gisin, and M. Afzelius, *Phys. Rev. A* **93** (2016).
- [3] M. Zhong, M. P. Hedges, R. L. Ahlefeldt, J. G. Bartholomew, S. E. Beavan, S. M. Wittig, J. J. Longdell, and M. J. Sellars, *Nature* **517** (2015).
- [4] J. Rochman, T. Xie, J. G. Bartholomew, K. C. Schwab, and A. Faraon, *Nature Communications* **14** (2023).
- [5] B. G. Enrique, *The Journal of Chemical Physics* **55** (1971).
- [6] S. Stoll, and A. Schweiger, *Journal of Magnetic Resonance* **178** (2006).
- [7] A. Strinic, P. Oehrl, A. Marx, P. A. Bushev, H. Huebl, R. Gross, and N. Kukharchyk (in preparation).

Electronic System of the Spin-Liquid Candidate κ -(BEDT-TTF)₂Cu₂(CN)₃ on the Verge of the Metal-Insulator Transition

S. Erkenov, W. Biberacher, R. Gross, M.V. Kartsovnik¹
I. Sheikin,² T. Helm³

Despite numerous theoretical studies of ‘bad’ metals near the Mott-insulating transition (MIT), several key predictions still lack experimental verification. A particularly important and unresolved question is how electronic correlations evolve and influence system properties as the Mott state is approached at high correlation strength U/t . One significant hindrance to understanding this is the presence of magnetic interactions, which are expected to shift the MIT to lower critical values of electronic correlation strength (i.e., lower U/t). To minimize the influence of magnetic instability, we investigate the behavior of the effective mass in the quasi-2D, bandwidth-controlled Mott insulator κ -(BEDT-TTF)₂Cu₂(CN)₃ (abbreviated as κ -CN). This compound remains nonmagnetic in the insulating state, making it particularly interesting as a candidate for a quantum spin-liquid material [1], and can be driven into a metallic ground state with the application of moderate pressure, around 0.15 GPa, as seen on phase diagram Fig.1.

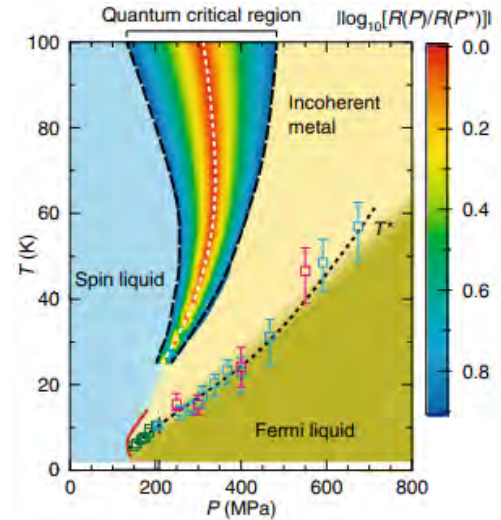

Figure 1: Phase diagram of κ -CN from [1].

We measured the angle-dependent magnetoresistance oscillations (AMRO) of κ -CN samples at fields of 15 T and 26 T [see Fig. 2(a)], with the first AMRO peak occurring near $\theta = 25^\circ$. The AMRO peaks emerge at the field directions, at which the cyclotron orbit areas are independent on the orbit position on the weakly warped Fermi cylinder [2]. These directions are determined by the in-plane Fermi surface geometry. The inset in Fig.2(a) (black dots) shows the inplane FS determined from our AMRO data. The FS gives rise to two fundamental magnetic-oscillation frequencies: the first one corresponds to closed α orbits [Fig. 2(a) inset, indicated by red points, $F_\alpha \approx 800$ T], and the second corresponds to the magnetic- breakdown β orbit, which encompasses the entire FS ($F_\beta \approx 3700$ T). The ratio between the α and β frequencies provides an estimate of the FS shape and the frustration ratio t'/t based on a simple tight-binding model [3] [Fig. 2(a) inset, blue and red points].

The primary challenges in measuring Shubnikov–de Haas (SdH) oscillations in this material are the small oscillation amplitude, as compared to other κ -salts, and its low residual resistance in the metallic state (≈ 10 m Ω). However, these difficulties can be mitigated at the AMRO peaks, where the magnetoresistance increases almost by an order of magnitude, and the amplitude of oscillations also rises significantly [2]. For this reason, we measured SdH oscillations at orientations near the first AMRO peak. In fact, the absolute amplitude of SdH oscillations was increased by more than 10 times at these orientations, see Fig. 2(b).

Extrapolation of the frustration ratio from the oscillation frequencies at different pressures yields $t'/t \approx 1.0$ at ambient pressure, that closely aligns with the value calculated by the extended Hückel method [4]. This value is significantly higher than those reported

¹The work was supported in part by the German Research Foundation, project KA 1652/5-1 and GR 1132/19-1

²Laboratoire National des Champs Magnétiques Intenses LNCMI, CNRS, UPR 3228, F-38042 Grenoble, France

³Helmholtz Zentrum Dresden Rossendorf, Hochfeld Magnetlabor Dresden HLD, 01328 Dresden, Germany

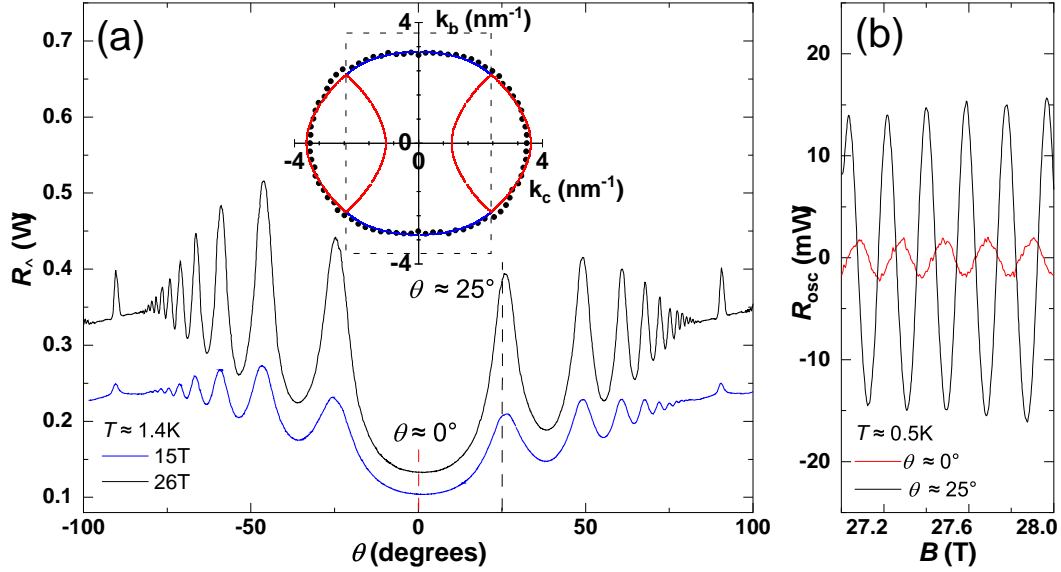

Figure 2: (a) AMRO in κ -CN at pressure 0.24 GPa. Inset: the 2D FS determined from the AMRO (black dots) and calculated from the SdH frequencies within the effective dimer model (red and blue). Dashed lines represent the Brillouin zone boundaries. (b) Example of the SdH oscillations at different orientations and pressure 0.24 GPa.

for the previously studied salts κ -(BEDT-TTF)₂Cu[N(CN)₂]Cl (abbreviated as κ -Cl) and κ -(BEDT-TTF)₂Cu(NCS)₂ (abbreviated as κ -NCS) [3] and it favors the spin-liquid scenario for the ground state in κ -CN. To evaluate the correlation strength, we measured the pressure-dependent effective cyclotron mass $m_c(p)$ renormalized by electron interactions. It can be fitted with the Brickman-Rice formula adaptation [3]: $m_c = m_{\text{band}}[1 - \frac{1}{[1+\gamma(p-p_0)]^2}]^{-1}$.

A fit of experimental data gives the critical pressure $p_0 = (-0.160 \pm 0.003)$ GPa that is about 0.12 GPa higher than in κ -Cl and κ -NCS [3]. We consider this difference as a signature of the “chemical pressure” effect. The saturation value for the effective mass $m_{c,\beta,\text{band}} = (2.8 \pm 0.3)m_0$ is consistent with the calculated band mass value $m_c = 3.1m_0$ [5]. The proportionality coefficient $\gamma = (0.8 \pm 0.2)$ GPa⁻¹ is close to that reported for κ -Cl and κ -NCS [3]. The quasi-particle residue in the vicinity MIT in κ -CN ($Z = \frac{m_{c,\text{band}}}{m_c} \approx 0.32$) is slightly smaller than in κ -Cl and κ -NCS ($Z \approx 0.35$) [3]. This suggests that frustration slightly shifts the MIT to a lower Z .

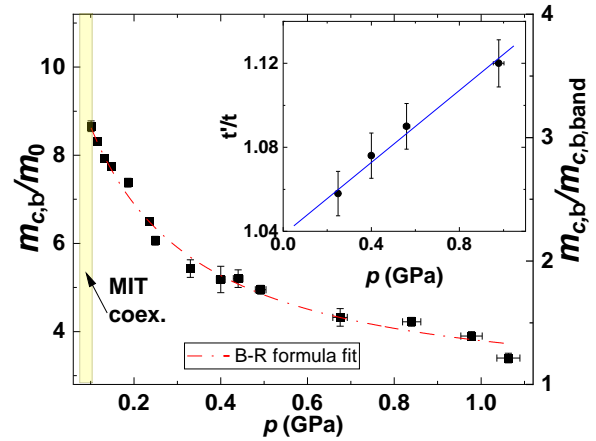
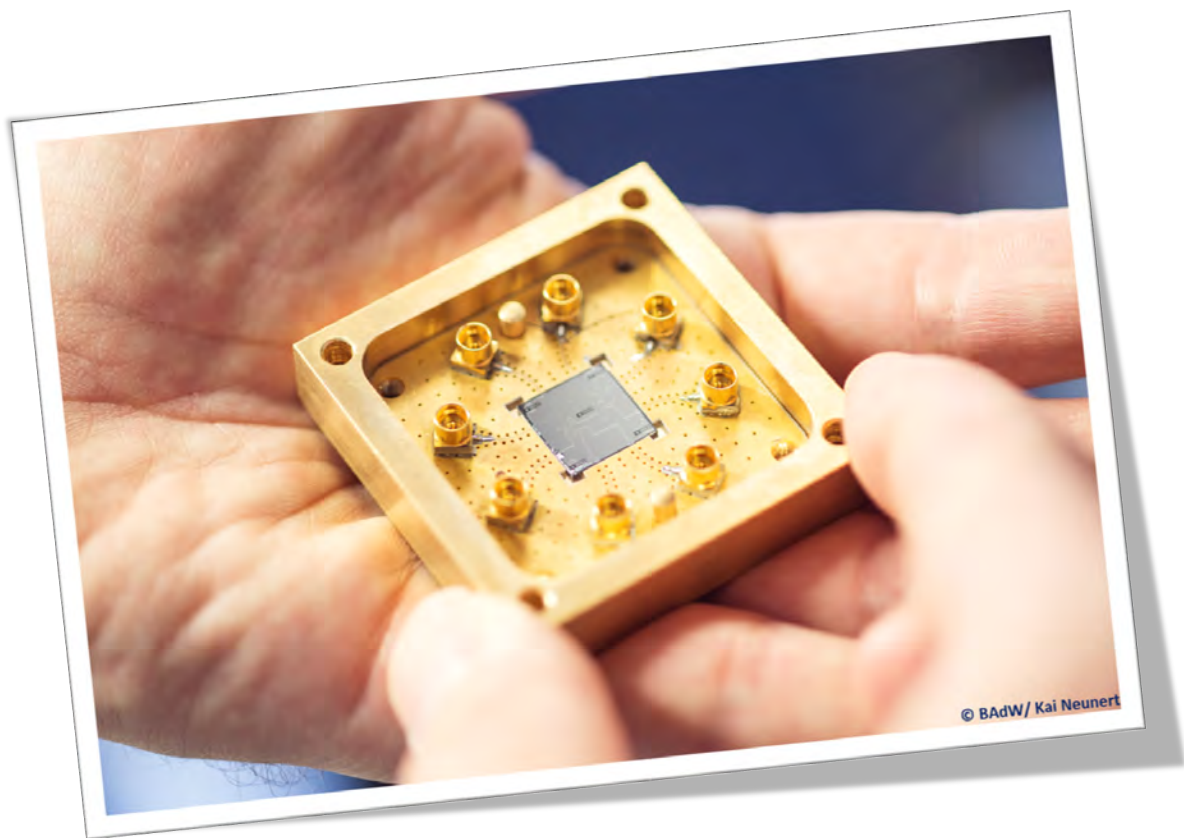

Figure 3: Pressure-dependent cyclotron mass (main panel) and frustration ratio (inset) in κ -CN.

References

- [1] T. Furukawa, K. Kobashi, Y. Kurosaki, K. Miyagawa, and K. Kanoda, *Nat. Comm.* **9**, 307 (2018).
- [2] M. Kartsovnik, *Chem. Rev.* **11**, 57337 (2004).
- [3] S. Erkenov, S. Fust, S. Oberbauer, W. Biberacher, N. D. Kushch, H. Muller, F. L. Pratt, R. Gross, and M. V. Kartsovnik, *Phys. Rev. B* **in press** (2024).
- [4] J. Merino, and R. McKenzie, *Phys. Rev. B* **62**, 2416 (2000).
- [5] T. Komatsu, N. Matsukawa, T. Inoue, and G. Saito, *J. Phys. Soc. Jpn.* **65**, 1340 (1996).

Application-Oriented Research



Thermal Entanglement Distribution

*J. Agusti, C. M. F. Schneider, K. G. Fedorov, S. Filipp, P. Rabl*¹

Quantum networks play an important role in scaling up quantum technologies by facilitating the exchange of quantum states and entanglement between otherwise separated quantum processing or memory units. For such applications, residual thermal excitations in the connecting quantum channels are considered detrimental, since they spoil the transmitted quantum state or lead to false counts in heralded entanglement distribution schemes. Therefore, thermal noise at the relevant communication frequencies must be avoided. In the optical regime, this is usually not a problem, but this requirement imposes considerable cooling efforts for superconducting or phononic quantum networks [1], which are operated at much lower frequencies.

In this theory project, we propose and analyze an alternative strategy by showing that, instead of avoiding it, thermal noise can be turned into a useful resource for quantum communication applications. In the considered setup depicted in Fig. 1, two spatially separated qubits are connected via a coherent quantum channel, which is driven by a purely thermal source of photons or phonons. The driving field is thus completely incoherent and characterized by a largely fluctuating amplitude and phase. Therefore, no coherence or entanglement is expected when the qubits are coupled to such a thermal reservoir. Surprisingly, when the bandwidth of the thermal source becomes sufficiently narrow, i.e., the reservoir becomes highly non-Markovian, a finite amount of entanglement emerges in the steady state of the two qubits, ρ_q . This steady-state entanglement can be systematically increased by further reducing the bandwidth of the source while increasing its temperature.

In our theoretical analysis we explain the emergence of entanglement in this scenario and show that for a vanishing bandwidth, $\kappa \rightarrow 0$, but keeping a constant photon flux $\Phi = \kappa n_{\text{th}}/2$, the steady state of the qubit system is given by

$$\rho_q = Y(\Phi/\gamma)|00\rangle\langle 00| + [1 - Y(\Phi/\gamma)]|S\rangle\langle S|, \quad (1)$$

where γ is the decay rate of the qubits and $Y(x) = e^{1/(8x)}\Gamma[0, 1/(8x)]/(8x)$, with $\Gamma[0, x]$ denoting the incomplete gamma function. In this expression, $|S\rangle = (|10\rangle - |01\rangle)/\sqrt{2}$ is the maximally entangled singlet state, which is reached in this idealized limit when $\Phi/\gamma \gg 1$. In Fig. 2 (a), this result is represented by the dashed lines and compared to exact numerical simulations (solid lines). Interestingly, this comparison shows that while entanglement is initially enhanced by higher levels of thermal noise, it reduces again beyond a characteristic thermal occupation number $n_{\text{th}}^* \propto (\gamma/\kappa)^2$, which is indicated by the vertical dotted lines. For these

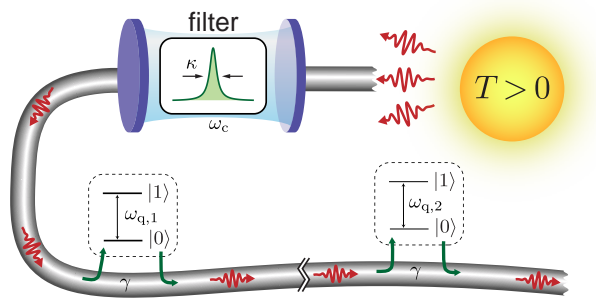

Figure 1: Sketch of the setup considered for entangling two qubits with a non-Markovian thermal source. Here, the source emits incoherent radiation at a high temperature T , which is successively filtered and drives two or multiple qubits along the waveguide. Under resonance conditions, $\omega_{q,1} = \omega_{q,2} \simeq \omega_c$, and when the bandwidth κ of the source is sufficiently small, the qubits relax into a stationary state with a finite amount of entanglement. The amount of entanglement can be systematically increased by raising the temperature T of the source, while reducing its bandwidth.

¹This research is part of the Munich Quantum Valley, which is supported by the Bavarian state government with funds from the Hightech Agenda Bayern Plus.

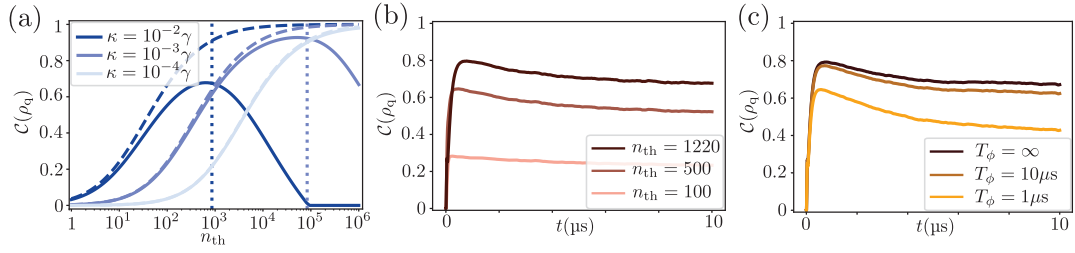

Figure 2: (a) Plot of the steady-state entanglement (expressed in terms of the concurrence \mathcal{C}) between the two qubits as a function of the number of thermal photons of the source and for different cavity bandwidths κ/γ . Time evolution of the entanglement under realistic experimental parameters (see main text) for (b) different thermal occupation numbers and (c) at room temperature for different dephasing times T_ϕ .

numerical simulations, we have mapped the stochastic master equation of this system onto a matrix continued fraction, which allowed us to address the required regime of very larger thermal photon numbers and to obtain approximate analytic expressions for the optimal occupation number n_{th}^* .

To evaluate potential experimental demonstrations of this effect, we have investigated the implementation of this setup with superconducting qubits that are coupled to a common microwave waveguide. In this case, Johnson-Nyquist noise from a resistor at room temperature can be filtered and used as a narrow-band noise source. For our analysis we assume a qubit decay rate into the waveguide of about $\gamma/(2\pi) = 10$ MHz, as demonstrated in related experimental works [2]. A filter bandwidth of $\kappa/(2\pi) < 100$ kHz can be achieved with a microwave resonator with a reasonable quality factor of about $Q \sim 10^5$. For these parameters, Fig. 2 (b) and (c), show the build up of entanglement for different temperatures of the source. In particular, for a room temperature source with $T = 300$ K, which at microwave frequency of $\omega_c/(2\pi) = 5$ GHz corresponds to $n_{th} \simeq 1200$, we predict a substantial amount of entanglement in the steady state, which also survives when considering a finite dephasing rate $\gamma_\phi = 1/T_\phi$ for each qubit.

In summary, this project shows how an incoherent thermal reservoir can be used as a resource to generate entanglement between separated qubits, fully autonomously and without any additional pulse control. This is of interest from a conceptual as well as from a practical point of view and we have evaluated possible implementations in the context of superconducting qubits. The investigated setups are inspired by the existing experimental setups at WMI, where this scheme could be tested with superconducting qubits on the same chip, as well as with qubits that are many meters apart [3].

References

- [1] Z.-L. Xiang, M. Zhang, L. Jiang, and P. Rabl, *Phys. Rev. X* **7**, 011035 (2017).
- [2] P. S. Shah, F. Yang, C. Joshi, and M. Mirhosseini, *PRX Quantum* **5**, 030346 (2024).
- [3] W. K. Yam, M. Renger, S. Gandorfer, F. F. and M. Handschuh, K. E. Honasoge, F. Kronowetter, Y. Nojiri, M. Partanen, M. Pfeiffer, H. van der Vliet, A. J. Matthews, J. Govenius, R. N. Jabdaraghi, M. Prunnila, A. Marx, F. Deppe, R. Gross, and K. G. Fedorov. Cryogenic microwave link for quantum local area networks. [arXiv:2308.12398](https://arxiv.org/abs/2308.12398) (2023).

Towards Microwave Hybrid Entanglement

*S. Gandorfer, M. Handschuh, J. Agustí, K. E. Honasoge, P. Rabl, R. Gross, K. G. Fedorov*¹

Distributing entanglement between spatially separated nodes of a large-scale quantum network is a fundamentally important milestone for many applications. It provides the quantum resource for various quantum communication protocols, such as quantum teleportation or remote qubit gates. In this context, we aim to experimentally investigate entanglement between static, discrete-variable (DV), superconducting qubits and propagating, continuous-variable (CV), microwave signals. A schematic illustration of our experimental setup is shown in Fig. 1. We employ a pair of Josephson parametric amplifiers (JPAs) for the generation of squeezed microwave states. These squeezed states are superimposed using a microwave hybrid ring, forming an entangled, propagating two-mode squeezed (TMS) state at the hybrid ring outputs [1]. The TMS modes are distributed via weakly lossy channels. One of these channels couples to the DV, cavity-qubit, system, while another is directly connected to the setup output. This DV system consists of a 3D niobium-aluminum transmon qubit, being resonant with the frequency of the TMS state. In order to enhance the interaction between the transmon and the TMS local mode, we place the qubit inside a resonant superconducting 3D aluminum cavity. Due to the interaction, the qubit and cavity subsystems hybridize and form two dressed states, visible as a narrow resonant response at low drive powers in Fig. 2(a). The corresponding quantum state is also known as a quantum polariton state and can be used to study hybrid entanglement by illuminating it with a resonant TMS radiation.

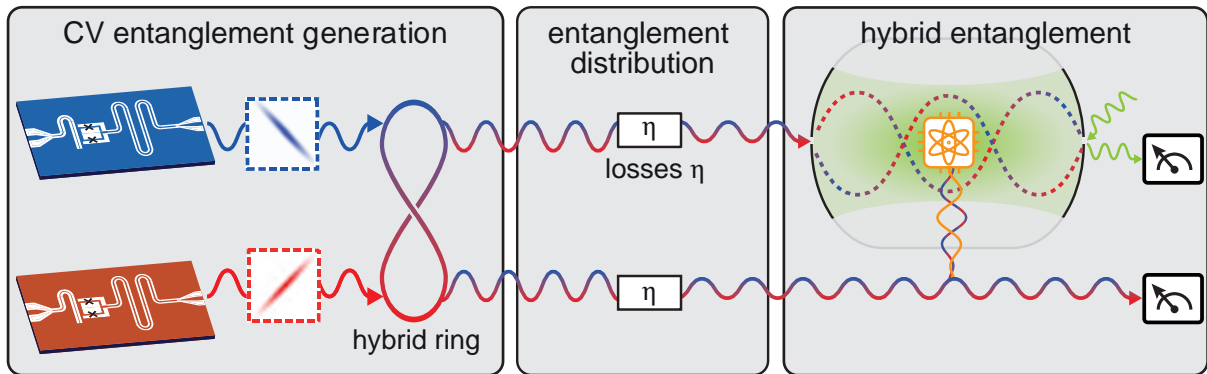

Figure 1: Schematic illustration of the hybrid entanglement protocol. A pair of JPAs is used to generate the propagating TMS states, which act as a quantum-correlated reservoir. A superconducting transmon qubit inside a 3D cavity is then resonantly driven by one of the TMS state modes.

In order to investigate quantum entanglement between two arbitrary quantum subsystems, one needs to use one out of many existing entanglement monotones or measures. However, this approach typically requires knowledge of a full density matrix of the entire system, making it difficult to obtain in an experiment. To circumvent this issue, we introduce an appropriate entanglement witness \mathcal{W} . If one assumes a set of n non-commuting observables $\{A\}_{i=1}^n$ and $\{B\}_{i=1}^n$ for each subsystem, then the sum of their variances is always bounded from below for any state $\sum_{i=1}^n (\Delta A_i)^2 \geq U_A$ and $\sum_{i=1}^n (\Delta B_i)^2 \geq U_B$, where $U_{A,B} > 0$. By defining a joint measurement $M = A_i \otimes I + I \otimes B_i$, we can find that the inequality $\sum_{i=1}^n (\Delta M_i)^2 \geq U_A + U_B$ holds for any separable state [2]. Its violation implies the presence of quantum entanglement. For our specific situation, a suitable set of observables are electromagnetic field quadrature

¹We acknowledge support by the German Research Foundation via Germany's Excellence Strategy (EXC-2111-390814868), the German Federal Ministry of Education and Research via the project QUARATE (Grant No. 13N15380). This research is part of the Munich Quantum Valley, which is supported by the Bavarian state government with funds from the Hightech Agenda Bayern Plus.

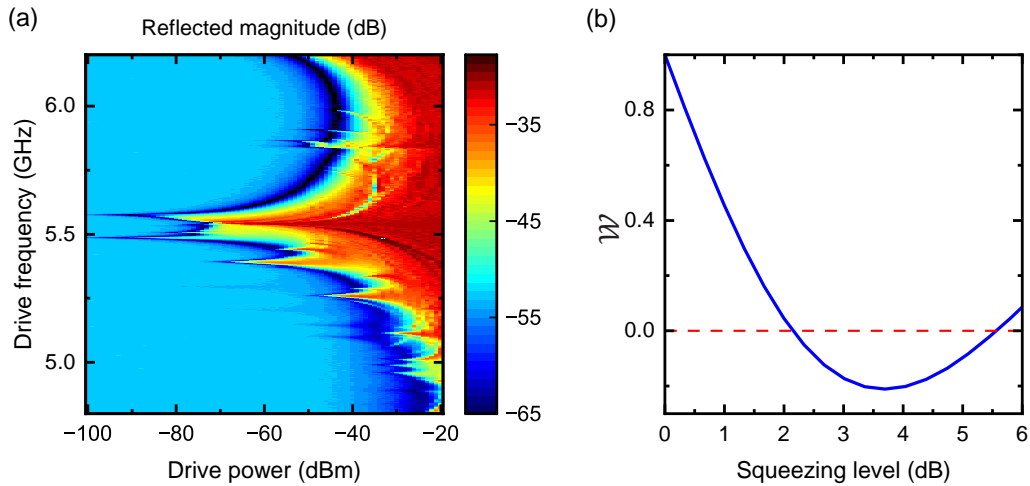

Figure 2: (a) Two-tone spectroscopy measurement as a function of the drive power of the coupled qubit-cavity system. Two narrow resonant responses at the frequencies of $f_1 = 5.48$ GHz and $f_2 = 5.57$ GHz represent a quantum polariton state, which can be used for entangling it with the TMS state. (b) Numerical simulation of the entanglement witness \mathcal{W} between the qubit and the propagating TMS state as a function of the squeezing level for typical experimental parameters.

operators, \hat{p} and \hat{q} , as well as the Pauli operators, $\hat{\sigma}_y$ and $\hat{\sigma}_z$, describing the qubit state. Using these operators, one can show that for any separable state the inequality

$$\mathcal{W} = \text{Var}(\hat{\sigma}_y + \hat{p}) + \text{Var}(\hat{\sigma}_z - \hat{q}) - 2 \geq 0 \quad (1)$$

must hold. Therefore, a negative witness \mathcal{W} demonstrates the presence of quantum entanglement. Figure 2(b) shows a numerical simulation of the witness \mathcal{W} as a function of the squeezing of the TMS state for our typical experimental parameters. Here, we observe that the polariton becomes optimally entangled with the resonant propagating microwave states for the squeezing levels around 3 dB below vacuum.

In conclusion, we have presented our experimental progress toward hybrid entanglement between continuous and discrete degrees of freedom. Our preliminary measurements indicate that such entanglement is within the reach of experimentally accessible parameters. Finally, the discussed protocol can be extended to the entanglement of remote superconducting qubits and would contribute to the ongoing development of quantum networks and distributed quantum computing.

References

- [1] K. G. Fedorov, S. Pogorzalek, U. Las Heras, M. Sanz, P. Yard, P. Eder, M. Fischer, J. Goetz, E. Xie, K. Inomata, Y. Nakamura, R. Di Candia, E. Solano, A. Marx, F. Deppe, and R. Gross, *Scientific Reports* **8**, 6416 (2018).
- [2] O. Gühne, and G. Tóth, *Physics Reports* **474**, 1–75 (2009).

Microwave Entanglement Distribution over Thermal Communication Channels

W. K. Yam, S. Gandorfer, F. Fesquet, K. Honasoge, M. Handschuh, A. Marx, R. Gross, K. G. Fedorov¹

Quantum information processing is expected to advance from individual processor units to networks of interconnected nodes in the near future. One of the leading platforms for quantum information processing is superconducting quantum circuits, which operate in the microwave frequency range. These superconducting circuits, typically, must be cooled to millikelvin temperatures in order to enable superconductivity and suppress the microwave thermal noise. Here, we experimentally study how elevated temperatures affect microwave quantum states and the propagation of entanglement through thermal channels. In our experiments, we rely on a prototype microwave quantum local area network (QLAN) based on two dilution cryostats connected via a cryogenic link (“cryolink”). The cryostats are spatially separated by 6.6 m and the cryolink reaches a base temperature of 52 mK at its center [1]. We investigate heat propagation through our prototype QLAN and demonstrate that microwave quantum entanglement can be successfully distributed through a thermal communication channel.

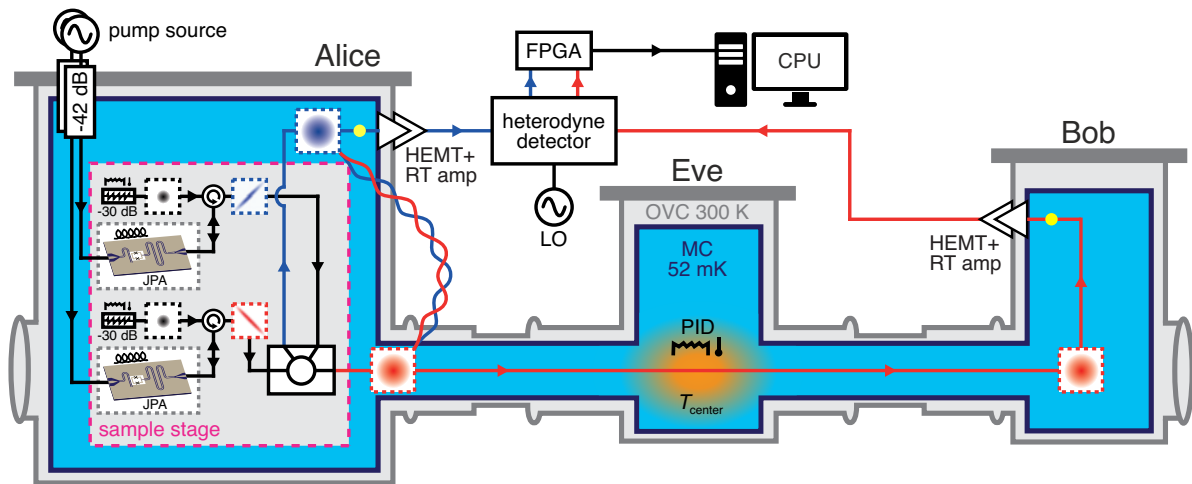

Figure 1: Schematic of our experimental setup for entanglement distribution. Propagating TMS states are generated in Alice. Then, one TMS mode is kept in Alice and another mode is transmitted over the cryolink to Bob. A PID-controlled heater is used to adjust the local temperature T_{center} in the MC tube at Eve.

Our microwave QLAN connects two quantum processor nodes (Alice and Bob) via a cold network node (Eve). The mixing chamber (MC) stages of the Alice and Bob cryostats are connected via a copper MC tube that extends through the cryolink. Inside the MC tube at the cryolink center, we install a PID-controlled heater to elevate its local temperature, T_{center} . A schematic of the corresponding experimental setup is illustrated in Fig. 1. We begin our experimental sequence for entanglement distribution studies by using superconducting Josephson parametric amplifiers (JPAs) for the generation of two orthogonally squeezed vacuum states at the carrier frequency of 5.35 GHz with identical squeezing levels, S . By combining these states at a hybrid ring, we produce an entangled two-mode squeezed (TMS) state. One of these modes is kept in Alice, while the other mode is transmitted over the cryolink to Bob. We per-

¹We acknowledge support by the German Research Foundation via Germany’s Excellence Strategy (EXC-2111-390814868). This research is part of the Munich Quantum Valley, which is supported by the Bavarian state government with funds from the Hightech Agenda Bayern Plus.

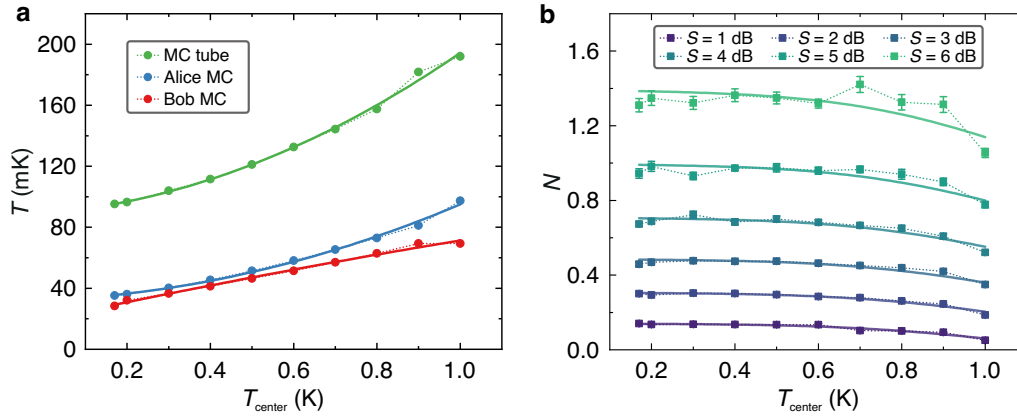

Figure 2: Experimental results. (a) Effect of the cryolink center heating on temperatures of various QLAN components. (b) Negativity, N , of the two-mode, Alice and Bob, state as a function of T_{center} . Positive negativity, $N > 0$ indicates bipartite quantum entanglement (inseparability) of microwave modes.

form a joint measurement of TMS modes in Alice and Bob to determine the amount of shared quantum entanglement. We repeat this procedure for various T_{center} up to 1 K by employing the PID-controlled heater in Eve. We observe that as T_{center} increases, heat propagates from the cryolink center to the Alice and Bob MCs, moderately raising their temperatures. Figure 2(a) shows temperatures of the main QLAN components with respect to T_{center} , where we fit the data with second-order polynomial functions. These results indicate that, for a realistic microwave quantum network, the heat load in the network nodes and communication channels can be tolerated in the wide range of T_{center} by using the existing cryogenic technology.

Furthermore, we study the resilience of our microwave QLAN against elevated temperatures by performing entanglement distribution over a thermal communication channel. Figure 2(b) shows measured entanglement monotone values in the form of negativity, N , of our distributed TMS states as a function of T_{center} , where we fit the data with a theory model. Negativity is the entanglement monotone derived from the Peres-Horodecki criterion for separability and its positive values, $N > 0$, imply bipartite quantum entanglement. We see that N decreases with T_{center} because added thermal noise from the cryolink center reduces the purity of the propagating microwave quantum states. Nonetheless, negativity stays positive, and thus, distributed quantum entanglement survives up to the center temperatures of 1 K. For a TMS state with $S = 6$ dB, we achieve $N = 1.31 \pm 0.04$ at the cryolink base temperature and obtain $N = 1.05 \pm 0.02$ for maximum $T_{\text{center}} = 1$ K. These results indicate that quantum entanglement distribution is feasible even in the presence of strong thermal noise, as long as the inherent channel losses are low.

In conclusion, we have demonstrated the successful distribution of microwave entanglement between macroscopically remote parties using the QLAN prototype. We have found that the temperature of the QLAN channel is not limited by the millikelvin range and can be extended to 1 K and, possibly, even further. These results pave the way towards more practical microwave quantum networks and bring us a step closer to distributed quantum computing with superconducting circuits.

References

- [1] W. K. Yam, M. Renger, S. Gandorfer, F. Fesquet, M. Handschuh, K. E. Honasoge, F. Kronowetter, Y. Nojiri, M. Partanen, M. Pfeiffer, H. van der Vliet, A. J. Matthews, J. Govenius, R. N. Jabdaraghi, M. Prunnila, A. Marx, F. Deppe, R. Gross, and K. G. Fedorov. Cryogenic microwave link for quantum local area networks. [arXiv:2308.12398](https://arxiv.org/abs/2308.12398) (2023).

Machine Learning for Quality Factor Estimation in Superconducting Resonators

K.E. Honasoge, F. Fesquet, R. Gross, K.G. Fedorov¹

Superconducting quantum circuits are essential for quantum computing and communication. They rely on precise resonator fabrication and characterization, allowing one to optimize performance and refine fabrication processes. Conventional methods of determining resonator losses are often limited by noise and experimental artifacts, such as impedance mismatches and phase delays. Recent advancements in machine learning (ML) provide a promising alternative to efficiently handle noisy data and extract parameters from complex systems, enabling streamlined resonator analysis.

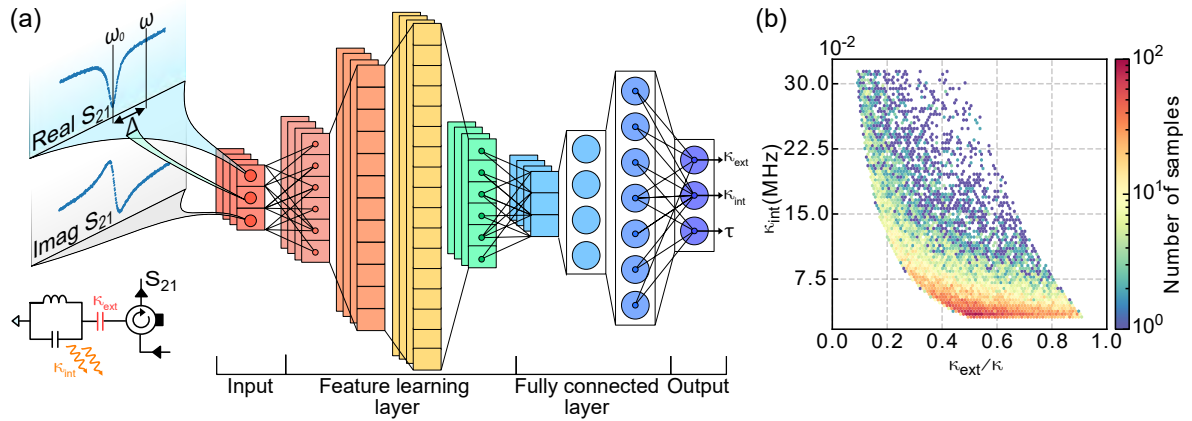

Figure 1: (a) Illustration of KAPPANET, the physics-informed neural network based on six convolutional layers and three fully connected layers. The three inputs to KAPPANET are $\text{Re } S_{21}$, $\text{Im } S_{21}$, and detuning $\Delta = \omega - \omega_0$. Outputs from KAPPANET are the predicted coupling rates κ_{ext} , κ_{int} , and the cable delay τ . (b) Distribution of κ_{int} versus coupling efficiency $\kappa_{\text{ext}}/\kappa$ used for generation of synthetic scattering coefficients in the training dataset. The dataset consists of 20×10^4 noisy resonators with randomly sampled coupling rates κ_{ext} , κ_{int} , and the cable delay τ .

Here, we explore the feasibility of employing machine learning (ML) for the analysis of superconducting resonator measurements. Specifically, we utilize a physics-informed neural network (PINN) labeled KAPPANET that combines a convolutional neural network with fully connected layers illustrated in Fig. 1(a) [1–3]. The ML model is trained and tested on a synthetic scattering reflection dataset corresponding to 2×10^4 different resonators. Each scattering coefficient in the dataset is generated using an input-output theory model. The scattering coefficient S_{21} for each resonator is defined based on its coupling rates, κ_{ext} and κ_{int} , to the input line and environment, respectively. The ideal scattering coefficient S_{21}^{ideal} , measured in reflection from a single port, is expressed as

$$S_{21}^{\text{ideal}} = 1 + \frac{\kappa_{\text{ext}}}{i\Delta - \kappa/2}, \quad (1)$$

where $\Delta = \omega - \omega_0$ is the detuning between the probe frequency and the resonance frequency ω_0 , while $\kappa = \kappa_{\text{ext}} + \kappa_{\text{int}}$ is the total resonator loss rate.

Our complete synthetic dataset consists of κ_{ext} and κ_{int} values randomly sampled over the range from 0.05 to 30 MHz. The corresponding distribution of κ_{int} versus the coupling efficiency $\kappa_{\text{ext}}/\kappa$ is shown in Fig. 1(b). To simulate experimental conditions, random Gaussian

¹We acknowledge support from the German Research Foundation via Germany’s Excellence Strategy (Grant No. EXC-2111-390814868) and the German Federal Ministry of Education and Research via the QUARATE project (Grant No.13N15380). This research is part of the Munich Quantum Valley, which is supported by the Bavarian state government with funds from the Hightech Agenda Bayern Plus.

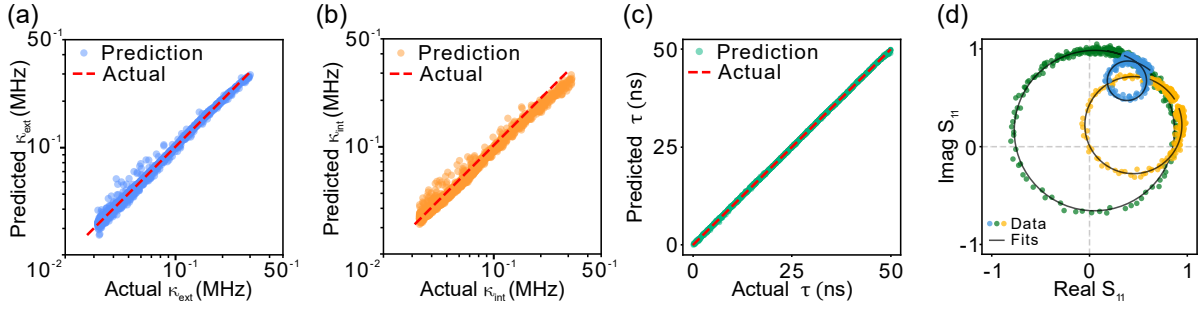

Figure 2: Performance of KAPPANET on test data in predicting parameters (a) κ_{ext} , (b) κ_{int} , and (c) τ . (d) Predictions of KAPPANET fit well to the actual test data over a large range of coupling rates including the overcoupled $\kappa_{\text{ext}} > \kappa_{\text{int}}$ (green), critically coupled $\kappa_{\text{ext}} \sim \kappa_{\text{int}}$ (gold), and undercoupled $\kappa_{\text{ext}} < \kappa_{\text{int}}$ (blue) resonator regimes.

noise (with a standard deviation of 0.02) is added to the scattering coefficients, and the latter is additionally distorted by random cable delays τ in the range between 0 and 50 ns. The dataset is split into 80% training, 10% validation, and 10% test data. The model is trained using a batch size of 64 and the Adam optimizer, with learning rates adjusted dynamically by a scheduler to ensure convergence [4, 5].

The PINN comprises six convolutional layers followed by three fully connected layers. Convolutional layers extract spatial features from the scattering response, while the fully connected layers predict κ_{ext} , κ_{int} , and τ . The integration of physical principles is achieved through a composite loss function

$$\mathcal{L}_{\text{total}} = \mathcal{L}_{\text{data}} + \lambda_{\text{physics}} \mathcal{L}_{\text{physics}} + \lambda_{\text{reg}} \mathcal{L}_{\text{reg}}, \quad (2)$$

where $\mathcal{L}_{\text{data}}$ is a weighted mean squared error between predicted and true parameters, $\mathcal{L}_{\text{physics}}$ penalizes deviations from the theoretical scattering response based on Eq. (1), and \mathcal{L}_{reg} is a L_2 -norm regularization term to prevent overfitting. Weighting factors, λ_{physics} and λ_{reg} , control contributions of the physics-based and regularization losses, respectively.

The PINN demonstrates high predictive accuracy across a broad range of κ_{ext} , κ_{int} , and τ values, including those not encountered during training (see Fig. 2). By embedding physical knowledge into the loss function, the model achieves faster convergence and better generalization, as compared to standard ML approaches. Our framework offers a robust, scalable solution for future experimental resonator characterization routines in the presence of imperfections, paving the way for more efficient development of superconducting circuits for quantum technologies.

References

- [1] R. Wang, and R. Yu. Physics-Guided Deep Learning for Dynamical Systems: A Survey. [arXiv:2107.01272](https://arxiv.org/abs/2107.01272) (2023).
- [2] S. Cuomo, V. S. Di Cola, F. Giampaolo, G. Rozza, M. Raissi, and F. Piccialli, *J Sci Comput* **92**, 88 (2022).
- [3] J. D. Toscano, V. Oommen, A. J. Varghese, Z. Zou, N. A. Daryakenari, C. Wu, and G. E. Karniadakis. From PINNs to PIKANs: Recent Advances in Physics-Informed Machine Learning. [arXiv:2410.13228](https://arxiv.org/abs/2410.13228) (2024).
- [4] D. P. Kingma, and J. Ba. Adam: A Method for Stochastic Optimization. [arXiv:1412.6980](https://arxiv.org/abs/1412.6980) (2017).
- [5] J. T. Ash, C. Zhang, A. Krishnamurthy, J. Langford, and A. Agarwal. Deep Batch Active Learning by Diverse, Uncertain Gradient Lower Bounds. [arXiv:1906.03671](https://arxiv.org/abs/1906.03671) (2020).

Scaling of Superconducting Qubit Architectures: Development and Realization of a 17-Qubit QPU

M. Werninghaus, C.M.F. Schneider, G.B.P. Huber, N.J. Glaser, J.H. Romeiro, S. Schöbe, I. Tsitsilin, J. Schirk, F.A. Roy, L. Koch, N. Bruckmoser, J. Feigl, S. Filipp ¹

In 2024, the Quantum Computing group at the WMI has successfully realized a 17 quantum processing unit (QPU). The scalable transmon architecture is the core of several of the larger projects, and positions WMI to pursue both application-oriented research and scalable error-correction methods. The development roadmap for the processor entails several key performance indicators (KPIs), as listed in Table 1. So far, all KPIs have been achieved individually on dedicated chips, and the ongoing efforts in the next year will focus on demonstrating the combined performance on a single QPU. Full controllability of the device has been demonstrated, including simultaneous interactions and feedback based reset.

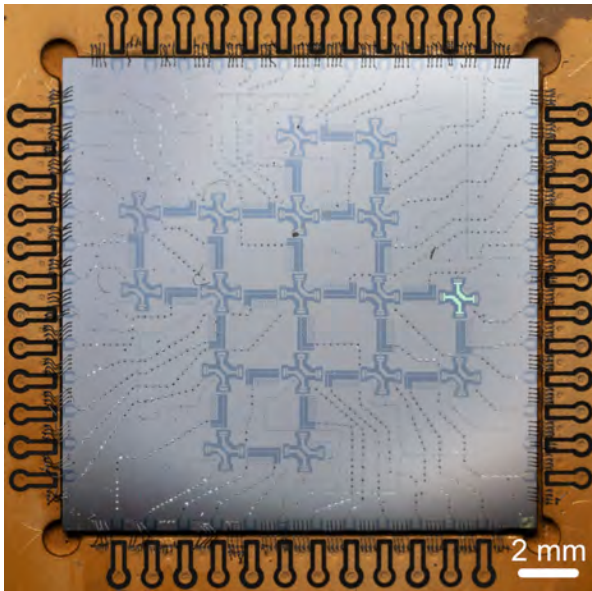

Figure 1: Optical image of a 17-qubit chip with qubits at the corners of rectangular plaquettes connected by tunable couplers. Qubit 11 is highlighted in green.

KPI	17-Q QPU
# Qubits	17
Connectivity	$c \geq 2$
Gate Set	SU(2), CZ
1-Qu. Gate fid.	99.5 ^{+0.2} _{-0.6} %
2-Qu. Gate fid.	97.7 ^{+0.8} _{-2.2} %
Readout fid.	>98 %
T_1 times	60.4 ⁺¹⁰ ₋₁₅ μ s
T_2 times	7.5 ⁺¹² ₋₂ μ s
T_2/t_{gate}	50
Qubit Reprod.	5.2 % avg
Crosstalk	< 3 % avg
Cycle time	0.5 ms

Table 1: Key performance indicators for mid-scale quantum processing units as part of the MUNIQ-SC project, along with the current status of the most recent device under characterization. The T_1 and T_2 times, as well as single- and two-qubit gate fidelities, are median values across the chip with quartiles indicated.

The first prototype of the 17-qubit QPU was fabricated in March 2024 with a layout optimized for surface-code-based error correction [1], as shown in Fig. 1. The design features tunable couplers for mediating interactions, which have been validated in the lab to achieve CZ operation fidelities exceeding 99.9%. Several iterations of the QPU has been fabricated to first verifying wiring, microwave electronics, and cryostat configurations and then focus on optimizing fabrication recipes for larger chips, including an air-bridge-first process to address routing constraints and mitigate parasitic slot-line modes. Qubit coherence times were systematically characterized in each iteration, leading to continuous improvements in QPU design and fabrication. Challenges related to the integration of Josephson junctions with the

¹We acknowledge financial support from the German Federal Ministry of Education and Research via the funding program quantum technologies - from basic research to the market under contract number 13N15680 "GeQCoS" and under contract number 13N16188 "MUNIQ-SC" as well as by the Deutsche Forschungsgemeinschaft (DFG, German Research Foundation) via project number FI2549/1-1 and the Germany's Excellence Strategy EXC-2111-390814868 'MCQST', as well as the Horizon Europe programme HORIZON-CL4-2022-QUANTUM-01-SGA via the project 101113946 (OpenSuperQPlus100). The research is part of the Munich Quantum Valley, which is supported by the Bavarian state government with funds from the Hightech Agenda Bayern Plus.

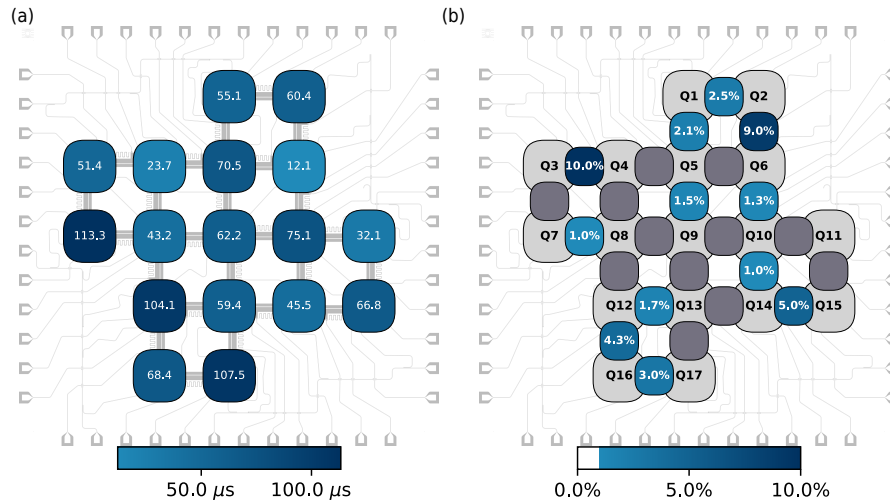

Figure 2: Measured properties of the latest iteration of the 17-qubit chip schematically displayed over the chip topology. a) T1 Lifetime of individual qubits and b) fidelity of calibrated two-qubit gates.

air-bridge-first process were resolved through refined fabrication steps.

From the fifth generation onward, fabrication has been stable, achieving a survival rate near 100%. Initial failures were attributed to discharges of the needle-prober. Despite systematic variations across iteration due to fabrication refinements, frequency variation across single chips has been exceedingly well, with a spread of $4.6\% \pm 2.6\%$ (calculated as standard deviation normalized to the arithmetic mean) across all generations. This includes also the parameters of devices characterized only at room temperature, which have been derived via the Ambegaokar-Baratoff relation [2]. The fabrication stability has enabled precise tuning of qubit parameters for optimized readout, qubit-qubit interactions, and control line routing, accelerating the progress toward a fully operational QPU. Additional steps such as laser annealing are currently under investigation to improve the frequency targeting overall [3].

Currently the fifteenth iteration of the 17-qubit prototype is under investigation with the KPIs listed in Table 1 and individual lifetimes and two qubit gate fidelities presented in Fig. 2. The current task is to improve the coherence times of qubits to the established standard achieved on single qubit samples. Fabrication recipes and design optimizations are now being fine-tuned using smaller chips built from unit cells of the larger architecture. This approach aims to enhance the stability of fabrication processes, improves consistency across experimental systems, and enables the WMI to reliably produce custom experimental systems with deterministic designs with faster turnaround times.

References

- [1] S. Krinner, N. Lacroix, A. Remm, A. Di Paolo, E. Genois, C. Leroux, C. Hellings, S. Lazar, F. Swiadek, J. Herrmann, G. J. Norris, C. Kraglund Andersen, M. Müller, A. Blais, C. Eichler, and A. Wallraff, *Nature* **605**, 669–674 (2022).
- [2] V. Ambegaokar, and A. Baratoff, *Physical review letters* **10**, 486 (1963).
- [3] J. B. Hertzberg, E. J. Zhang, S. Rosenblatt, E. Magesan, J. A. Smolin, J.-B. Yau, V. P. Adiga, M. Sandberg, M. Brink, J. M. Chow et al., *npj Quantum Information* **7**, 129 (2021).

Extending Remote Access to Multiple Quantum Processors

*M. Knudsen, N. Glaser, J. Romeiro, M. Singh, G. Krylov, M. Werninghaus, S. Filipp*¹

This year, the main focus of the cloud-access effort of the WMI has been on extending the existing framework while adding more front ends and integrating more chips into the cloud. Due to a maturation of the cloud setup architecture, integration of new experimental systems can now be achieved in a few hours. Monitoring and controlling of cloud access to each integrated setup can now be performed by a WMI internal dashboard, streamlining the sharing of resources between cloud and lab. Lastly, cloud access has been integrated into the broader Munich Quantum Valley Software Stack (MQSS), enabling users to benefit from advanced compilation and HPC integration features.

Integration into Munich Quantum Software Stack

MQSS [1] is a coherent quantum computing software stack that allow users to send experiments to various quantum computers while utilizing advanced compilation and high-performance computing (HPC) integration. The WMI cloud interface has been integrated into the broader MQSS infrastructure via the C/C++ based Quantum Device Management Interface (QDMI) [2]. A QDMI backend has been implemented with required logic to send experiments over the internet to the web-api at the WMI and query the resulting measurement outcomes. In order to allow testing of interfaces while the hardware is occupied, a dedicated Qiskit Aer simulator was set up at the WMI. Since MQSS uses Quantum Intermediate Representation (QIR) [3], part of the integration effort has been to make the WMI web api accept and convert QIR into the native qobj format [4] used by the proprietary experimental control software. Lastly, qubit quality parameters, such as T₁-time, T₂-time and fidelities of each qubit are now query-able, which can inform transpilation for optimized fidelity of the submitted quantum circuit.



Figure 1: Cloud status dashboard allowing WMI quantum computing researchers to control remote access to their chips, preventing corruption of local experiments.

Cloud Status Dashboard

Previous testing cycles with the remote access platform have shown, that centralized access management is crucial. Unintentional simultaneous cloud and lab access can disturb measurements and lead to faulty experimental results. Therefore, a cloud status access control dashboard was created, see Fig. 1. This dashboard enables admins to control cloud access to their devices and allows all within the WMI LAN to view the current cloud status of the available setups. The value in the dashboard sets the current value in a database that the cloud webserver queries before running experiments.

Queues

In order to allow serialized execution of simultaneous experiments from different clients, a scheduling system tracking the requests is necessary. This is solved currently through an in-memory Redis [5] task queue for each setup. Using the Python package rq-dashboard [6],

¹We acknowledge financial support from the German Federal Ministry of Education and Research via the funding program quantum technologies - from basic research to the market under contract number 13N15680 "GeQCoS" and under contract number 13N16188 "MUNIQC-SC" as well as by the Deutsche Forschungsgemeinschaft (DFG, German Research Foundation) via project number FI2549/1-1 and the Germany's Excellence Strategy EXC-2111-390814868 'MCQST'. The research is part of the Munich Quantum Valley, which is supported by the Bavarian state government with funds from the Hightech Agenda Bayern Plus.

Queue	Queued jobs	Deferred jobs	Scheduled jobs	Started jobs	Finished jobs	Failed jobs	Canceled jobs
6q	0	0	0	0	0	0	0
dedicated	7	0	0	1	3	0	0

Figure 2: Status dashboard showing the status of Redis task queues for each quantum processor. This is integrated into the cloud dashboard in Fig 1 and allows monitoring current jobs including error trace-backs useful for debugging.

viewing current jobs and controlling each queue is possible via the cloud-status dashboard, see Fig. 2.

Beta Testing

Since all fundamental components of the cloud interface have been implemented, the primary objective is now to evaluate its functionality using real-world algorithms and identify any gaps that must be addressed to enhance its utility. Currently, the WMI is collaborating with the German Space Agency (DLR) to run a two-qubit algorithms (Qgrape) through the cloud and will engage in similar beta testing with other stakeholders including LMU, LRZ, Juelich, ParityQC and various TUM chairs. Since its inception, the cloud interface has successfully processed more than 520000 jobs. This includes approximately 2300 jobs that have successfully run on actual hardware whereas the rest are mostly simulation-jobs.

Hardware Vendors Direct Access to Hardware

In pilot project for the direct access to WMI-fabricated quantum hardware, Zurich Instruments has set up a room-temperature control setup to directly control a qubit sample at the WMI. At this setup, the WMI and Zurich Instruments are developing joint projects of which the implementation work lies with Zurich Instruments, to allow for a seamless testing pipeline. Zurich Instruments has further been using the quantum chip to demonstrate the features of their control platform independently.

Advanced Features

Finally, the WMI is currently extending the cloud interface with several advanced features: Error mitigation methods to improve accuracy of results, hybrid experiments architecture for variational algorithms, arbitrary pulse shapes for qubit gates and cloud triggered calibration.

References

- [1] M. Schulz, L. Schulz, M. Rufenacht, and R. Wille. Towards the Munich Quantum Software Stack: Enabling Efficient Access and Tool Support for Quantum Computers. In **2023 IEEE International Conference on Quantum Computing and Engineering (QCE)**, Vol. 02399–400 (2023).
- [2] R. Wille, L. Schmid, Y. Stade, J. Echavarria, M. Schulz, L. Schulz, and L. Burgholzer. QDMI – Quantum Device Management Interface: A Standardized Interface for Quantum Computing Platforms. In **2024 IEEE International Conference on Quantum Computing and Engineering (QCE)**, (2024). To appear.
- [3] QIR Alliance: <https://qir-alliance.org>. QIR Specification.
- [4] D. C. McKay, T. Alexander, L. Bello, M. J. Biercuk, L. Bishop, J. Chen, J. M. Chow, A. D. Córcoles, D. Egger, S. Filipp, J. Gomez, M. Hush, A. Javadi-Abhari, D. Moreda, P. Nation, B. Paulovicks, E. Winston, C. J. Wood, J. Wootton, and J. M. Gambetta. Qiskit Backend Specifications for OpenQASM and OpenPulse Experiments. [arXiv:1809.03452 \[quant-ph\]](https://arxiv.org/abs/1809.03452) (2018).
- [5] V. Driessen, and R. Contributors. RQ (Redis Queue): Simple Job Queues for Python. <https://github.com/rq/rq>. Accessed: November 5, 2024 (2024).
- [6] R. Contributors. RQ Dashboard. <https://github.com/rq/rq-dashboard>. Accessed: November 5, 2024 (2024).

Impedance-Matched Broadband Josephson Parametric Amplifier

M. Handschuh, D. Contreras, K. E. Honasoge, D. Bazulin, N. Bruckmoser, L. Koch, A. Marx, R. Gross, K. G. Fedorov¹

Josephson parametric amplifiers (JPAs) have become integral experiments with superconducting quantum circuits due to their near quantum-limited performance. However, traditional JPAs suffer from narrow bandwidths and limited compression powers, posing challenges for applications that require a broad frequency range and relatively large signal powers. In this context, we discuss the design and architecture of a broadband JPA, incorporating an on-chip impedance-matching circuit based on two coupled resonators. We present corresponding gain measurement results which demonstrate spectral bandwidth improvement by two orders of magnitude over conventional superconducting parametric amplifiers.

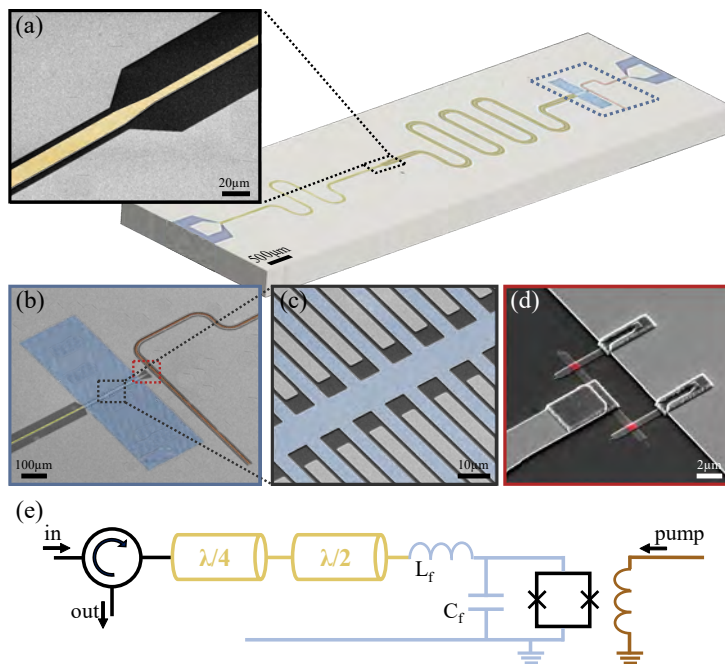

Figure 1: Design layout of the broadband JPA. Colored boxes show close-ups of central elements of the broadband JPA: (a) SEM image of the connection between the $\lambda/4$ and $\lambda/2$ CPW resonators. (b) The dc-SQUID area with shunting fish-bone capacitors and a pump line. (c) Detailed view of the fish-bone array geometry. (d) SEM image of the dc-SQUID, with the Al strips forming the Al/AlO_x/Al Josephson junctions shown in red. (e) The corresponding circuit diagram.

dc-SQUID and the external 50 Ω microwave environment. The dc-SQUID is central to amplification, as it provides the nonlinearity and flux tunability that enable the JPA frequency to be tuned using an external magnetic field. This tunability allows for dynamic control over the frequency of the JPA. Our device features a hybrid design that incorporates coplanar Nb structures, an Nb ground plane, and the dc-SQUID composed of two angle-evaporated, *in-situ* Al/AlO_x/Al Josephson junctions. These junctions are galvanically connected to the ground using the Al bandaging method.

¹We acknowledge support by the German Research Foundation via Germany's Excellence Strategy (EXC-2111-390814868), the German Federal Ministry of Education and Research via the project QUARATE (Grant No. 13N15380). This research is part of the Munich Quantum Valley, which is supported by the Bavarian state government with funds from the Hightech Agenda Bayern Plus.

The gain and bandwidth of a conventional JPA are typically constrained by the finite gain-bandwidth product, meaning that high gain results in narrow bandwidth, which is limited by an external coupling rate. An alternative, dimer JPA design employs two coupled resonators with different characteristic impedances to achieve a broadband amplification response [1]. A corresponding design is shown in Fig. 1. Here, we integrate $\lambda/2$ and $\lambda/4$ resonators in a coplanar waveguide (CPW) geometry, a flux-tunable direct current superconducting quantum interferometer (dc-SQUID), and fish-bone capacitors. The resonators possess different impedances due to different gap-to-width ratios. This allows the input $\lambda/4$ resonator to act as an impedance matching circuit between the $\lambda/2$ cavity, coupled to the capacitively shunted

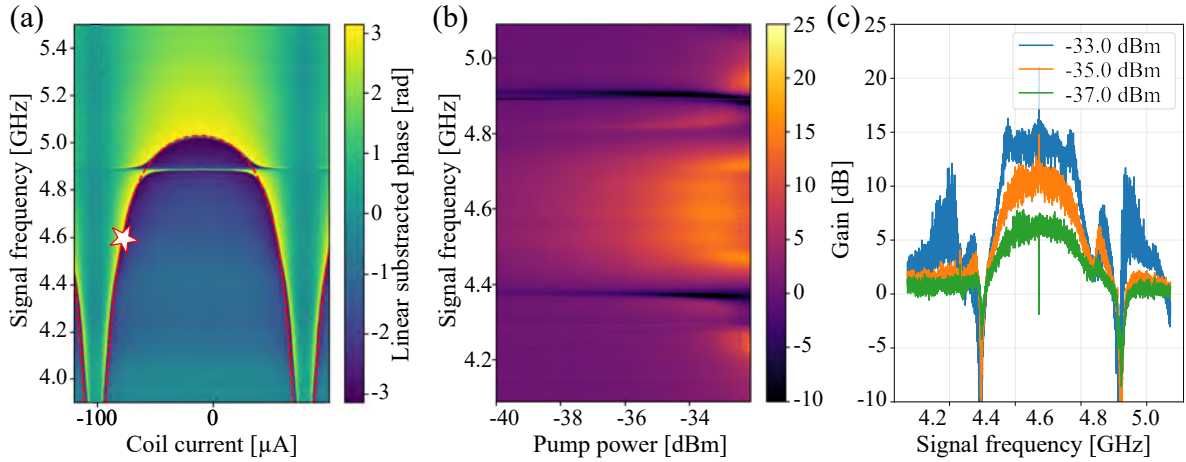

Figure 2: Experimental characterization of the broadband JPA. (a) Flux tuning curve of the broadband JPA. The star symbol indicates the chosen flux working point used in (b). (b) Amplification gain as a function of the pump power and signal frequency, with the pump frequency of 9.18 GHz. Here, the pump powers are referred to the sample pump port. (c) Selected cross-sections of the gain profile.

We characterize the broadband JPA performance at millikelvin temperatures in a dilution cryostat using a vector network analyzer for two-tone spectroscopy measurements. Fig. 2 presents corresponding results. Here, Fig. 2(a) demonstrates the JPA flux-tunable behavior, highlighting a working point used for the gain measurement. This working frequency of 4.59 GHz corresponds to the flux bias of $\Phi_{dc} = 0.39 \Phi_0$ and the pump frequency of 9.18 GHz. We perform gain measurements for a broad range of the pump powers by sweeping the signal frequency over ~ 1 GHz range to illustrate the broadband amplification of our device, as shown in Fig. 2(b). Finally, Fig. 2(c) illustrates gain cross-sections for selected pump powers. At the pump power around -33 dBm, we observe gain around 14 dB over the span of more than 200 MHz. These characteristics greatly, by 2-3 orders of magnitudes, exceed the gain-bandwidth limitations of conventional JPAs. The tunable nature of the dc-SQUID provides additional flexibility, enabling adjustments of the amplifier spectral band.

In conclusion, our broadband JPA design effectively employs the dimer approach based on two coupled cavities. We have experimentally demonstrated the broadband amplification response of this device. Moreover, extra gain measurements as a function of signal power (not shown here) indicate the 1-dB compression power around -117 dBm, referred to the sample input port, which also exceeds conventional JPA characteristics by 2 orders of magnitude. The entirely planar design of our broadband device does not require any additional dielectric layers, which often result in extra losses and increase the amplification noise. We expect the demonstrated devices to become useful for the generation of strongly squeezed microwave signals and for fast, single-shot, readout of multiple superconducting qubits.

References

- [1] T. Roy, S. Kundu, M. Chand, A. M. Vadiraj, A. Ranadive, N. Nehra, M. P. Patankar, J. Aumentado, A. A. Clerk, and R. Vijay, *Applied Physics Letters* **107**, 262601 (2015).

Protected Fluxonium Control with Sub-harmonic Parametric Driving

J. Schirk, F. Wallner, L. Huang, I. Tsitsilin, N. Bruckmoser, L. Koch, K. Liegener, C. M. F. Schneider, S. Filipp¹

Protecting qubits from environmental noise while maintaining strong coupling for fast high-fidelity control is a central challenge for quantum information processing. Here, we investigate a novel approach to controlling superconducting qubits, where we protect the qubit from external noise by impedance engineering its control lines and retain single qubit control using multi-photon processes [1]. We utilize a fluxonium circuit as shown in Fig. 1 (a). Its properties are described by the fluxonium Hamiltonian

$$\hat{H} = 4E_C \hat{n}^2 - E_J \cos \hat{\phi} + \frac{E_L}{2} [\hat{\phi} - \phi(t)]^2, \quad (1)$$

where E_C , E_J and E_L are the capacitive energy, Josephson energy and inductive energy, respectively. The qubit's external flux is controlled by an on-chip flux line, enabling both microwave control and DC biasing in a single line. To investigate the protection of the qubit mode against noise in the flux line, we measure its coherence properties for two different line configurations, where the line either contains no filter or a low-pass filter [see Fig. 1(a)] below the qubit transition frequency ω_q . Incorporating the filter decreases the noise spectral density of the line seen by the qubit, suppressing both free decay and stimulated emission into the line. In turn, the filter increases the relaxation time T_1 and the coherence times T_2^* and T_2^e of the qubit by a factor of 5 to 10, as shown in Fig. 1(b), effectively decoupling the qubit from the noise environment of the flux line. However, in this configuration the qubit can no longer be controlled by applying microwave pulses at ω_q to the qubit. We circumvent this limitation by exploiting the non-linear nature of the fluxonium circuit. By applying a strong microwave signal to the external flux $\phi(t)$ of the qubit at frequencies close to integer fractions $1/n$ of ω_q , the qubit can be driven by absorption and stimulated emission of n photons. Because the frequencies used are much lower than the cut-off frequency of the low-pass filter, the qubit can be controlled while being shielded

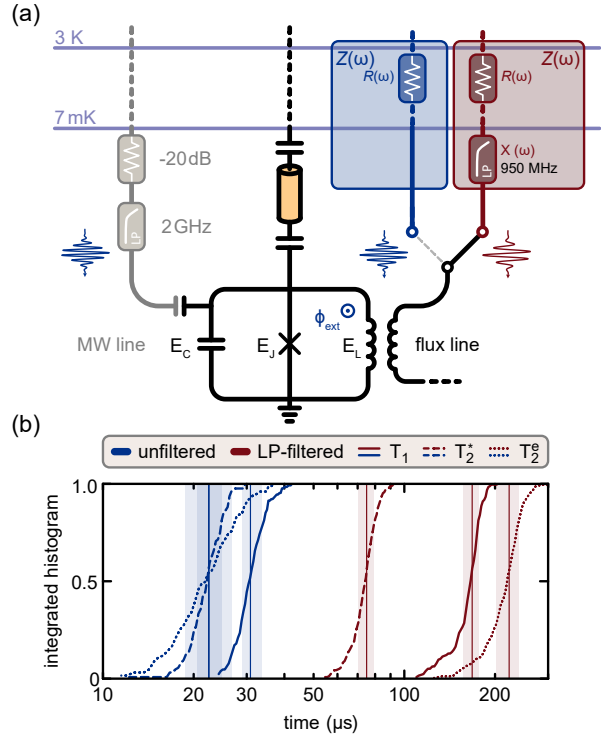

Figure 1: Setup and relaxation times. (a) Setup at the low temperature stages of the cryostat, including readout resonator and two switchable flux line configurations (unfiltered and low-pass (LP) filtered). An additional microwave (MW) line is added for comparison and benchmarking. (b) Integrated histograms for T_1 (solid), T_2^* (dashed), and T_2^e (dotted) for unfiltered (blue) and filtered (red) flux line configuration. Vertical lines with shaded areas illustrate the median and standard deviation.

¹We acknowledge financial support from the German Federal Ministry of Education and Research via the funding program quantum technologies - from basic research to the market under contract number 13N15680 "GeQCoS" and under contract number 13N16188 "MUNIQC-SC" as well as by the Deutsche Forschungsgemeinschaft (DFG, German Research Foundation) via project number FI2549/1-1 and the Germany's Excellence Strategy EXC-2111-390814868 'MCQST', as well as the Horizon Europe programme HORIZON-CL4-2022-QUANTUM-01-SGA via the project 101113946 (OpenSuperQPlus100). The research is part of the Munich Quantum Valley, which is supported by the Bavarian state government with funds from the Hightech Agenda Bayern Plus.

from the noise of the flux line. We investigate this drive scheme for different photon numbers n , starting from a 3-photon sub-harmonic drive up to a 11-photon drive. For the photon numbers 3, 5, 7 and 11, we measure the Rabi frequency Ω as a function of drive amplitude Φ [see Fig. 2 (a)] and compare it to numerical simulations and an analytic model (for the 3- and 5-photon drive). All transitions follow an approximate power-law dependence, which is in excellent agreement with theoretical predictions. Moreover, the observed higher-order power scaling implies additional beneficial properties of this driving method with respect to crosstalk suppression.

Additionally, we demonstrate the equivalence of a 3-photon sub-harmonic drive to an on-resonance drive via randomized benchmarking. We compare three single-qubit gate implementations: a resonant single-qubit gate without a low-pass filter, a resonant single-qubit gate through an auxiliary microwave line with a flux-line low-pass filter, and a 3-photon sub-harmonic gate. All gates have a duration of 64 ns to facilitate a quantitative comparison. The 3-photon sub-harmonic gate achieves fidelities similar to the resonant gate with filtering, with fidelities of 99.941(4)% and 99.969(2)%, respectively (see Fig. 2(b)). We are confident that the remaining difference in fidelity can be improved using optimal-control techniques. In contrast, the unfiltered configuration shows significantly lower fidelity, with an average of 99.878(5)%, highlighting the effectiveness of our noise-protection strategy.

Our findings demonstrate a method to mitigate dissipation in fluxonium qubits through their control environment, while maintaining rapid, high-fidelity single-qubit control. This approach offers a promising pathway toward scalable quantum processors based on fluxonium qubits.

References

- [1] J. Schirk, F. Wallner, L. Huang, I. Tsitsilin, N. Bruckmoser, L. Koch, D. Bunch, N. J. Glaser, G. B. P. Huber, M. Knudsen, G. Krylov, A. Marx, F. Pfeiffer, L. Richard, F. A. Roy, J. H. Romeiro, M. Singh, L. Södergren, E. Dionis, D. Sugny, M. Werninghaus, K. Liegener, C. M. F. Schneider, and S. Filipp. Protected Fluxonium Control with Sub-harmonic Parametric Driving. [arXiv:2410.00495](https://arxiv.org/abs/2410.00495) (2024).

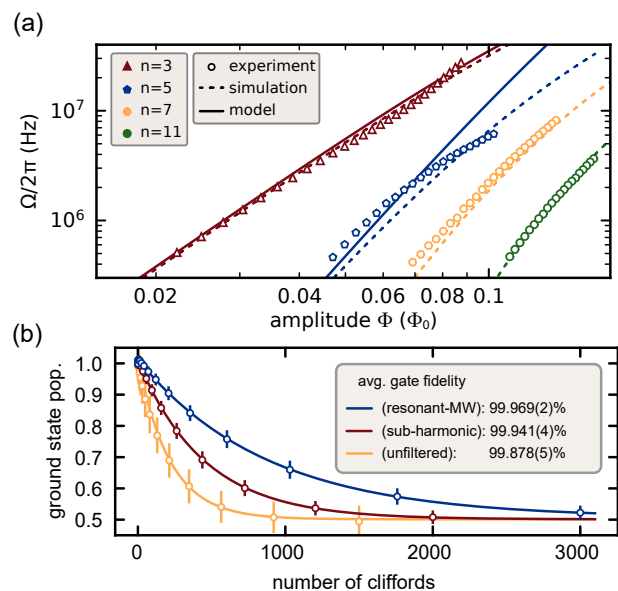

Figure 2: Rabi frequencies for n -photon sub-harmonic drives. (a) Rabi frequencies Ω_n as a function of pulse amplitude Φ for different sub-harmonic drives, compared to numerical simulation and an analytic model. (b) Randomized benchmarking for different single-qubit gate implementations. The fidelity is determined from the ground state population as a function of number of random Clifford gates averaged over 24 hours.

Theory of Sub-harmonic Driving via Multi-Photon Processes in Superconducting Qubits

*J. Luneau, L. Huang, S. Filipp, P. Rabl, K. Liegener*¹

The conventional method for driving a quantum system involves depositing energy, e.g., via photons, exactly at the frequency of a specific transition within the system. Off-resonant frequencies typically yield significantly suppressed contributions, allowing for precise targeting of resonant transfer rates. This resonant driving results in qubit gates with remarkable fidelities, particularly demonstrated in superconducting qubits at institutions like WMI. Recently, the concept of sub-harmonic driving has gained attention. This approach drives the system at a natural fraction of the transition frequency. While these processes can be difficult to control in most systems, developing a general theory of sub-harmonic drives and explaining why fluxonium qubits are particularly well-suited for this technique is possible.

Perturbative treatment of multi-photon processes

The quantum computing and quantum theory teams at WMI have created a scheme that clarifies the weak driving of quantum systems away from their resonance frequency, which is generally described by a Hamiltonian of the form

$$\hat{H}(t) = \hat{H}_0 + e^{-i\omega_d t} \hat{V} + e^{i\omega_d t} \hat{V}^\dagger, \quad (1)$$

where \hat{V} is the drive operator whose frequency is a sub-harmonic of a transition frequency, $\omega_d \simeq \omega_q/n$. A perturbative treatment of the driving terms enables us to derive an effective Hamiltonian for the system, which describes its long-term behavior. This Hamiltonian couples the states $|0\rangle$ and $|1\rangle$, which are separated by approximately an integer multiple of the driving frequency.

$$H_{\text{eff}} = \begin{pmatrix} \delta_0 & \Omega_R \\ \Omega_R^* & \delta_1 \end{pmatrix}, \quad (2)$$

where Ω_R is the Rabi rate, and $\delta_{0/1}$ are the Stark shifts of the energy levels. When assuming a periodic drive, Floquet theory can be utilized [1], leading to the creation of virtual states that facilitate the transfer of population between isolated states (see Fig. 1). Conceptually, the drive can deposit a photon whose energy raises the system to the nearest virtual Floquet state. Hence, multiple photons are required until the system can perform the full transfer to the next physical state. Noteworthy, such a process is suppressed by the energy separation of the Floquet states. On the technical level, the sub-harmonic resonant condition translates into a degeneracy lifted by the drive in the Floquet Hamiltonian. Degenerate perturbation theory predicts the effective Hamiltonian in a systematic power series of the drive amplitude, whose contributions can be expressed diagrammatically in terms of virtual processes, as shown in Fig. 1. The general treatment computed at WMI allows the estimation of this multi-photon process for any number of drive frequencies (sub-harmonic or not) as long as the perturbative treatment remains valid.

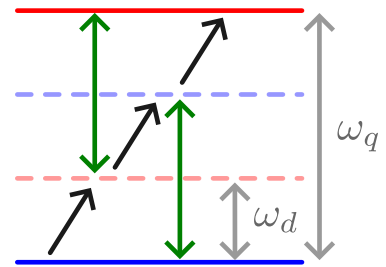

Figure 1: Subharmonic Rabi model. Diagrammatic representation of the lowest order Rabi rate for a three-photon process. The blue and red solid lines represent the initial and final states. The black arrows represent energy increase after the photon absorption and transition to a virtual Floquet state (dashed lines). The green arrows indicate the weight by which each step in the process is suppressed.

¹This project is part of the Munich Quantum Valley, which is supported by the Bavarian state government with funds from the Hightech Agenda Bayern Plus and has received support by the Munich Quantum Valley Quantum Computer Demonstrators - Superconducting Qubits (MUNIQC-SC; project number: 13N16188).

Sub-harmonically driven fluxonium qubits

A fluxonium qubit is a type of superconducting circuit that consists of capacitance, inductance, and a Josephson junction arranged in parallel [2]. This configuration is sensitive to magnetic flux and enables positioning at what is known as the *sweet spot*, where the potential energy of the fluxonium takes on a double-well shape. In this situation, the two lowest-energy eigenstates exhibit a small transition frequency, denoted as ω_q , which is contrasted with a significantly larger anharmonicity, represented as $\alpha > \omega_q$. This characteristic provides natural protection, thereby enhancing the qubit's lifetime.

For instance, when the qubit is driven at approximately one-third of its frequency ($\omega_d \approx \omega_q/3$), the leading order of the Rabi rate can be described by

$$\Omega_{3,\text{Rabi}} = -\frac{V_{01}^3}{4\omega_d^2} + \frac{V_{01}V_{12}^2}{2\omega_d(2\omega_q + \alpha - 2\omega_d)}. \quad (3)$$

The Rabi rate interestingly decomposes into a sum of two processes that interfere destructively. The first process corresponds to virtual transitions between the two lowest energy levels (see Fig. 1), while the second process is related to transitions to the state $|2\rangle$ and is suppressed by a large anharmonicity α . As a result, the significant anharmonicity of the fluxonium circuit enhances the Rabi rate compared to circuits with lower anharmonicity, such as transmons. This makes fluxonium a preferred system for sub-harmonic driving. Higher-order corrections can also be computed, which become relevant when driving the qubit at large amplitudes to perform fast gates. This has been validated through numerical simulations, as shown in Fig. 2 (b). However, larger amplitudes also lead to a stronger Stark shift, which, at the lowest order, follows a specific relation:

$$\Delta = \frac{3|V_{01}|^2}{2\omega_d} + \frac{2(3\omega_d - 2\omega_q - \alpha)|V_{12}|^2}{(4\omega_d - 2\omega_q - \alpha)(2\omega_d - 2\omega_q - \alpha)}. \quad (4)$$

The Stark shifts, predicted in Fig. 2 (a), are used for resonant frequency of sub-harmonic driving. Additionally, when considering higher-photon processes, we can predict the power law associated with Stark shifts and the Rabi rate. From an experimental perspective, driving qubits at their resonant frequency allows for lifetime protection when a low-pass filter is incorporated at the qubit frequency in the drive lines. This phenomenon has also been observed this year in fluxonium experiments at WMI [3] (see the corresponding article on page 75).

References

- [1] J. H. Shirley, *Phys. Rev.* **138**, B979 (1965).
- [2] V. E. Manucharyan, J. Koch, L. I. Glazman, and M. H. Devoret, *Science* **326**, 113 (2009).
- [3] J. Schirk, F. Wallner, and et al. Protected Fluxonium Control with Sub-harmonic Parametric Driving. [arXiv:2410.00495](https://arxiv.org/abs/2410.00495) (2024).

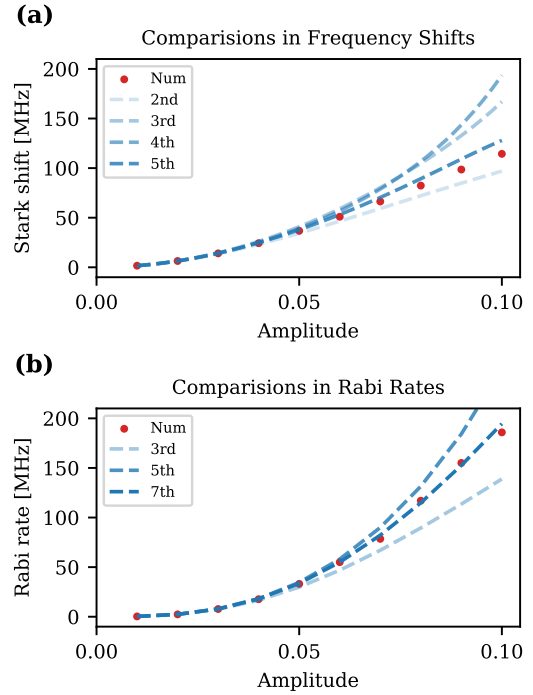

Figure 2: Stark shift (a) and Rabi rate (b) computed at different orders in perturbation theory (dashed lines) compared to the numerical simulation of the dynamics (red dots).

Towards Storage of Squeezed States in Spin Ensembles

*F. Fesquet, P. Oehrl, K. E. Honasoge, M. Handschuh, A. Marx, R. Gross, H. Huebl, K. G. Fedorov*¹

Superconducting quantum circuits operating at microwave frequencies represent one of the leading platforms for quantum information processing. In order to unlock its full potential, the superconducting quantum systems must advance from singular chips to distributed quantum networks, where quantum communication and quantum memories operating at microwave frequencies represent critical building blocks. While fundamental quantum communication protocols have been demonstrated to work with squeezed microwave states [1, 2], implementation of quantum memories with long relaxation times remains a significant experimental challenge. Here, solid-state spin ensembles represent a promising platform for long-lived microwave quantum memories, as they possess resonant GHz transitions tunable via the Zeeman interaction with an external magnetic field, B . Phosphorus donor atoms embedded in isotopically purified silicon crystals have been extensively studied in the past and possess extremely long relaxation times with reported $T_1 \geq 10$ s at cryogenic temperatures [3]. In this context, we experimentally investigate the coupling of microwave squeezed states to a phosphorus-doped silicon spin ensemble.

In our experiment, we generate microwave squeezed states using a Josephson parametric amplifier (JPA), which consists of a $\lambda/4$ coplanar waveguide resonator shorted to ground via a direct-current superconducting quantum interference device (dc-SQUID). The dc-SQUID provides a nonlinear inductance that allows for the flux-tunability of the JPA. Driving the JPA with a strong coherent tone at twice its resonance frequency enables a degenerate parametric amplification process which leads to squeezing of JPA input signals. These states are guided to a superconducting resonator coupled to a spin ensemble, as shown in Fig. 1. The latter consists of a silicon host crystal doped with phosphorus atoms at a doping concentration of $[P] = 10^{17} \text{cm}^{-3}$. When in resonance with the spin ensemble transition frequencies, the resonator modes couple to spins resulting in a hybrid resonator-spin system. The Hamiltonian of this system is described based on the Tavis-Cummings Hamiltonian [4]

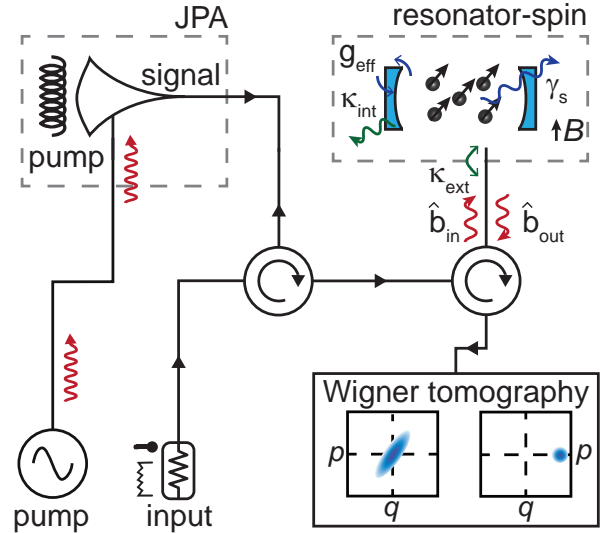

Figure 1: Scheme of the experimental setup. System parameters are from the Hamiltonian in Eq. 1 which provides a detailed model for interactions between the external microwave signals and the resonator-spin system. For each output signal, we perform a Wigner tomography using a Planck spectroscopy which is experimentally realized with an input heatable attenuator. Color plots depict exemplary Wigner functions.

$$\frac{\hat{H}}{\hbar} = \sum_j^N \left[g_j (\hat{\sigma}_-^j \hat{a}^\dagger + \hat{\sigma}_+^j \hat{a}) + \frac{\Delta_j}{2} \hat{\sigma}_z^j + \sqrt{2\gamma_s} (\hat{\sigma}_-^j \hat{f}_j^\dagger + \hat{\sigma}_+^j \hat{f}_j) \right] + \left[(\sqrt{\kappa_{\text{int}}} \hat{b}_l + \sqrt{\kappa_{\text{ext}}} \hat{b}_{\text{in}}) \hat{a}^\dagger + H.c. \right], \quad (1)$$

¹We acknowledge support by the German Research Foundation via Germany's Excellence Strategy (EXC-2111-390814868), the German Federal Ministry of Education and Research via the project QUARATE (Grant No. 13N15380), and the project QuaMToMe (Grant No. 16KISQ036). This research is part of the Munich Quantum Valley, which is supported by the Bavarian state government with funds from the Hightech Agenda Bayern Plus.

where $g_j = g_{\text{eff}}/\sqrt{N}$ is the coupling of a single spin to a resonator mode \hat{a} , Δ_j is the detuning of the j -th spin for N coupled spins to the resonator frequency and γ_s is a dephasing rate modelling spin decoherence with a noise mode \hat{f}_j associated to the j -th individual spin. Additionally, we account for internal cavity losses with associated mode \hat{b}_l and rate κ_{int} . The resonator-spin system is coupled to input microwave modes, \hat{b}_{in} , via a coupling rate κ_{ext} .

We perform a Wigner tomography of outgoing microwave signals using a heterodyne detection setup from which we compute I/Q moments of measured signals up to the fourth order. These combined moments are used to extract an output variance, $\sigma_{s,\text{out}}^2$, of the states, which we characterize with a squeezing level $S = -10 \log_{10}(\sigma_{s,\text{out}}^2/0.25)$. Using Eq. 1, we can derive that this output variance is related to the variance $\sigma_{s,\text{in}}^2$ at the input of the resonator-spin system as

$$\sigma_{s,\text{out}}^2 = r^2 \sigma_{s,\text{in}}^2 + l^2 \sigma_1^2 + t^2 \sigma_{\text{spin}}^2 \quad (2)$$

where r , s , and t are coefficients dependent on the experimental parameters which fulfil the condition $r^2 + l^2 + t^2 = 1$. Here, the variance σ_1^2 originates from a thermal bath associated with the resonator's internal losses. Similarly, σ_{spin}^2 is associated with a thermal bath formed by the spin ensemble. Both thermal baths are assumed to be at a temperature of $T = 142$ mK, according to characterization measurements. In Fig. 2, we show measured squeezing levels, where positive values, $S > 0$, indicate squeezing below vacuum fluctuations. Here, we perform three different measurements. First, we measure squeezing for the completely detuned case, where both the resonator and spins are detuned from the JPA frequency. In a second step, we tune the resonator into resonance with the JPA at the common frequency of 5.6169 GHz. Finally, the spins are also tuned in resonance at the joint frequency of 5.61724 GHz leading to a significant decrease in the measured squeezing level. We interpret this observation as a successful coupling of the incoming squeezed states to the spin ensemble. Based on our model, we estimate a coupling of $t^2 \simeq 36\%$ to the spin ensemble. We observe a good agreement between the model and the measurements, as illustrated by Fig. 2. We note that for large pump powers above -20 dBm, the model starts to diverge from the measurements. We attribute this deviation to higher-order nonlinearities in the JPA. Further analysis and measurements are ongoing.

In conclusion, our preliminary measurement results have demonstrated that microwave squeezed states can be controllably coupled to spin ensembles, leading to potential applications in quantum communication with quantum memories at microwave frequencies.

References

- [1] A. M. Tyryshkin, S. Tojo, J. J. L. Morton, H. Riemann, N. V. Abrosimov, P. Becker, H.-J. Pohl, T. Schenkel, M. L. W. Thewalt, K. M. Itoh, and S. A. Lyon, *Nat. Mater.* **11**, 143–147 (2012).
- [2] L. Zhong, E. P. Menzel, R. Di Candia, P. Eder, M. Ihmig, A. Baust, M. Haeberlein, E. Hoffmann, K. Inomata, T. Yamamoto, Y. Nakamura, E. Solano, F. Deppe, A. Marx, and R. Gross, *New J. Phys.* **15**, 125013 (2013).
- [3] E. P. Menzel, R. Di Candia, F. Deppe, P. Eder, L. Zhong, M. Ihmig, M. Haeberlein, A. Baust, E. Hoffmann, D. Ballester, K. Inomata, T. Yamamoto, Y. Nakamura, E. Solano, A. Marx, and R. Gross, *Phys. Rev. Lett.* **109**, 250502 (2012).
- [4] A. Bienfait, P. Campagne-Ibarcq, A. H. Küllerich, X. Zhou, S. Probst, J. J. Pla, T. Schenkel, D. Vion, D. Esteve, J. J. L. Morton, K. Moelmer, and P. Bertet, *Phys. Rev. X* **7**, 041011 (2017).

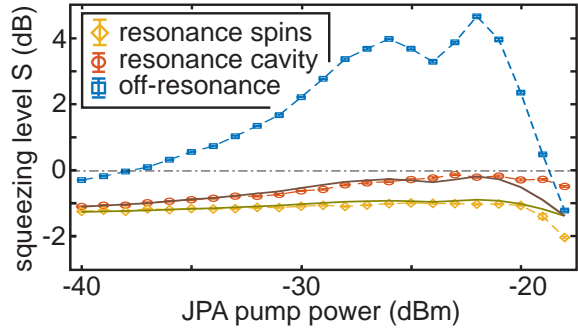

Figure 2: Squeezing level as a function of the JPA pump power for the three different experimental scenarios, as described in the main text. The solid lines represent model predictions based on Eq. 2 using the off-resonance squeezing levels as an input.

Robust Single-Qubit Gates

*E. Wright, N.J. Glaser, M. Werninghaus, F. Roy, J. Enghardt, S. Filipp*¹
*L. van Damme, A. Devra, S.J. Glaser*²

High fidelity gate operations are a key ingredient to achieve error corrected quantum computations. State of the art single qubit gates on transmon qubits achieve fidelities greater than 99.9% [1]; however, parameter drifts necessitate frequent re-calibrations to maintain the fidelities. Such parameter drifts are introduced by instabilities in the qubit and changes in the environment. We investigate the performance of robust gates derived from a Fourier series parametrization and a standard parametrization based on Gaussian pulses with 'Derivative Removal by Adiabatic Gate' (DRAG) corrections [2], implementing a $X_{\pi/2}$ gate.

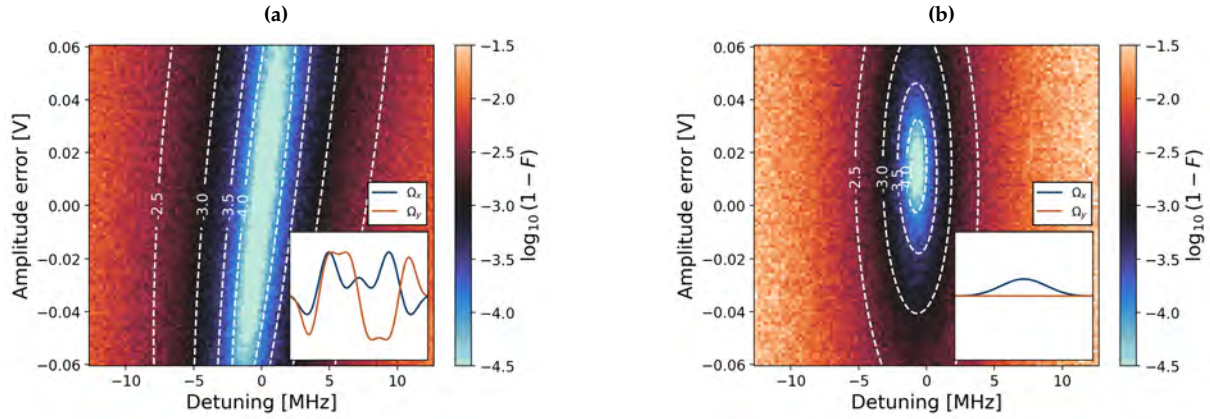

Figure 1: Gate infidelity $1 - F$ (Eq. 3) for (a) robust gates derived from a Fourier series parametrization and (b) Gaussian pulses with DRAG corrections, with various amplitude and detuning errors, simulated using Eq. 1. To highlight the differences, the gate infidelity is shown on a log scale. The contour lines correspond to gate fidelities of 99.99% to 99.68%. Corresponding pulse envelopes for the gates with a length of 100 ns are shown in the insets.

The dynamics of a truncated transmon qubit [3] are modeled by the Hamiltonian

$$H = (1 + \gamma) \begin{pmatrix} 0 & \frac{\Omega_x - i\Omega_y}{2} & 0 \\ \frac{\Omega_x + i\Omega_y}{2} & 0 & \frac{\Omega_x - i\Omega_y}{\sqrt{2}} \\ 0 & \frac{\Omega_x + i\Omega_y}{\sqrt{2}} & 0 \end{pmatrix} + \delta \begin{pmatrix} 0 & 0 & 0 \\ 0 & 1 & 0 \\ 0 & 0 & 2 \end{pmatrix} + \alpha \begin{pmatrix} 0 & 0 & 0 \\ 0 & 0 & 0 \\ 0 & 0 & 1 \end{pmatrix}, \quad (1)$$

where Ω_x, Ω_y are the in-phase and quadrature components of the pulse, α is the qubit anharmonicity, γ is a pulse amplitude error, and δ is a detuning error. The robust pulse takes the form

$$\Omega_x(t) = \sum_{n=1}^5 a_n \sin((2n-1)\pi t) \text{ and } \Omega_y(t) = \sum_{n=1}^5 b_n \sin(2n\pi t), \quad (2)$$

where a_n, b_n represent the Fourier series coefficients and n enumerates the Fourier components. We simulate the gate dynamics according to the Hamiltonian in Eq. 1 for variations in

¹We acknowledge financial support from the German Federal Ministry of Education and Research via the funding program quantum technologies - from basic research to the market under contract number 13N15680 "GeQCoS" and under contract number 13N16188 "MUNIQC-SC" as well as by the Deutsche Forschungsgemeinschaft (DFG, German Research Foundation) via project number FI2549/1-1 and the Germany's Excellence Strategy EXC-2111-390814868 'MCQST', as well as the Horizon Europe programme HORIZON-CL4-2022-QUANTUM-01-SGA via the project 101113946 (OpenSuperQPlus100). The research is part of the Munich Quantum Valley, which is supported by the Bavarian state government with funds from the Hightech Agenda Bayern Plus. Emily Wright further acknowledges the financial support of the International Max Planck Research School for Quantum Science and Technology (IMPRS-QST).

²Technical University of Munich, Munich Center for Quantum Science and Technology

amplitude and detuning. We perform a gradient-based search for a set of $n = 5$ components that minimize both the distance to a target gate and the leakage over all detunings and amplitude errors simultaneously at a gate length of 100 ns. For amplitude errors spanning -0.06 V to 0.06 V and detuning from -15 MHz to 15 MHz, we estimate the gate fidelity

$$F = \left| \text{tr}(U_{\text{Target}}^\dagger U(t_g)) \right|^2 \quad (3)$$

between the unitary gate $U(t_g)$ implemented by a pulse of length $t_g = 100$ ns and the target unitary gate U_{Target} which describes an $X_{\pi/2}$ gate. The resulting cost landscapes are shown in Fig. 1. The robust pulse maintains a gate fidelity of 99.99% across a detuning of 2.80 MHz and 0.10 V in amplitude variation, while the DRAG gate covers only a spread of 1.57 MHz and 0.03 V, as indicated by the contour lines in Fig. 1.

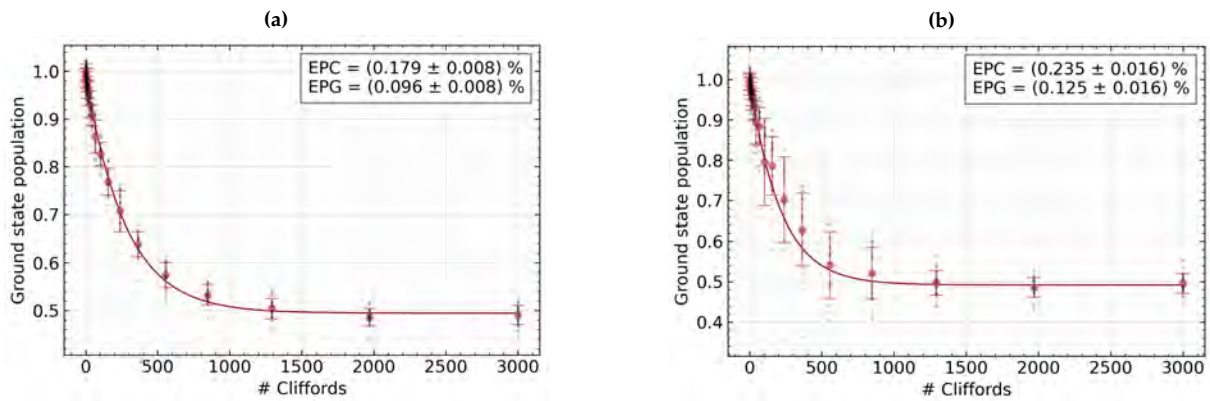

Figure 2: Randomized benchmarking for (a) robust gates derived from a Fourier series parametrization and (b) Gaussian pulses with DRAG corrections. The error per Clifford (EPC) and error per gate (EPG) are estimated by fitting an exponential function to the experimental data.

We implement the Fourier series pulse shape on an experimental system with fixed-frequency transmon-type qubits. We calibrate the robust pulse and the Gaussian DRAG corrected pulse to implement correct rotation angles and resonance conditions. Here, only a Rabi-like amplitude calibration is required for the robust pulse, whereas the Gaussian DRAG pulse requires a more precise calibration via error amplification and the calibration of the DRAG parameter. We obtain a gate fidelity of $99.904 \pm 0.008\%$ for the robust pulse, whereas the fidelity for the Gaussian DRAG pulse is $99.87 \pm 0.02\%$, with the data shown in Fig 2. The reduced unitary error of the gate during the benchmarking is not only observed in the gate fidelity, but also via the reduced spread of the individual sequences [4]. As the full measurement of a randomized benchmarking experiment requires 13 minutes, this hints towards possible robustness to parameter drifts during the measurement. A comprehensive analysis of the gate stability and susceptibility to noise channels in experiment is ongoing.

References

- [1] P. Jurcevic, A. Javadi-Abhari, L. S. Bishop, I. Lauer, D. F. Bogorin, M. Brink, L. Capelluto, O. Günlük, T. Itoko, N. Kanazawa, A. Kandala, G. A. Keefe, K. Krsulich, W. Landers, E. P. Lewandowski, D. T. McClure, G. Nannicini, A. Narasgond, H. M. Nayfeh, E. Pritchett, M. B. Rothwell, S. Srinivasan, N. Sundaresan, C. Wang, K. X. Wei, C. J. Wood, J.-B. Yau, E. J. Zhang, O. E. Dial, J. M. Chow, and J. M. Gambetta, *Quantum Science and Technology* **6**, 025020 (2021).
- [2] F. Motzoi, J. M. Gambetta, P. Rebentrost, and F. K. Wilhelm, *Phys. Rev. Lett.* **103**, 110501 (2009).
- [3] J. Koch, T. M. Yu, J. Gambetta, A. A. Houck, D. I. Schuster, J. Majer, A. Blais, M. H. Devoret, S. M. Girvin, and R. J. Schoelkopf, *Phys. Rev. A* **76**, 042319 (2007).
- [4] H. Ball, T. M. Stace, S. T. Flammia, and M. J. Biercuk, *Phys. Rev. A* **93**, 022303 (2016).

Mitigating Phase Velocity Mismatch in Flux-Pumped Josephson Traveling Wave Parametric Amplifiers

D. E. Bazulin, K. Kiener, L. A. Anhalt, N. Bruckmoser, M. Grammer, M. Althammer, S. Geprägs, S. Filipp and K. G. Fedorov^{1 2}

Simultaneous single-shot readout of multiple qubits is one of the critical challenges in scalable quantum computing with superconducting circuits. Josephson traveling wave parametric amplifiers (JTWPAs) are well-suited to resolve this issue by utilizing wave-mixing processes in extended nonlinear media. These devices can achieve broadband amplification response at microwave frequencies with the noise performance close to the standard quantum limit. The nonlinear medium in JTWPAs is usually based on chains of Josephson junctions or related superconducting nonlinear elements, e.g. SNAILs [1].

One distinctive feature of JTWPAs is an ability to exploit a flux-pumping scheme [2], in which the pump mode propagates via a separate linear transmission line, inductively coupled to the nonlinear medium, consisting of SNAILs, as illustrated in Fig. 1a. Here, parametric amplification is achieved by a time-varying modulation of the Josephson inductance. This approach eliminates restriction on the applied pump power due to absence of Josephson structures with finite critical current and therefore avoids the pump depletion problem. Another advantage of flux-pumping is mitigation of the pump mode up-conversion processes, which represent a significant loss channel for other TWPAs approaches [3].

An experimental challenge towards implementation of the flux-pumped JTWPAs is represented by a phase velocity mismatch between signal and pump tones, as shown in Fig. 1b. A large difference between the corresponding phase velocities eventually leads to a destructive nonlinear interference between the co-propagating signal and pump tones, resulting in a reduced efficiency of the amplification process (see Fig. 1c). This challenge requires modifying the linear pump waveguide to decrease its phase velocity. One possible approach involves changing effective permittivity and permeability of the medium, by using dielectrics with high dielectric constant or high kinetic inductance materials. An

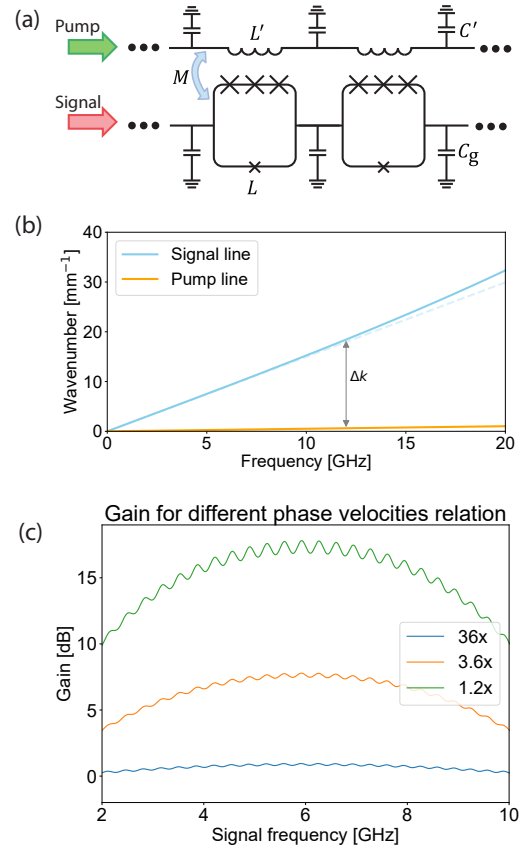

Figure 1: (a) Circuit schematic of a flux-pumped JTWPA based on SNAILs. A linear pump waveguide is inductively coupled to a nonlinear signal medium consisting of SNAILs. (b) Dispersion relation for the signal and the pump lines. (c) Predicted gain of the flux-pumped JTWPA as a function of frequency for varying phase velocity ratios between the pump and signal tones.

¹We acknowledge support by the German Research Foundation via Germany's Excellence Strategy (EXC-2111-390814868), by the German Federal Ministry of Education and Research via the project GeCQoS (FKZ 13N15680), the project QUARATE (Grant No. 13N15380). This research is part of the Munich Quantum Valley, which is supported by the Bavarian state government with funds from the Hightech Agenda Bayern Plus.

²We acknowledge support by Y. Yuan and M. Haider from TUM School of Computation, Information and Technology, Technical University of Munich, Hans-Piloty-Str. 1, 85748 Garching, Germany

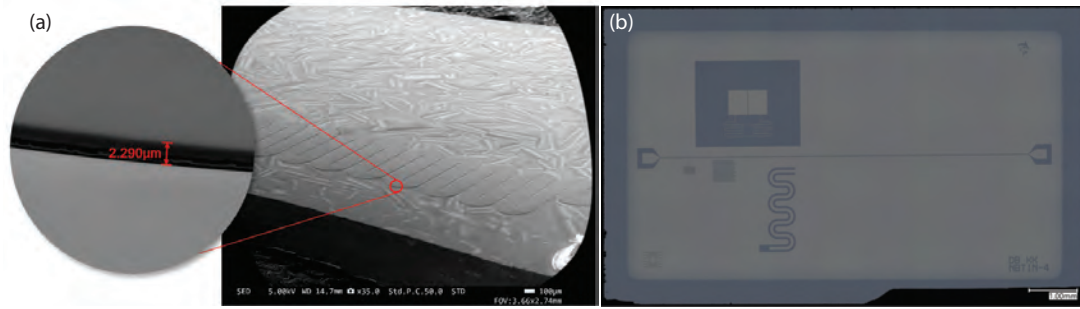

Figure 2: (a) SEM picture of a chip with 2 μm thick layer SrTiO₃ patterned over a superconducting meandered line. (b) Optical photo of a chip with 15 nm thin film of NbTiN with patterned test resonators.

alternative solution is to engineer the pump dispersion relation by adding a series of linear resonators in the corresponding line.

In this context, promising dielectric materials are titanium dioxide (TiO₂), with a dielectric constant ranging from 13 to 250, depending on temperature and crystallinity [4] and strontium titanate (SrTiO₃), with a dielectric constant up to $\sim 10^4$ at millikelvin temperatures, strongly influenced by its crystallinity as well [5]. These properties make strontium titanate the most promising candidate for this purpose. Figure 2a illustrates a test chip fabricated to characterize dielectric properties of a SrTiO₃ layer deposited at WMI facilities.

The alternative approach to reduce the phase velocity mismatch is based on using high kinetic inductance materials, such as NbTiN. Depending on a corresponding film thickness, its inductance can reach values up to hundreds of pH/square [6]. Unfortunately, thin NbTiN films may introduce a significant nonlinearity into the pump line, enabling undesired processes there, such as up-conversion and self-phase modulation. However, a relatively short length of the pump line in our designs should limit the detrimental effect of these processes.

This work is in progress and currently focuses on optimization of deposition processes and careful extraction of relevant parameters, such as dielectric constants or microwave phase velocities, at millikelvins. Currently, we are characterizing 15 nm thick NbTiN films (Fig 2b), and superconducting resonators coated with titanium oxide and strontium titanate of different thicknesses to investigate their actual properties in application to our standard JTWPA designs.

References

- [1] N. E. Frattini, U. Vool, S. Shankar, A. Narla, K. M. Sliwa, and M. H. Devoret, *Applied Physics Letters* **110** (2017).
- [2] A. Zorin, *Physical Review Applied* **12**, 044051 (2019).
- [3] M. Haider, *IEEE Transactions on Microwave Theory and Techniques* **72**, 2143–2157 (2024).
- [4] V. Dang, H. Parala, J. H. Kim, K. Xu, N. B. Srinivasan, E. Edengeiser, M. Havenith, A. D. Wieck, T. de los Arcos, R. A. Fischer, and A. Devi, *physica status solidi (a)* **211**, 416–424 (2013).
- [5] B. A. Baumert, L.-H. Chang, A. T. Matsuda, T.-L. Tsai, C. J. Tracy, R. B. Gregory, P. L. Fejes, N. G. Cave, W. Chen, D. J. Taylor, T. Otsuki, E. Fujii, S. Hayashi, and K. Suu, *Journal of Applied Physics* **82**, 2558–2566 (1997).
- [6] T. M. Bretz-Sullivan, R. M. Lewis, A. L. Lima-Sharma, D. Lidsky, C. M. Smyth, C. T. Harris, M. Venuti, S. Eley, and T.-M. Lu, *Applied Physics Letters* **121** (2022).

Materials, Thin Film and Nanotechnology, Experimental Techniques

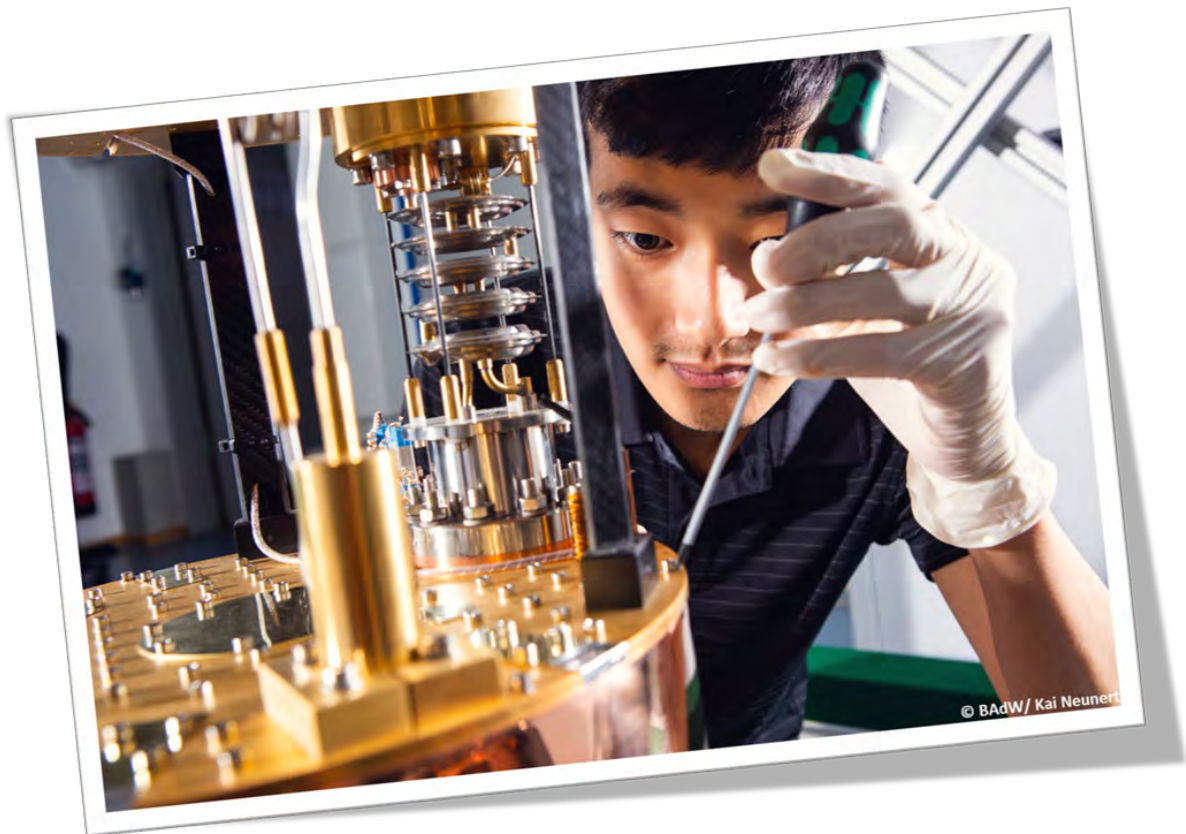

Progress in High Coherence Qubit Fabrication

*L. Koch, N. Bruckmoser, D. Bunch, L. Richard, J. Feigl, K. Honasoge, M. Handschuh, T. Luschmann, C. Gnandt, A. Skoczylas, A. Scoles, V. Bader, L. Södergren, S. Filipp*¹

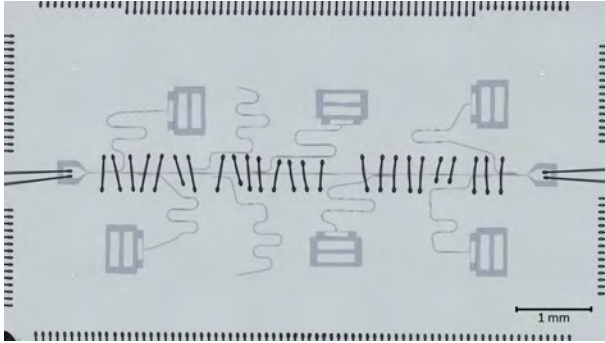

Figure 1: Micrograph of a test chip with six qubits coupled to a common transmission line via CPW resonators. Two additional CPW resonators are available to disentangle losses from the groundplane and the Josephson junctions.

qubit coherence and overall system reliability. In order to minimize TLSs, special attention during fabrication is given to the interfaces between metal, air, and substrate, as they host a high density of TLSs, embedded in surface oxides [2].

Over the past year, we have further reduced TLS density at interfaces by optimizing cleaning procedures. Building on our experience with coplanar waveguide resonators, we introduced a buffered oxide etch (BOE) cleaning process into the qubit fabrication workflow. This process uses a hydrofluoric acid solution to remove lossy oxides from the silicon substrate and niobium ground plane surfaces. By applying a BOE treatment at critical stages during fabrication, we gain improved control over key interfaces within our qubit chips. An exemplary packaged chip containing six qubits is shown in Fig. 1. Additionally we optimized our reactive ion etching parameters, the liftoff process for Josephson junctions and developed new processes to be able to fabricate Josephson junction arrays based on a Dolan bridge approach. The work in the last project year has led to improvements in transmon qubit lifetimes, which now exhibit record high average lifetimes of 420 μs as shown in Fig. 2. The capability to fabricate junction arrays has further expanded our ability to produce various qubit types, such as fluxonium qubits.

Ongoing efforts will focus on enhancing fabrication yield and reproducibility, as well as

Achieving error correction on a superconducting quantum computer requires high-fidelity gate operations, which in turn depend on long coherence times of the physical qubits. In state-of-the-art systems, the qubit coherence is typically constrained by material losses. Extending these coherence times, therefore, demands advanced fabrication techniques to minimize these losses.

In superconducting circuits, the predominant source of such losses is two-level systems (TLS) within materials. These TLS defects interact with qubits via their dipole moments, introducing noise leading to decay and decoherence [1]. Reducing TLS-related losses has thus become a focus in improving

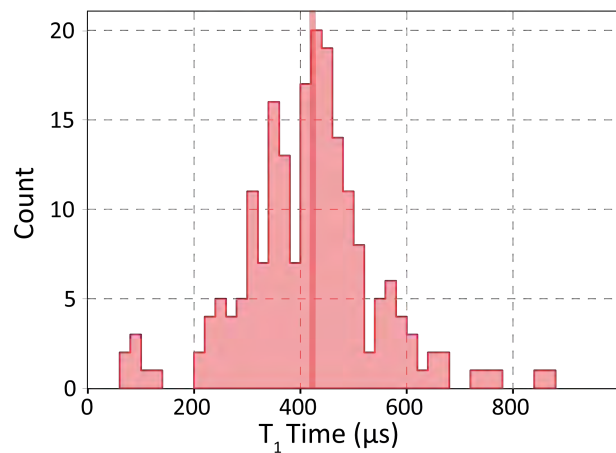

Figure 2: Distribution of transmon qubit T_1 times monitored over 12 hours.

¹This project has received support by the BMBF (GeCQoS; project No. 13N15680), the Munich Quantum Valley - Superconducting Qubits (MUNIQC-SC; project No. 13N16188), and the Munich Quantum Valley, which is supported by the Bavarian state government with funds from the Hightech Agenda Bayern Plus

advancing 3D integration techniques to support scalable quantum processor development at the WMI.

References

- [1] M. V. P. Altoé, A. Banerjee, C. Berk, A. Hajr, A. Schwartzberg, C. Song, M. Alghadeer, S. Aloni, M. J. Elowson, J. M. Kreikebaum, E. K. Wong, S. M. Griffin, S. Rao, A. Weber-Bargioni, A. M. Minor, D. I. Santiago, S. Cabrini, I. Siddiqi, and D. F. Ogletree, [PRX Quantum](#) **3**, 020312 (2022).
- [2] C. R. H. McRae, H. Wang, J. Gao, M. R. Vissers, T. Brecht, A. Dunsworth, D. P. Pappas, and J. Mutus, [Review of Scientific Instruments](#) **91**, 091101 (2020).

3D Integration of Superconducting Resonators

L. Richard, A. Skoczylas, N. Bruckmoser, L. Koch, D. Bunch, J. Feigl, V. Bader, L. Södergen, S. Filipp

As the number of qubits in superconducting quantum processors grows, so does the complexity of the interconnects, leading to challenges such as difficult routing and crosstalk. 3D integration technologies, like flip-chip bonding, present a promising solution by vertically assembling and connecting separate chips and components, which reduces the system's footprint and minimizes line density. This approach reduces crosstalk and facilitates more scalable and reliable quantum computing systems.

This year, the focus has been placed on developing indium bump-based flip-chip bonding for superconducting quantum hardware, with particular attention to ensuring compatibility with high-coherence quantum circuits [1]. Significant progress has been made in the fabrication of high-quality indium bumps for flip-chip bonding. Using thermal evaporation, indium bumps with a thickness of 10 μm and a width of 20 μm were successfully developed, exhibiting a critical temperature of approximately 3.4 K, consistent with the properties of bulk indium. Figure 2 presents the measured resistance of niobium-based coplanar waveguides electrically connected through indium interconnects, as a function of temperature. Two critical transitions are observed, corresponding to niobium and indium, respectively, confirming the superconducting character of the bonds. Additionally, we have established the capability to fabricate 20 μm thick indium bumps, which will be explored in future work with the aim to create more robust and scalable interconnects.

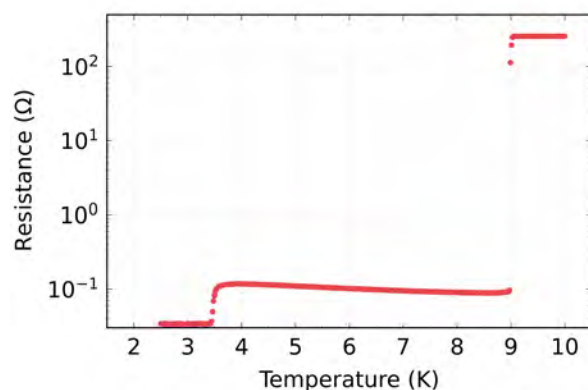

Figure 2: Resistance of a daisy-chains with 18 indium interconnects as a function of temperature.

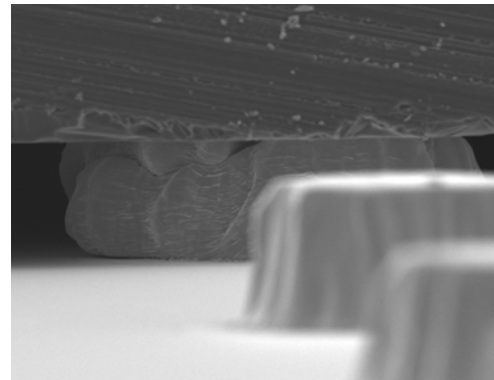

Figure 1: SEM picture of an indium-based interconnect, consisting of two separate indium bumps that were thermally compressed.

To ensure reliable electrical and mechanical connections between the two bonded chips, the indium interconnects are joined using a thermo-compression process with a state-of-the-art flip-chip bonder. A typical bond resulting from the compression of two indium bumps is represented in Figure 1. Parameters such as coupling strength are strongly dependent on the distance separating the two chips after bonding; thus efforts have been made to achieve precise control of the gap while also minimizing shifts and tilt using so called spacers [2].

In parallel, superconducting resonators integrated through flip chip process have achieved quality factors, averaging above 1 million at the single photon limit. This is comparable to resonators fabricated with our typical 2D process. Figure 3 shows a the quality factors of 10 resonators as a function of power, highlighting an average of around 1.25 million for the internal quality factor at very low photon numbers. Such quality factors are critical for maintaining the coherence of superconducting circuits, and these results suggest that the fabrication and integration processes do not introduce signifi-

cant loss mechanisms. This outcome highlights the suitability of the approach for applications where circuit coherence is essential.

In summary, this year’s work has demonstrated that indium bump-based flip-chip bonding is a viable method for 3D integration of superconducting quantum systems. The processes developed support high-coherence quantum circuits and show great promise for scaling, contributing to the ongoing efforts to advance quantum computing technologies. Future efforts will focus on integrating the flip chip process to high coherence qubit fabrication, as well as demonstrating reliable and reproducible parameter targeting for 3D integrated systems.

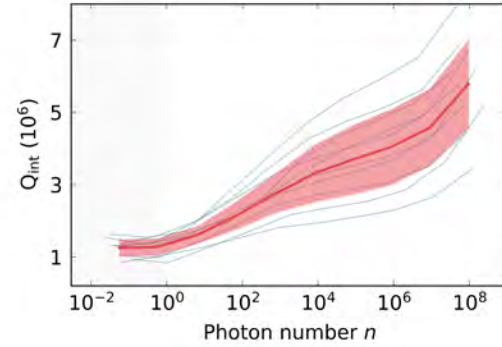

Figure 3: Internal quality factor of 3D integrated resonator as a function of the photon number.

References

- [1] S. Kosen, H.-X. Li, M. Rommel, R. Rehammar, M. Caputo, L. Grönberg, J. Fernández-Pendás, A. F. Kockum, J. Biznárová, L. Chen, C. Križan, A. Nylander, A. Osman, A. F. Roudsari, D. Shiri, G. Tancredi, J. Govenius, and J. Bylander, *PRX Quantum* **5**, 030350 (2024).
- [2] G. J. Norris, L. Michaud, D. Pahl, M. Kerschbaum, C. Eichler, J.-C. Besse, and A. Wallraff, *EPJ Quantum Technology* **11** (2024).

Josephson Junction Annealing for Improved Frequency Targeting

*J. Feigl, L. Koch, F. Wallner, N. Bruckmoser, D. Bunch, M. Handschuh, L. Richard, V. Bader, L. Södergren, S. Filipp*¹

Scaling superconducting quantum processors beyond a small number of qubits necessitates precise frequency targeting. Without this, frequency collisions can result in crosstalk and reduced gate fidelities, significantly impacting processor performance [1]. Thus, improving frequency targeting after fabrication is a critical step in developing large-scale quantum processors based on superconducting qubits.

The fundamental building block of a superconducting qubit is the Josephson junction, which plays an important role in determining the qubit frequency [2]. However, achieving precise parameter targeting during fabrication remains a significant challenge due to the small size of Josephson junctions and variations in the oxide barrier thickness [3, 4]. To address this, we investigate laser annealing of Al/AlO_x/Al Josephson junctions as a post-fabrication method to enhance frequency targeting. Laser annealing locally increases the resistance of individual Josephson junctions through heating with a focused laser beam, providing a promising approach for fine-tuning qubit frequencies [5]. Prior studies have demonstrated the potential of laser annealing to significantly improve frequency targeting [5–7].

The relationship between qubit frequency and room-temperature resistance is described by the Ambegaokar-Baratoff relation, which allows predictions of cryogenic qubit frequency changes from resistance measurements at room temperature [2]. This predictive capability facilitates a stepwise annealing approach, where laser pulses are applied iteratively, with each step informed by the deviation from the target resistance.

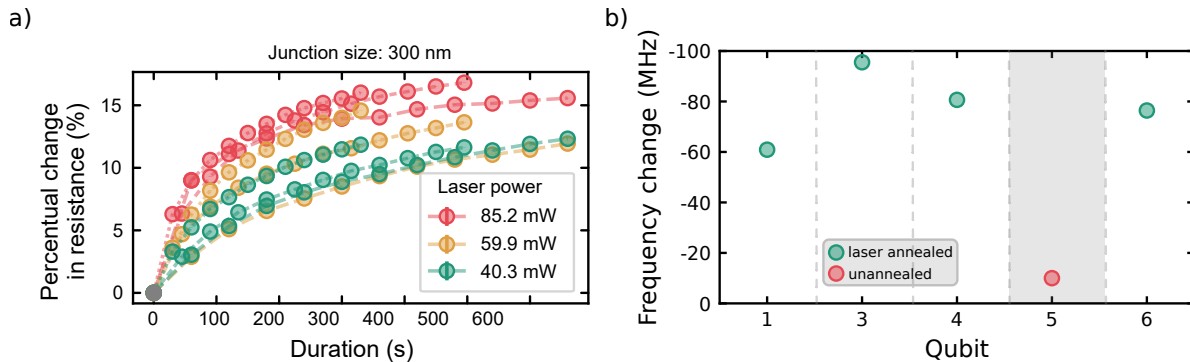

Figure 1: Josephson junction annealing: a) Percentual resistance change over total annealing duration for annealing individual Josephson junctions with 85.2 mW (red), 59.9 mW (yellow), and 85.2 mW (green). Individual annealing steps lasted 30 s, 45 s, or 60 s. b) Cryogenic frequency change of fixed-frequency transmon qubits after laser annealing (green) and without annealing between the two cooldowns (red).

To investigate the influence of laser annealing parameters on Josephson junction resistance, experiments were conducted using laser powers of 85.2 mW, 59.9 mW, and 85.2 mW and pulse durations of 30 s, 45 s, and 60 s. For each trace in Fig. 1a), eleven laser pulses were applied to

¹We acknowledge financial support from the German Federal Ministry of Education and Research via the funding program quantum technologies - from basic research to the market under contract number 13N15680 "GeQCoS" and under contract number 13N16188 "MUNIQC-SC" as well as by the Deutsche Forschungsgemeinschaft (DFG, German Research Foundation) via project number FI2549/1-1 and the Germany's Excellence Strategy EXC-2111-390814868 'MCQST', as well as the Horizon Europe programme HORIZON-CL4-2022-QUANTUM-01-SGA via the project 101113946 (OpenSuperQPlus100). The research is part of the Munich Quantum Valley, which is supported by the Bavarian state government with funds from the Hightech Agenda Bayern Plus.

individual Josephson junctions. Across all tested configurations, resistance increases exceeding 10% were observed after applying eleven laser pulses. The highest resistance change was $16.81\% \pm 0.01\%$, achieved using 85.2 mW pulses with a duration of 45 s. For a transmon qubit with an initial frequency of 4.5 GHz, this corresponds to a frequency decrease of approximately -7.9% , or over -350 MHz.

To validate the impact of laser annealing on qubit frequencies at cryogenic temperatures, a chip containing six qubits was cooled in a dilution refrigerator and characterized before and after annealing. The frequency changes of the annealed qubits ranged from -60 MHz to -95.5 MHz, while an unaltered qubit on the same chip exhibited a minor frequency decrease of 9.39 MHz, consistent with typical observations at WMI (Fig. 1b)).

These results demonstrate that our laser annealing setup effectively induces permanent resistance changes, leading to measurable shifts in qubit frequencies. The correlation between resistance and frequency changes supports the potential of laser annealing as a tool for precise frequency targeting. Further statistical studies are underway to refine the annealing process and achieve higher precision.

The next phase involves targeting fixed-frequency transmon qubits to specific frequencies using laser annealing. Combined with a calibrated resistance-to-frequency correlation, this approach will enable more reliable frequency targeting in future quantum devices.

References

- [1] A. Osman, J. Fernández-Pendás, C. Warren, S. Kosen, M. Scigliuzzo, A. F. Kockum, G. Tancredi, A. F. Roudsari, and J. Bylander, *Phys. Rev. Research* **5**, 043001 (2023).
- [2] V. Ambegaokar, and A. Baratoff, *Phys. Rev. Lett.* **10**, 486 (1963).
- [3] A. Osman, J. Simon, A. Bengtsson, S. Kosen, P. Krantz, D. P. Lozano, M. Scigliuzzo, P. Delsing, J. Bylander, and A. Fadavi Roudsari, *Appl. Phys. Lett.* **118** (2021).
- [4] J. Kreikebaum, K. O'Brien, A. Morvan, and I. Siddiqi, *Supercond. Sci. Technol.* **33**, 06LT02 (2020).
- [5] J. B. Hertzberg, E. J. Zhang, S. Rosenblatt, E. Magesan, J. A. Smolin, J.-B. Yau, V. P. Adiga, M. Sandberg, M. Brink, J. M. Chow et al., *npj Quantum Information* **7**, 129 (2021).
- [6] E. J. Zhang, S. Srinivasan, N. Sundaresan, D. F. Bogorin, Y. Martin, J. B. Hertzberg, J. Timmerwilke, E. J. Pritchett, J.-B. Yau, C. Wang et al., *Sci. Adv.* **8**, eabi6690 (2022).
- [7] H. Kim, C. Jünger, A. Morvan, E. S. Barnard, W. P. Livingston, M. Altoé, Y. Kim, C. Song, L. Chen, J. M. Kreikebaum et al., *Appl. Phys. Lett.* **121** (2022).

Statistics



Honors and Awards

Hans Hübl is Appointed Adjunct Professor at TUM

The Technical University of Munich (TUM) has appointed **Dr. habil. Hans Hübl** as an Adjunct Professor in recognition of his excellent contributions to both research and teaching. Hans Hübl is a research group leader at the Walther-Meißner-Institute (WMI) of the Bavarian Academy of Sciences and Humanities (BAdW) since 2009 and a lecturer at the Technical University of Munich (TUM) since 2014. As a member of the excellence cluster Munich Center for Quantum Science and Technology (MCQST) and the Munich Quantum Valley (MQV), he makes key contributions to the successful research and teaching program in quantum science and technology.

Congratulations to Hans! We are very happy that, again, a research staff member of WMI has been honored with the award of an adjunct professorship. *“I am very pleased to see that we are very successful in fostering the scientific careers of the WMI scientists”*, the responsible group leader Rudolf Gross points out. *“This is clearly showing us that the ambitious and clearly shaped career path that we have established for WMI research staff members is an excellent way for promoting them”*, he adds. As detailed on page 105, already 10 WMI scientists received professor positions both locally and outside of Munich since 2000.

About Hans Hübl

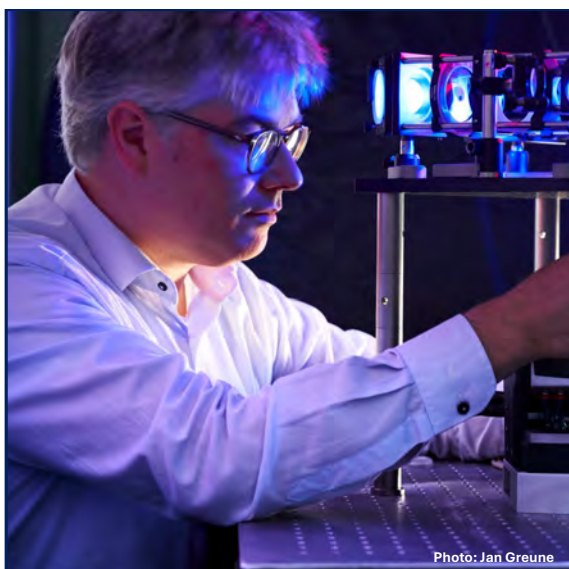

Hans Hübl received his physics education at the Technical University of Munich, where he completed his doctorate at the Walter Schottky Institute in 2007. After a stay as a postdoctoral fellow at the Centre for Quantum Computer Technology at the University of New South Wales in Sydney, Australia in 2007 and 2008, he returned to Germany in 2009 to the Walther-Meißner Institute of the Bavarian Academy of Sciences and Humanities in Garching. Starting in an initial temporary position as a research assistant, he was quickly given a permanent position there as Senior Academic Advisor and later Academic Director and Deputy Institute Director. At the Walther-Meißner-Institute, he heads an independent research group work-

ing very successfully on the topics of spin dynamics and hybrid quantum systems. He received a habilitation degree and became a lecturer in experimental physics at TUM in 2014. Since then, he has been actively involved in teaching and most recently contributed to the very successful new interdisciplinary master course in Quantum Science and Technology. In 2012, he received the Academy Prize of the Karl Thiemig Foundation, and in 2020, he was named APS outstanding referee.

A particular strength of Hans Hübl is fostering collaborations in coordinated research programs. He has been one of the key figures in several coordinated research programs in the greater Munich area for many years. From 2010 to 2015, he was Principal Investigator in the Collaborative Research Center 631 (Solid-state Based Quantum Information Processing), from

2013 to 2018 he was a member of the Cluster of Excellence “Nanosystems Initiative Munich (NIM)” and from 2019 Core PI of the Cluster of Excellence “Munich Center for Quantum Science and Technology (MCQST)”. He was also Principal Investigator of the DFG Priority Program “New Frontiers in Sensitivity for EPR Spectroscopy: From Biological Cells to Nano Materials (SPP 1601, 2015-2019)” and was or still is Principal Investigator in numerous EU research projects, e.g. in the collaborative projects (i) “Magnetomechanical Platforms for Quantum Experiments and Quantum Enabled Sensing Technologies (MaQSens, 2017-2022)”, (ii) “Exploring Nonclassical States of Center-of-Mass Mechanical Motion with Superconducting Magneto- and Levitomechanics (SuperMeQ, 2022-2026)”, or (iii) “Open Superconducting Quantum Computers (OpenSuperQPlus, 2023-2027)”. He also is a key player in several BMBF collaborative projects such as QuaMToMe. Finally, it should not go unmentioned that Hans Hübl is a central pillar of the Munich Quantum Valley (MQV) and PI at the newly approved DFG Collaborative Research Center/Transregio TRR 360 “Constrained Quantum Matter”, which started in October 2023.

For many years, Hans Hübl is considered a leading international expert in two particular subfields: (i) spin dynamics and quantum magnonics and (ii) hybrid quantum systems. He has contributed to both fields with fundamental publications and pioneering work. With the first proof of strong coherent photon-magnon coupling (*Phys. Rev. Lett.* **111**, 127003 (2013)), he established the new field of “cavity quantum magnonics”. Together with his colleagues at UNSW, he demonstrated the efficient readout of spin qubits for the first time (*Nature* **467**, 687 (2010)). Moreover, in fundamental work on circuit quantum electrodynamics, ultra-strong coupling was demonstrated for the first time (*Nature Physics* **6**, 772 (2010)). Equally important is the work on the first demonstration of the spin-Nernst effect (*Nature Materials* **16**, 977-981 (2017)), the generation of slow light in nanoelectromechanical circuits (*Nature Physics* **9**, 179 (2013)), the observation of multiple spin echoes in electron spin resonance (*Phys. Rev. Lett.* **125**, 137701 (2020)) or on the detection of the Hanle effect in antiferromagnets (*Phys. Rev. Lett.* **130**, 216703 (2023)).

Prestigious ERC Consolidator Grant Awarded to Dr. Matthias Althammer

The European Research Council (ERC) has awarded its Consolidator Grants (CoG) to 328 outstanding scientists in 25 EU Member States with a total budget of 678 million euros. Dr. Matthias Althammer, a research group leader at the Walther-Meißner-Institute (WMI) of the Bavarian Academy of Sciences and Humanities (BAdW) was awarded one of these prestigious grants. The grant allows him to implement an ambitious research project, aiming at establishing antiferromagnetic magnonics as a platform for energy-efficient information processing.

Congratulations to Matthias! *"I am very happy that Matthias was successful in this highly competitive funding scheme with a total success rate of only 14.2% in 2024",* Rudolf Gross, scientific director at WMI, says. *"This will not only provide a strong push for the antiferromagnetic magnonics research at the WMI, but also to the scientific career of Matthias",* he adds.

About the Awardee. Matthias Althammer received his PhD from Technical University of Munich in 2012, which led to the discovery of a new magnetoresistance effect, now called the spin Hall magnetoresistance. After finishing his PhD, Matthias spent a year researching spin transport effects in oxide materials at the University of Alabama, USA, in the materials for information technology center within the group of Prof. Arunava Gupta as a Postdoc. After a short stint in industry, working as an engineering consultant at BMW AG, he started his junior research group at WMI in 2015. With his research group, he spearheaded the research activities at WMI, focusing on spin transport phenomena and spin excitations in magnetic insulators and metals. In 2021, Matthias finished his Habilitation at Technical University of Munich and became a "Privatdozent" at TUM in the physics department in 2023. In addition to excellent research, Matthias has tremendously contributed to the education and development of young talents and received the 2022 PhD supervisory award from the physics department of TUM.

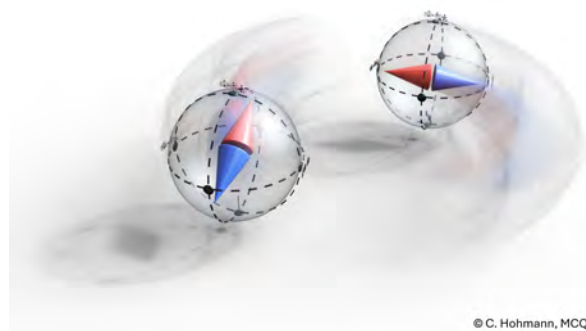

© C. Hohmann, MCQST

A Fascinating Research Proposal. In the project **"Pseudospin-based Antiferromagnetic Magnonics (POSA)"**, Matthias Althammer will address the important problem that in our information-driven society, the demand for more powerful and faster information processing systems is continuously increasing – and the same is true for the associated energy consumption. Therefore, there is an urgent need for novel approaches that allow for faster and, most importantly, more energy-efficient information processing. Today, information technology is

dominated by electronics, where the charge of the electrons is used in information processing devices. Besides its charge, electrons also possess a spin, representing an angular momentum

and being associated with a magnetic moment. This spin is an intrinsic property, which can assume two discrete states along a quantization axis, making it ideal for binary information encoding. Therefore, the spin is already routinely exploited in the research field called spintronics and successfully used for information storage in non-volatile magnetic random-access memories or magnetic hard disks. A key question is how to efficiently transport information encoded in the spin degree of freedom. Here, a promising approach is to use the quantized excitations of the magnetic lattice in electrically insulating ferromagnets or antiferromagnets, called magnons. The realization of this interesting approach is at the heart of the project POSA, which will explore the full potential of antiferromagnetic magnonics. An important goal of the project is to realize so-called antiferromagnetic spin-torque oscillators, which enable the conversion of DC charge currents into THz magnons. The unique properties of these oscillators enable their use as artificial neurons. The ultimate goal is to link these artificial neurons via magnons to realize a spiking artificial neuronal network. Implementing this concept provides the perspective to achieve a novel type of artificial neuronal network with low power consumption and fast operation speed.

Building on Excellent Research and Infrastructure Over the last few years, researchers at WMI already successfully studied antiferromagnetic insulators for their unique properties concerning spin information transport. For a ferromagnetic material, the localized magnetic moments are oriented in parallel. For an antiferromagnet, the neighboring localized magnetic moments order in an antiparallel fashion and thus exhibit no net magnetization. Although this property makes it challenging to manipulate antiferromagnets by external magnetic fields, it leads to much higher magnon frequencies to the terahertz regime in antiferromagnets. Therefore, antiferromagnetic magnonics has been studied intensively in the past decade. A unique aspect is that the magnons in antiferromagnets come in pairs with opposite chirality, that is, pairs of "spin-up" and "spin-down" magnons. In recent experiments, the research group at WMI with theory support by Prof. Akashdeep Kamra from the RPTU Kaiserslautern-Landau, showed that these two spin states can be experimentally accessed and manipulated. Matthias Althammer says: *"This is the first step towards a spin-based magnonic concept, which provides an exciting perspective for future information processing concepts. With the received funding by the ERC, we can now develop energy-efficient methods for the generation, manipulation, and detection of magnonic spin transport in antiferromagnetic insulators. A key advantage of antiferromagnetic insulators is that electron-magnon scattering is suppressed, reducing the power consumption of such devices."*

About the ERC Consolidator Grants The [ERC awards Consolidator Grants \(ERC-CoG\)](#) to established scientists with 7-12 years of experience since completion of PhD, having an outstanding scientific track record and presenting an excellent research proposal. The funding is provided through the [EU's Horizon Europe program](#). The grants, awarded up to € 2 million for a period of 5 years, are very prestigious, and unfortunately, the success rate is quite low. In the last round, only 14.2% of the total of 2313 submitted proposals have been selected for funding. Therefore, Rudolf Gross, the head of the research group, is very happy that Matthias was successful in this highly competitive funding scheme. *"The grant also can be viewed as a distinction of the excellent research conducted at the WMI and our continuous efforts to promote talented young researchers,"* he says.



Publications

- Demonstration of microwave single-shot quantum key distribution**
Florian Fesquet, Fabian Kronowetter, Michael Renger, Wun Kwan Yam, Simon Gandorfer, Kunihiro Inomata, Yasunobu Nakamura, Achim Marx, Rudolf Gross, and Kirill G. Fedorov
[Nature Communications 15, 7544 \(2024\)](#).
- Onset of transmon ionization in microwave single-photon detection**
Yuki Nojiri, Kedar E. Honasoge, Achim Marx, Kirill G. Fedorov, Rudolf Gross
[Physical Review B109, 174312 \(2024\)](#).
- Electrically Induced Angular Momentum Flow between Separated Ferromagnets**
Richard Schlitz, Matthias Grammer, Tobias Wimmer, Janine Gückelhorn, Luis Flacke, Sebastian T.B. Goennenwein, Rudolf Gross, Hans Huebl, Akashdeep Kamra, and Matthias Althammer
[Physical Review Letters 132, 256701 \(2024\)](#).
- Efficient Decoupling of a Nonlinear Qubit Mode from Its Environment**
Frederik Pfeiffer, Max Werninghaus, Christian Schweizer, Niklas Bruckmoser, Leon Koch, Niklas J. Glaser, Gerhard Huber, David Bunch, Franz X. Haslbeck, M. Knudsen, Gleb Krylov, Klaus Liegener, Achim Marx, Lea Richard, João H. Romeiro, Federico Roy, Johannes Schirk, Christian Schneider, Malay Singh, Lasse Södergren, Ivan Tsitsilin, Florian Wallner, Carlos A. Riofrío, and Stefan Filipp
[Physical Review X 14, 041007 \(2024\)](#).
- Chiral phonons and phononic birefringence in ferromagnetic metal–bulk acoustic resonator hybrids**
M. Müller, J. Weber, F. Engelhardt, V.A.S.V. Bittencourt, T. Luschmann, M. Cherkasskii, M. Opel, S.T.B. Goennenwein, S.Viola Kusminskiy, S. Geprägs, R. Gross, M. Althammer, H. Huebl
[Physical Review B 109, 024430 \(2024\)](#).
- Planar scanning probe microscopy enables vector magnetic field imaging at the nanoscale**
Paul Weinbrenner, Patricia Klar, Christian Giese, Luis Flacke, Manuel Müller, Matthias Althammer, Stephan Geprägs, Rudolf Gross, Friedemann Reinhard
[Quantum Science and Technology 10, 015037 \(2024\)](#).
- Significant modulation of Gilbert damping in ultrathin ferromagnetic films by altering the surface magnetic anisotropy**
Shugo Yoshii, Manuel Müller, Hajime Inoue, Ryo Ohshima, Matthias Althammer, Yuichiro Ando, Hans Huebl, and Masashi Shiraishi
[Physical Review B 109, L020406 \(2024\)](#).
- Temperature dependence of the magnon-phonon interaction in high-overtone bulk acoustic resonator-ferromagnetic thin film hybrids**
Manuel Müller, Johannes Weber, Sebastian T.B. Goennenwein, S. Viola Kusminskiy, Rudolf Gross, Matthias Althammer, and Hans Huebl
[Physical Review Applied 21, 034032 \(2024\)](#).
- Remote sensing of a levitated superconductor with a flux-tunable microwave cavity**
Philip Schmidt, Remi Claessen, Gerard Higgins, Joachim Hofer, Jannek J. Hansen, Peter Asenbaum, Martin Zemlicka, Kevin Uhl, Reinhold Kleiner, Rudolf Gross, Hans Huebl, Michael Trupke, and Markus Aspelmeyer
[Physical Review Applied 22, 014078 \(2024\)](#).
- Inductive noise spectroscopy of thermally excited magnons**
Luise Siegl, Richard Schlitz, Jamal Ben Youssef, Christian Runge, Akashdeep Kamra, William Legrand, Hans Huebl, Michaela Lammel, and Sebastian T. B. Goennenwein
[Physical Review Applied 22, 054036 \(2024\)](#).

11. **Slow and non-equilibrium dynamics due to electronic ferroelectricity in a strongly correlated molecular conductor**
Tatjana Thomas, Yassine Agarmani, Steffi Hartmann, Mark Kartsovnik, Natalia Kushch, Stephen M. Winter, Sebastian Schmid, Peter Lunkenheimer, Michael Lang, and Jens Müller
npj Spintronics **2**, 24 (2024).
12. **Electronic properties of the dimerized organic conductor κ -(BETS)₂Mn[N(CN)₂]₃**
Marvin Schmidt, Savita Priya, Zhijie Huang, Mark Kartsovnik, Natalia Kushch, and Martin Dressel
Physical Review B **110**, 195128 (2024).
13. **Electronic correlations and spin frustration in the molecular conductors κ -(BEDT-TTF)₂X probed by magnetic quantum oscillations**
Shamil Erkenov, Sergej Fust, Sebastian Oberbauer, Werner Biberacher, Natalia D. Kushch, Harald Müller, Francis L. Pratt, Rudolf Gross, and Mark V. Kartsovnik
Physical Review B **110**, 205149 (2024).
14. **Imperfect photon detection in quantum illumination**
F. Kronowetter, M. Würth, W. Utschick, R. Gross, K. G. Fedorov
Physical Review Applied **21**, 014007 (2024).
15. **Role of topology in compensated magnetic systems**
Helena Reichlova, Dominik Kriegner, Alexander Mook, Matthias Althammer, and Andy Thomas
APL (Applied Physical Letters) Materials **12**, 010902 (2024).
16. **Tailoring superconducting nanowire single-photon detectors for quantum technologies**
Lucio Zugliani, Christian Schmid, Fabian Wietschorke, Björn Jonas, Simone Spedicato, Stefan Strohauer, Stefanie Grotowski, Rasmus Flaschmann, Manuel Müller, Matthias Althammer, Rudolf Gross, Jonathan Finley, Kai Müller
2023 IEEE Globecom Workshops (GC Wkshps), Kuala Lumpur, Malaysia, pp. 1051-1056 (2024).
17. **Structural, electrical and magnetic properties of reactively DC sputtered Cu and Ti thin films. Application to Cu/Ti neutron supermirrors for low spin-flip applications**
Jose Manuel Gómez-Guzmán, Matthias Opel, Tamás Veres, Peter Link, László Bottyán
Nuclear Instruments and Methods in Physics Research A **1059**, 169005 (2024).
18. **Printed Thin Magnetic Films via Ternary Hybrid Diblock Copolymer Films Containing Magnetic Iron Oxide and Nickel Nanoparticles**
Christopher R. Everett, Xinyu Jiang, Manuel A. Reus, Huaying Zhong, Martin Bitsch, Martina Plank, Markus Gallei, Matthias Opel, Matthias Schwartzkopf, Stephan V. Roth, Peter Müller-Buschbaum
ACS Applied Materials & Interfaces **16**, 71060-71069 (2024).
19. **Toward high-fidelity quantum information processing and quantum simulation with spin qubits and phonons**
Inigo Arrazola, Yuri Minoguchi, Marc-Antoine Lemonde, Alp Sipahigil, Peter Rabl
Physical Review B **110**, 045419 (2024).
20. **The bosonic skin effect: boundary condensation in asymmetric transport**
Louis Garbe, Yuri Minoguchi, Julian Huber, Peter Rabl
SciPost Physics **16**, 029 (2024).
21. **Topological dynamics of adiabatic cat states**
Jacquelin Luneau, Benoit Douçot, David Carpentier
SciPost Physics **17**, 112 (2024).
22. **Single-Crystalline YIG Nanoflakes with Uniaxial In-Plane Anisotropy and Diverse Crystallographic Orientations**

- Roman Hartmann, Seema, Ivan Soldatov, Michael Lammel, Daphné Lignon, Xianyue Ai, Gillian Kiliani, Rudolf Schäfer, Andreas Erb, Rudolf Gross, Johannes Boneberg, Martina Müller, Sebastian T. B. Goennenwein, Elke Scheer, Angelo Di Bernardo
APL Materials **12**, 031121 (2024).
23. **Solving quantum chemistry problems on quantum computers**
Klaus Liegener, Oliver Morsch, Guido Pupillo
Physics Today **77**, 34 (2024).
 24. **Double TES detectors to investigate the CRESST low energy background: results from above-ground prototypes**
G. Angloher, A. Erb *et al.*, CRESST Collaboration
European Physical Journal C **84**, 1227 (2024).
 25. **Constraints on self-interaction cross-sections of dark matter in universal bound states from direct detection**
G. Angloher, A. Erb *et al.*, CRESST Collaboration
European Physical Journal C **84**, 1170 (2024).
 26. **First observation of single photons in a CRESST detector and new dark matter exclusion limits**
G. Angloher, A. Erb *et al.*, CRESST Collaboration
Physical Review D **110**, 083038 (2024).
 27. **Double TES detectors to investigate the CRESST low energy background: results from above-ground prototypes**
G. Angloher, A. Erb *et al.*, CRESST Collaboration
European Physical Journal C **84**, 1001 (2024).
 28. **A likelihood framework for cryogenic scintillating calorimeters used in the CRESST dark matter search**
G. Angloher, A. Erb *et al.*, CRESST Collaboration
European Physical Journal C **84**, 922 (2024).
 29. **Detector Development for the CRESST Experiment**
G. Angloher, A. Erb *et al.*, CRESST Collaboration
Journal of Low Temperature Physics **216**, 393-401 (2024).
 30. **Light dark matter search using a diamond cryogenic detector**
G. Angloher, A. Erb *et al.*, CRESST Collaboration
European Physical Journal C **84**, 324 (2024).
 31. **Optimizing the growth condition of MoSi thin films for single-photon detection**
Stefanie Grotowski, Lucio Zugliani, Björn Jonas, Rasmus Flaschmann, Christian Schmid, Stefan Strothauer, Fabian Wietschorke, Niklas Bruckmoser, Matthias Althammer, Rudolf Gross, Kai Müller, Jonathan Finley
Scientific Reports **15**, 2438 (2025).
 32. **Two-Dimensional Planck Spectroscopy**
S. Gandorfer, M. Renger, W. K. Yam, F. Fesquet, A. Marx, R. Gross, K. G. Fedorov
arXiv:2308.02389, submitted for publication (2023).
 33. **Cryogenic Microwave Link for Quantum Local Area Networks**
M. Renger, S. Gandorfer, W. Yam, F. Fesquet, M. Handschuh, K. E. Honasoge, F. Kronowetter, Y. Nojiri, M. Partanen, M. Pfeiffer, H. van der Vliet, A. J. Matthews, J. Govenius, R. N. Jabdaraghi, M. Prunnila, A. Marx, F. Deppe, R. Gross, K. G. Fedorov
arXiv:2308.12398, submitted for publication (2023).

34. **Parametric multi-element coupling architecture for coherent and dissipative control of superconducting qubits**
G. B. P. Huber, F. A. Roy, L. Koch, I. Tsitsilin, J. Schirk, N. J. Glaser, N. Bruckmoser, C. Schweizer, J. Romeiro, G. Krylov, M. Singh, F. X. Haslbeck, M. Knudsen, A. Marx, F. Pfeiffer, C. Schneider, F. Wallner, D. Bunch, L. Richard, L. Södergren, K. Liegener, M. Werninghaus, S. Filipp
[arXiv:2403.02203 \(2024\)](#).
35. **Sensitivity-Adapted Closed-Loop Optimization for High-Fidelity Controlled-Z Gates in Superconducting Qubits**
N. J. Glaser, F. A. Roy, I. Tsitsilin, L. Koch, N. Bruckmoser, J. Schirk, J. Romeiro, G. B. P. Huber, F. Wallner, M. Singh, G. Krylov, A. Marx, L. Södergren, C. Schneider, M. Werninghaus, S. Filipp
[arXiv:2412.17454 \(2024\)](#).
36. **Parity-dependent state transfer for direct entanglement generation**
Federico A. Roy, João H. Romeiro, Leon Koch, Ivan Tsitsilin, Johannes Schirk, Niklas J. Glaser, Niklas Bruckmoser, Malay Singh, Franz X. Haslbeck, Gerhard B. P. Huber, Gleb Krylov, Achim Marx, Frederik Pfeiffer, Christian M. F. Schneider, Christian Schweizer, Florian Wallner, David Bunch, Lea Richard, Lasse Södergren, Klaus Liegener, Max Werninghaus, and Stefan Filipp
[arXiv:2405.19408 \(2024\)](#).
37. **Cavity-Enhanced Optical Manipulation of Antiferromagnetic Magnon-Pairs**
Tahere S. Parvini, Anna-Luisa E. Romling, Sanchar Sharma, Silvia Viola Kusminskiy
[arXiv:2409.10659 \(2024\)](#).
38. **Protected Fluxonium Control with Sub-harmonic Parametric Driving**
Johannes Schirk, Florian Wallner, Longxiang Huang, Ivan Tsitsilin, Niklas Bruckmoser, Leon Koch, David Bunch, Niklas J. Glaser, Gerhard B. P. Huber, Martin Knudsen, Gleb Krylov, Achim Marx, Frederik Pfeiffer, Lea Richard, Federico A. Roy, João H. Romeiro, Malay Singh, Lasse Södergren, Etienne Dionis, Dominique Sugny, Max Werninghaus, Klaus Liegener, Christian M. F. Schneider, and Stefan Filipp
[arXiv:2410.00495 \(2024\)](#).
39. **Robust multi-mode superconducting qubit designed with evolutionary algorithms**
P. García-Azorín, F. A. Cárdenas-López, G. B. P. Huber, G. Romero, M. Werninghaus, F. Motzoi, S. Filipp, M. Sanz
[arXiv:2407.18895 \(2024\)](#).
40. **Mapping of a many-qubit state onto an oscillator using controlled displacements**
Anders J. E. Bjerrum, Ulrik L. Andersen, Peter Rabl
[arXiv:2410.22385 \(2024\)](#).
41. **Fabrication of low-loss Josephson parametric devices**
K. E. Honasoge, M. Handschuh, W. K. Yam, S. Gandorfer, D. Bazulin, N. Bruckmoser, L. Koch, A. Marx, R. Gross, K. G. Fedorov
[arXiv:2412.11280, submitted for publication \(2024\)](#).
42. **Broadband electron paramagnetic resonance spectroscopy of $^{167}\text{Er}:\text{}^7\text{LiYF}_4$ at mK temperatures**
Ana Strinic, Patricia Oehrl, Achim Marx, Pavel A. Bushev, Hans Huebl, Rudolf Gross, Nadezhda Kukharchyk
[arXiv:2501.04657, submitted for publication \(2025\)](#).
43. **Determining the mechanical properties of AlN films using micromechanical membranes**
Timo Sommer, Aditya, Rudolf Gross, Matthias Althammer, Menno Poot
Applied Physics Letters, accepted for publication (2024)
44. **Aufbruch ins Quantenzeitalter**
R. Gross, A. Reiserer, E. Weig
TUM Campus 1, 6-12 (2024).

The number of citations of WMI publications has steadily increased and has about quadrupled over the past two decades. In the latest statistics from the IS Web of Science, we currently observe a saturation of this trend. This, however, is mainly attributed to a gradual phase-out of the Gross group over the past years, along with the ramp-up of the Philipp and Rabl groups, who only contribute with their recent publications to this statistics.

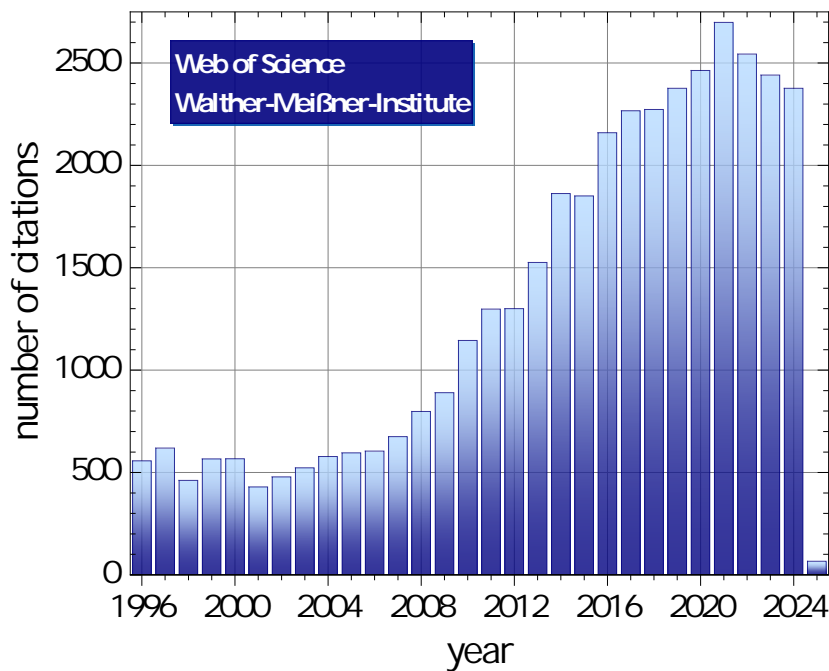

The total number of citations per year of papers published by members of WMI since 1996. This number has almost quadrupled within the last twenty years.

Books

The New Gerthsen Physik

There is a fundamentally revised version of the textbook **Gerthsen Physik**. **Rudolf Gross** of WMI joined the team of authors and contributed the part on solid-state physics.

The **Gerthsen Physik** is one of the best-known German-language physics textbooks. It roughly covers the material of the compulsory experimental physics lectures of a physics degree course, with a focus on the basic lectures of the first semesters.

The Gerthsen is an indispensable and competent companion for students of physics as a major or minor subject throughout their studies. The book presents all classical topics - mechanics, thermodynamics, electrodynamics, optics. Subsequent topics of classical physics, such as non-linear dynamics and the theory of relativity, are integrated in a logical sequence. After a chapter on particles and waves to introduce microscopic physics, the consequences for atoms, molecules, lasers, solid bodies, and subatomic particles are presented.

The first edition of the book appeared already in 1948, based on transcripts of Gerthsen's lectures at the Humboldt University in Berlin in 1946/47. After Gerthsen's death in 1956, Hans Otto Kneser took over the editorship from the 5th edition in 1958, followed by Helmut Vogel (Gerthsen-Kneser-Vogel) from the 12th edition in 1974, who also published an additional volume with the solutions to the exercises from Gerthsen (*Probleme aus der Physik*, Springer, 13th edition 1977). Since the 21st edition in 2002, the editor has been Dieter Meschede. The latest, 25th edition was published in 2015.

In the most recent editions, the **Gerthsen Physik** has only been changed minorly. Therefore, the time was now ripe for a major revision both in content and style to make the work ready for the future. Rudolf Gross of WMI agreed to join this ambitious project by contributing the chapter on solid-state physics. After many years of hard work, the New Gerthsen Physik is now ready and will become available in 2025. In writing the book chapters, the authors put particular emphasis on (i) the quick retrieval of important content, (ii) a clear, recurring structure, (iii) a clear, simple language, and (iv) detailed, comprehensible derivations. By using recurring structural elements in the different chapters, the New Gerthsen Physik aims to create a sense of regularity and makes the book appear to be a unified whole. The style of the book will be close to the Springer textbook on **Theoretische Physik** by Matthias Bartelmann, Björn Feuerbacher, Timm Krüger, Dieter Lüst, Anton Rebhan, and Andreas Wipf.

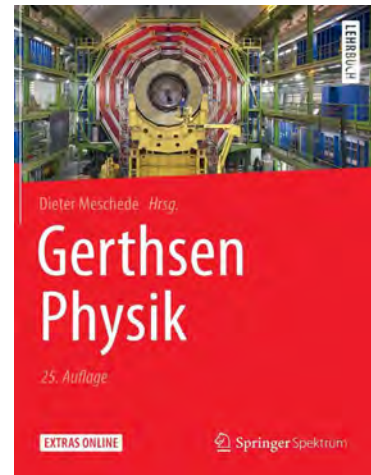

Bachelor, Master, Doctoral, and Habilitation Theses

A. Completed and Ongoing Habilitation Theses

WMI strongly supports habilitation candidates, as fostering young scholars is one of its key concerns. The habilitation process serves as the formal assessment tool ascertaining whether or not a candidate is suitable, from an academic and a pedagogical point of view, to be a professor in a particular field at the university level. Within the past 25 years, 10 research staff members of WMI completed the habilitation procedure and received the «**venia legendi**» of the Technical University of Munich (TUM). Overall, the habilitation procedure is still a valuable way of fostering young talents and WMI is quite successful in supporting young talents along this career path.



The ambitious and clearly shaped career path for WMI research staff members not only led to their successful habilitation but also to the fact that several members of WMI received professor positions both locally and outside of Munich since 2000:

1. Prof. Dr. Lambert Alff (W3 Professor, TU Darmstadt)
2. Prof. Dr. Dietrich Einzel (apl. Professor, Technische Universität München)
3. Prof. Dr. Andreas Erb (Honorarprofessor, Universität Leipzig)
4. Prof. Dr. Sebastian Gönnenwein (W3 Professor, Universität Konstanz)
5. Prof. Dr. Rudolf Hackl (apl. Professor, Technische Universität München)
6. Prof. Dr. Hans Hübl (apl. Professor, Technische Universität München)
7. Prof. Dr. Anton Lerf (apl. Professor, Technische Universität München)
8. Prof. Dr. Matteo Mariantoni (Associate Professor, University of Waterloo, Canada)
9. Prof. Dr. Erwin Schubert (apl. Professor, Technische Universität München)
10. Prof. Dr. Mathias Weiler (W3 Professor, RPTU Kaiserslautern-Landau)

The last one was Hans Hübl, who was appointed Adjunct Professor at TUM in 2024 (see page 95). Most likely, the next one will be Matthias Althammer, who was awarded an ERC Consolidator Grant in 2024 (see page 97).

It is important to note that members of the WMI research team not only are successful in promoting their scientific careers but also take leading positions in the industry. Prominent examples are [Jan Goetz](#), the co-founder of the start-up IQM Quantum Computers, who was a member of the Gross group between 2011 and 2017, or [Frank Deppe](#), who did his habilitation thesis at WMI and now is Head of QPU Technology at IQM Quantum Computers.

Dr. Nadezhda Kukharchyk

Supporting and mentoring talented female scientists in natural sciences and engineering is an important long-term task. This is particularly true for quantum sciences where the share of female scientists is still much too low, particularly at the postdoc and professor levels. Therefore, WMI is happy to have a female group leader who is presently passing the habilitation procedure.

Nadezhda Kukharchyk received one of the prestigious *START Fellowships* of the Excellence Cluster MCQST in 2020. Supported by this fellowship, she joined the group of Rudolf Gross at WMI in November 2020 and built up a new research group at WMI focusing on the spectroscopy and applications of spin-based quantum systems. In November 2021, she presented her research field and recent achievements to the Faculty of Physics teaching body within the Solid-State Colloquium. After this formal step, she submitted the required documents to the dean's office and was then accepted as a habilitation candidate by the School of Natural Sciences of TUM early in 2022. Her *Fachmentorat* consists of Rudolf Gross (WMI/BAdW and TUM, chairman), Jonathan Finley (TU Munich/Walter Schottky Institute, member), and Klaus Mølmer (Niels Bohr Institute, University of Copenhagen, Denmark, member).



Nadezhda Kukharchyk studied physics at the Belarussian State University in Minsk, Belarus, and then joined the University of Bochum (group of Prof. Andreas Wieck) as a Ph.D. student in 2011. She finished her thesis entitled *Focused Ion-Beam Implantation of Rare-Earth Ions for Realisation of Spin-Ensemble Systems* in 2015. She then joined Saarland University, where she was setting up a newly established experimental laboratory for optical and microwave spectroscopy of rare-earth doped single crystals at mK temperatures before accepting the MCQST offer and joining the group of Rudolf Gross at WMI. We are very happy to be able to support the scientific career of an ambitious female researcher.

Meanwhile, Nadezhda Kukharchyk already acquired a new BMBF-project on the *Storage of Microwave Quantum Tokens in Electron and Nuclear Spin Ensembles (QuaMToMe)*, grant No. 16 KISQ 036). She is the coordinator of this new project, which started in November 2021. The core objective of QuaMToMe is the realization, investigation, and demonstration of quantum tokens (Q-tokens) in the microwave or GHz frequency range. The quantum tokens will be implemented in the form of quantum keys stored in quantum memories based on spin ensembles. In general, scalable and long-lived quantum memories represent one of the missing elements needed to build local microwave-based quantum networks. Quantum tokens in the form of propagating squeezed states represent a particularly important use case for such quantum networks.

B. Completed and Ongoing Ph.D. Theses

Completed Ph.D. Theses:

1. **A Journey into Quantum Illumination**
Fabian Kronowetter, Technical University of Munich, May 2024.
2. **Hybrid Solid State Quantum Systems**
Thomas Luschmann, Technical University of Munich, June 2024.
3. **Onset of Transmon Ionization in Microwave Single-Photon Detection**
Yuki Nojiri, Technical University of Munich, October 2024.

Ongoing Ph.D. Theses:

1. **Operation and Modelling of Superconducting Qubit Devices**
Federico Roy, Saarland University, since September 2018.
2. **Fabrication and Investigation of Superconducting Quantum Processors with Novel Architectures**
Leon Koch, Technical University of Munich, since July 2020.
3. **Tailoring the Control of Superconducting Qubits to Efficiently Solve Molecular Chemistry Problems**
Malay Singh, Technical University of Munich, since October 2020.
4. **Design and Assembly of Superconducting Quantum Processors in Different Frequency Ranges**
Ivan Tsitsilin, Technical University of Munich, since November 2020.
5. **Fabrication and Characterization of Superconducting Parametric Devices**
Kedar Honasoge, Technical University of Munich, since February 2021.
6. **Demonstration of Microwave Quantum Key Distribution**
Florian Fesquet, Technical University of Munich, since February 2021.
7. **Providing external access to a superconducting quantum processor**
Martin Knudsen, Technical University of Munich, since March 2021.
8. **Implementation of Optical Approaches in Microwave Quantum Memory Systems**
Ana Strinic, Technical University of Munich, since April 2021.
9. **Josephson Travelling Wave Parametric Amplifier for Multi-qubit Readout**
Daniil Bazulin, Technical University of Munich, since August 2021.
10. **Evolution of the Charge Carrier Properties and Electronic Correlations in Layered Organic Metals near the Mott Metal-Insulator Transition**
Shamil Erkenov, Technical University of Munich, since September 2021.
11. **Industry-compatible development of Travelling Wave Parametric Amplifiers**
Nicolas Arlt, Technical University of Munich, since Oktober 2021.
12. **Hardware-tailored Quantum algorithms with Superconducting Qubits**
Frederik Pfeiffer, Technical University of Munich, since November 2021.
13. **Scalable Multi-Qubit Architectures Based on Superconducting Qubits**
Niklas Glaser, Technical University of Munich, since December 2021.
14. **Design and Application of Multi-Qubit Couplers**
Gerhard Huber, Technical University of Munich, since December 2021.

15. **Scalable quantum processor with novel superconducting qubits**
Florian Wallner, Technical University of Munich, since January 2022.
16. **Experimental Realization of Quantum Memory Based on Phosphorous Donors in Silicon Including Storage and Retrieval of Q-Tokens**
Patricia Oehrl, Technical University of Munich, since February 2022.
17. **Fabrication and Characterization of Thin Films and Heterostructures of Quantum Materials**
Monika Scheufele, Technical University of Munich, since April 2022.
18. **Fabrication and Characterization of Superconducting Single Photon Detectors**
Maria Handschuch, Technical University of Munich, since April 2022.
19. **Towards high coherence 3D integrated superconducting quantum circuits**
Lea Richard, Technical University of Munich, since June 2022.
20. **Materials optimization and nanofabrication techniques for the scaling up of superconducting quantum processors**
David Bunch, Technical University of Munich, since June 2022.
21. **Scalable control for superconducting qubits**
João Romeiro, Technical University of Munich, since July 2022.
22. **Quantum information processing based on alternative superconducting qubits**
Johannes Schirk, Technical University of Munich, since July 2022.
23. **Quantum Gravity – Levitated Superconductors and their Position Measurement**
Korbinian Rubenbauer, Technical University of Munich, since October 2022.
24. **Entanglement distribution with continuous and discrete variable systems**
Joan Agustí, Technical University of Munich, since November 2022.
25. **Microwave Quantum Communication over Thermal Channels**
Wun Kwan Yam, Technical University of Munich, since November 2022.
26. **Remote entanglement of superconducting qubits**
Simon Gandorfer, Technical University of Munich, since January 2023.
27. **Tailored Magneto-Mechanical Hybrids for Quantum Transduction**
Matthias Grammer, Technical University of Munich, since March 2023.
28. **Investigating the Origin of Decoherence in Superconducting Qubits**
Niklas Bruckmoser, Technical University of Munich, since April 2023.
29. **Optimal control of quantum communication protocols**
Przemyslaw Zielinski, Technical University of Munich, since April 2023.
30. **Industry-compatible development of superconducting qubits**
Karina Houska, Technical University of Munich, since April 2023.
31. **Fabrication of reproducible Josephson junctions for superconducting quantum processors**
Julius Feigl, Technical University of Munich, since May 2024.
32. **Storage of Microwave-Based Quantum Tokens in Rare-Earth Spin Ensembles in CaWO₄ Single Crystals**
Georg Mair, Technical University of Munich, since July 2023.
33. **Protected light-matter interfaces in hybrid quantum networks**
Syeda Aliya Batool, Technical University of Munich, since September 2023.
34. **Development of a scalable readout and control system for superconducting qubits**

- Kevin Kiener, Technical University of Munich, since September 2023.
35. **Noise informed optimal control for superconducting hardware**
Emily Wright, Technical University of Munich, since October 2023.
 36. **Waveguide QED systems with interacting photons**
Adrian Misselwitz, Technical University of Munich, since October 2023.
 37. **Quantum simulations of lattice gauge theories**
Lucia Valor, Technical University of Munich, since October 2023.
 38. **Magnetic Resonance Spectroscopy of Quantum Materials**
Johannes Weber, Technical University of Munich, starts in January 2024.
 39. **Multi-quantumprocessor architectures based on superconducting qubits**
Saya Schöbe, Technical University of Munich, since March 2024.
 40. **Dissipative quantum many-body physics using photons**
Lukas Schamriß, Technical University of Munich, since April 2024.
 41. **Vacuum correlations in engineered photonic and phononic systems**
Gesa Dünneweber, Technical University of Munich, since October 2024.
 42. **Optimization of readout methods for superconducting quantum bits and quantum processors**
Julian Englhardt, Technical University of Munich, since October 2024.
 43. **Quantum interfaces with spins and phonons**
Philippe Gigon, Technical University of Munich, since November 2024.

C. Completed and Ongoing Bachelor and Master Theses

Completed Master Theses:

1. **Multiplexed Digital Readout of Superconducting Qubits using Josephson Photomultiplier**
Jan Glenn Wozniak, Technical University of Munich, February 2024.
2. **Frequency Tuning of Superconducting Qubits by Laser Annealing of Josephson Junctions**
Julius Feigl, Technical University of Munich, February 2024.
3. **Optimization of Parameterized Quantum Circuits on Superconducting Qubits**
Florian Maier, Technical University of Munich, February 2024.
4. **Micromagnetic simulation of nanogratings as possible devices for unidirectional spin wave propagation**
Markus Kügler, Technical University of Munich, July 2024.
5. **A Quantum Software Experimentation Interface to a Superconducting Quantum Computer**
Teodor-Adrian Mihaescu, Technical University of Munich, July 2024.
6. **Critically Coupled Qubit-Photon Interfaces in Waveguide QED**
Nicolas Jungwirth, Technical University of Munich, September 2024.
7. **Charge Noise Characterization on Superconducting Qubits**
Julian Enghardt, Technical University of Munich, September 2024.
8. **Fabrication of a resonating superconducting coplanar transmission line for efficient coupling to rare earth spin ensembles**
Chiun Fu, Technical University of Munich, October 2024.
9. **Broadband Josephson Parametric Amplifier**
Diego Contreras, Technical University of Munich, November 2024.
10. **Microwave Cryptography with Propagating Quantum Tokens**
Longxiang Huang, Technical University of Munich, November 2024.
11. **Investigation of a Concept for a Magnetic Annealing Oven for Applications in MRAM and other GMR, TMR Effect Devices**
Muhammad Usama Akbar, Technical University of Munich, November 2024.
12. **Stochastic Simulation of Dissipative Spin Systems**
Aristo P, Technical University of Munich, December 2024.

Completed Bachelor Theses:

1. **Charakterisierung des Magnontransports in dünnen α -Fe₂O₃ Schichten sowie Einfluss der Titandotierung auf deren strukturelle und magnetische Eigenschaften**
Tobias Herrlich, Technical University of Munich, September 2024.
2. **Angular Magnetotransport Between Isolated Ferromagnetic Nanostructures**
Michael Lehotkay, Technical University of Munich, September 2024.
3. **Broadband Electron Spin Resonance Spectroscopy of Ytterbium-171 Spins in Y₂SiO₅**
Leevi Lehto, Technical University of Munich, September 2024.
4. **Variational Unitary Coupled Cluster on the Fermi-Hubbard Model**
Petrit Dauti, Technical University of Munich, September 2024.

5. **Variational Quantum Eigensolver with Zero Noise Extrapolation**
Alexander Glas, Technical University of Munich, September 2024.
6. **Comparing Quantum Multiplication Algorithms**
Till Nemolcev, Technical University of Munich, September 2024.
7. **Magnetostatic Modes in Yttrium Iron Garnet and Nickel Zink Ferrite Spheres**
Wendelin Mayer, Technical University of Munich, October 2024.
8. **Design and Simulation of a Frequency Tunable 3D Cavity for Cat State Generation**
Niklas Walter, Technical University of Munich, October 2024.
9. **Charakterisierung des Magnontransports in dünnen α -Fe₂O₃ Schichten sowie Einfluss der Titandotierung auf deren strukturelle und magnetische Eigenschaften**
Tobias Herrlich, Technical University of Munich, October 2024.
10. **Simulating the 1-Vertex Model of SU(2) Lattice Gauge Theory on Near Term Quantum Computers**
Dominik Mattern, University of Munich, October 2024.
11. **Development of Superconducting On-Chip Low-Pass Filters for Protection of Fluxonium Qubits**
Niklas Hellriegel, Technical University of Munich, October 2024.
12. **Dynamics of Spin Relaxation in Concentrated Ho:LiYF₄ in the Vicinity of Spin-Flip Point**
Michel Wonneberger, Technical University of Munich, November 2024.
13. **Characterization of Aluminum-based Nanomechanical String Resonators for Nonlinear Nano-electromechanical Quantum Circuits**
Isabella Sachsenhauser, Technical University of Munich, December 2024.

Ongoing Master Theses:

1. **Low loss capacitances for novel quantum processing units**
Christian Gndt, Technical University of Munich, since April 2024.
2. **Strategies for solving the Fermi-Hubbard model on near-term quantum computers**
Philipp Schulze-Hagen, Technical University of Munich, since April 2024.
3. **Quantum secret sharing with non-Gaussian states**
Karolina Weber, Technical University of Munich, since May 2024.
4. **Exploring the Potential of Hybrid Classical-Quantum Cloud Computing: Architecture, Protocol, and Performance**
Maxime Lavocat, Technical University of Munich, since June 2023.
5. **Stochastic Simulations of Transport in Quantum Spin Systems**
Franz Pöschl, Technical University of Munich, since June 2024.
6. **Quantum Correlations in Spin Lattices driven by Squeezed Light**
Arthur Butorev, Technical University of Munich, since August 2024.
7. **Investigating Decoherence in Fluxonium Qubits**
Vincent Koch, Technical University of Munich, since October 2023.
8. **Multiple-Excitation Dynamics in Spin Rings**
Lukas Vetter, Technical University of Munich, since October 2023.
9. **Alternative qubit readout using multi-mode superconducting circuits**
Rui Wang, Technical University of Munich, since October 2023.

10. **Molecular beam epitaxial growth of magnetic topological insulators**
Aenas Leingärtner-Goth, Technical University of Munich, since October 2023.
11. **Improving the signal to noise ratio of multiplexed qubit readout**
Benedikt Lezius, Technical University of Munich, since November 2023.
12. **Flip-chip indium bump bonding optimization for high coherence 3D integrated quantum circuits**
Agata Skoczylas, Technical University of Munich, since November 2023.
13. **Development of Air Bridges for Scalable Superconducting Processors**
Amanda Scoles, Technical University of Munich, since November 2024.
14. **Simulation of Lattice Gauge Theory using superconducting qubits**
Axel Karger, Technical University of Munich, since November 2024.
15. **Noise Simulations of VQE Algorithms for Lattice Gauge Theory using superconducting qubits**
Lisa Krüger, Technical University of Munich, since November 2024.
16. **Improving Coherence of Single Fluxonium Qubits by Design Optimizations**
Matthias Zetzl, Technical University of Munich, since November 2024.
17. **Towards Practical Flux Pumped Josephson Traveling Wave Parametric Amplifier**
Lars Aaron Anhalt, Technical University of Munich, since November 2024.
18. **Evaluating Spin Ensembles Based on Phosphorus Donors for Quantum Memory Applications**
Anreas Duanev, Technical University of Munich, since November 2024.
19. **Quantum State Generation in the Mechanical Domain: From Materials to Circuits**
Burak Eray Bülbüloğlu, Technical University of Munich, since December 2024.
20. **Fabrication and physical properties of Bi_2Te_3 thin films**
Aeneas Leingärtner-Goth, Technical University of Munich, December 2024.
21. **Angular momentum transport between isolated ferromagnetic strings**
Fiona Sosa, Technical University of Munich, since November 2024.
22. **Superconductor-magnetically ordered conductor heterostructures**
Timur Zeisler, Technical University of Munich, since November 2024.
23. **Positive Tensor Network Simulations of the Driven-Dissipative Bose-Hubbard Model**
Xianrui Yin, Technical University of Munich, since December 2023.

Research Projects

A large number of our research projects are benefiting from the collaboration with other research institutions and industry in coordinated research projects, as well as from individual collaborations, exchange programs and visitors. Most collaborations are based on joint projects, which are funded by different funding agencies (see list below). A considerable number of collaborations also exists with universities, other research institutions and industry without direct financial support.

A. German Research Foundation: Excellence Initiative & Strategy

Cluster of Excellence Munich Center for Quantum Science and Technology (MCQST)

The new Cluster of Excellence has been granted in September 2018 within Germany's Excellence Strategy and started in January 2019. Together with Immanuel Bloch of LMU Munich and Ignacio Cirac of Max Planck Institute of Quantum Optics, Rudolf Gross of Walther-Meißner-Institute is one of the three spokespersons of MCQST and coordinator of the Research Unit C on Quantum Computing.

1. Research Unit C: *Quantum Computing*
Principal Investigators: F. Deppe, S. Filipp, R. Gross
Contributing Researchers: K. Fedorov, A. Marx
2. Research Unit D: *Quantum Communication*
Principal Investigators: F. Deppe, S. Filipp, R. Gross
Contributing Researchers: K. Fedorov, A. Marx, N. Kukharchyk
3. Research Unit E: *Quantum Sensing*
Principal Investigators: F. Deppe, H. Hübl, R. Gross
Contributing Researchers: K. Fedorov, A. Marx, N. Kukharchyk
4. Research Unit F: *Quantum Matter*
Principal Investigators: H. Hübl, R. Gross
Contributing Researchers: M. Althammer, S. Geprägs, M. Opel

B. German Research Foundation: Collaborative Research Centers

Transregional Collaborative Research Center TRR 360: *Constrained Quantum Matter (Con-QuMat)*

1. Project C3: *Dynamically Driven Quantum Correlations*
Principal Investigators: H. Hübl, Ch. Pfeleiderer, M. Wilde
project period: 10/2023 – 09/2027

D. German Research Foundation: Research Projects

1. Project **STAQS**: *Shortcuts to Adiabaticity for Quantum Computation and Simulation*, within the QuantERA II ERA-NET Cofund in Quantum Technologies.
A. Marx, with F. Deppe, K. Fedorov, R. Gross, (Az. DE 3444/1-1)
project period: 01/2022 – 12/2024.

2. Project: *Evolution of the Charge Carrier Properties and Electronic Correlations in Layered Organic Metals near the Mott Metal-Insulator Transition*.
M. Kartsovnik, R. Gross (Az. KA 1652/5-1 and GR 1132/19-1)
project period: 07/2021 – 11/2024.
3. Project: *Multi-qubit Gates for the Efficient Exploration of Hilbert Space with Superconducting Qubit Systems*
S. Filipp (Az. FI 2549/1-1)
project period: 03/2022 – 02/2025.
4. Project: *Waveguide QED with Interacting Photons*
P. Rabl, (Az. RA 2138/2-1, Projektnummer: 522216022)
project period: 03/2023 – 02/2026.

E. European Union

1. ERC Consolidator Grant **POSA**
(call identifier: ERC-2024-COG-HORIZON-ERC),
project title: *Pseudospin-based Antiferromagnetic Magnonics*
M. Althammer, Grant Agreement No. 101171325
project period: 01/2025 – 12/2029.
2. EU Collaborative Project **SuperMeQ**
(call identifier HORIZON-CL4-2021-Digital-Emerging-02),
project title: *Exploring Non-classical States of Center-of-Mass Mechanical Motion with Superconducting Magneto- and Levitomechanics*
H. Hübl, A. Marx, Grant Agreement No. 101080143
project coordination: Chalmers University of Technology, partners: WMI/BAdW, OeAW, KIT, UAB.
project period: 10/2022 – 09/2026
3. EU Flagship Specific Grant Agreement (SGA) Project **OpenSuperQPlus100**
(call identifier HORIZON-CL4-2022-QUANTUM-01-SGA),
project title: *Open Superconducting Quantum Computers*
S. Filipp, H. Hübl, Grant Agreement No. 101113946.
partners: several European Universities and research facilities.
project period: 03/2023 – 09/2026
4. EU Flagship Framework Partnership Agreement (FPA) Project **OpenSuperQPlus**
(call identifier HORIZON-CL4-2021-DIGITAL-EMERGING-02-15),
project title: *Open Superconducting Quantum Computers*
S. Filipp, H. Hübl, Grant Agreement No. 101080139.
partners: several European Universities and research facilities.
project period: 03/2023 – 02/2027
5. EU Innovative Training Network **MOQS**
(call identifier H2020-MSCA-ITN-2020),
project title: *MOlecular Quantum Simulations*
S. Filipp, Grant Agreement No. 955479
partners: several European Universities and research facilities.
project period: 11/2020 – 10/2024
6. EU MSCA Cofund Action **QUSTEC**
(call identifier H2020-MSCA-COFUND-2018),
project title: *Quantum Science and Technologies at the European Campus*

S. Filipp, Grant Agreement 847471
 partners: several European Universities and research facilities.
 project period: 03/2019 – 07/2025

F. Bundesministerium für Bildung, Wissenschaft, Forschung und Technologie

1. Coordinated Project **QuantumSPICE**: *Quantum Superconducting Process Innovation with Characterization Enhancement* ,
 project number: 13N17044
 project part: *Optimization, Scaling and Reproducibility*
 project coordinator: F. Kalleder (Infineon)
 principal investigators of WMI: V. Bader, L. Södergren
 project partners: Infineon Technologies AG, kiutra GmbH.
 project period: 11/2024 – 10/2027.
2. Coordinated Project **MUNIQC-SC**: *Munich Quantum Valley Quantum Computer Demonstrators - Superconducting Qubits* ,
 project number: 13N16188
 project part: *Systemoptimierung und -integration*
 project coordinator: S. Filipp (TUM/WMI)
 project management: K. Liegener
 principal investigators of WMI: C. Schneider, L. Södergren, M. Werninghaus
 project partners: TUM, Fraunhofer-Gesellschaft, FAU Erlangen-Nürnberg, Infineon Technologies AG, IHP GmbH - Innovations for High Performance Microelectronics/Leibniz-Institut für innovative Mikroelektronik, IQM Germany GmbH, kiutra GmbH, Parity Quantum Computing Germany GmbH, Forschungszentrum Jülich GmbH, Zurich Instruments Germany GmbH.
 project period: 01/2022 – 12/2026.
3. Coordinated Project **QuaMToMe**: *Storage of Microwave Quantum Tokens in Electron and Nuclear Spin Ensembles*,
 project number: 16KISQ036
 project coordinator: N. Kukharchyk (WMI)
 principal investigators of WMI: K. Fedorov, R. Gross, H. Huebl, N. Kukharchyk.
 project period: 11/2021 – 04/2025.
4. Coordinated Project **QUARATE**: *QUAnten RAdar TEam* ,
 project number: 13N15380,
 project part: *Superconducting Circuits and Quantum Microwaves for Quantum Radar*,
 project coordinator: Rohde & Schwarz GmbH & Co. KG,
 principal investigators of WMI: F. Deppe, K. Fedorov, S. Filipp, R. Gross, A. Marx,
 project partners: German Aerospace Center (DLR), Technical University of Munich
 project period: 02/2021 – 01/2024.
5. Coordinated Project **GeQCoS**: *German Quantum Computer based on Superconducting Qubits*,
 project number: 13N15680
 project part: *Scaling and Demonstrator*,
 project coordinator: S. Filipp (WMI)
 principal investigators of WMI: F. Deppe, K. Fedorov, R. Gross, A. Marx
 project partners: Forschungszentrum Jülich GmbH, Karlsruher Institut für Technologie, Friedrich-Alexander-Universität Erlangen-Nürnberg, Fraunhofer Gesellschaft zur Förderung der angewandten Forschung e.V, Infineon Technologies AG.
 project period: 02/2021 – 01/2025.

G. Free State of Bavaria

1. Munich Quantum Valley e.V. (MQV)
 program: Grundlagenorientierte Leuchtturmprojekte für Forschung, Entwicklung und Anwendungen im Bereich der Quantenwissenschaften und Quantentechnologien
 project part: Networked Quantum Systems (**NeQuS**)
 Principal Investigators at WMI: R. Gross, S. Filipp, K. Fedorov, A. Marx
 Jointly with research groups at the Technical University of Munich, the LMU Munich, and the Max Planck Institute of Quantum Optics.
 project period: 01/2023–12/2025.
2. Grundlagenorientierte Leuchtturmprojekte für Forschung, Entwicklung und Anwendungen im Bereich der Quantenwissenschaften und Quantentechnologien
 project part: Integrated Spin Systems for Quantum Sensors (**IQSense**)
 Principal Investigators at WMI: R. Gross, H. Hübl
 Jointly with research groups at the University of Würzburg and the Technical University of Munich.
 project period: 01/2023–12/2025.
3. Munich Quantum Valley e.V. (MQV)
 project part: Quantum Technology Park and Entrepreneurship (**QTPE**)
 Principal Investigators at WMI: Ch. Trummer (coordination), S. Filipp, R. Gross, K. Fedorov, A. Marx, H. Hübl.
 Jointly with research groups at the Technical University of Munich, the LMU Munich, the FAU Erlangen, the Max Planck Institute of Quantum Optics, and the Fraunhofer-Gesellschaft zur Förderung der angewandten Forschung e.V.
 project period: 10/2021–09/2026.
4. Munich Quantum Valley e.V. (MQV)
 project part: Superconducting Qubit Quantum Computing (**SQQC**)
 Principal Investigators at WMI: S. Filipp (coordination), K. Fedorov, R. Gross, A. Marx, H. Hübl
 Jointly with research groups at the Technical University of Munich, the LMU Munich, the FAU Erlangen, the Max Planck Institute of Quantum Optics, and the Fraunhofer-Gesellschaft zur Förderung der angewandten Forschung e.V.
 project period: 10/2021–09/2026.

H. Max Planck Society

1. Int. Max Planck Research School for *Quantum Science and Technology (IMPRS-QST)*,
 spokesperson: Prof. Dr. J. Ignacio Cirac,
 contributing researchers: R. Gross, A. Marx, F. Deppe, K. Fedorov, S. Filipp
 with several partners from the Max Planck Institute of Quantum Optics, the Ludwig-Maximilians-Universität Munich and the Technical University of Munich.
 project period: 03/2016–02/2028.

I. Swiss National Science Foundation

1. Project **AcQuaInt**: *An acoustic quantum interface for circuits and spins*,
 project number: 10000179
 project partner and coordinator: Y. Chu (ETH Zurich)
 principal investigators of WMI: P. Rabl
 project period: 03/2024 – 02/2028.

Conferences, Workshops, Public Engagement

Every year, the Walther-Meißner-Institute organizes/co-organizes conferences, workshops, symposia, seminars, and other events. It also participates in several public outreach events aiming at making science accessible to the public.

In previous years, we were reporting in more depth on events, outreach activities, press releases, highlight publications, and other events in our Annual Report. However, meanwhile these topics are well covered by our new web pages and social media accounts. Therefore, we are no longer covering these topics here in depth and refer the interested reader to the news section of our web pages: <https://www.wmi.badw.de/news> and <https://www.linkedin.com/company/49127991>.

In the following, we list some highlight outreach activities and public engagement of WMI in the year 2024:



01.03.2024: MQV Public Annual Report 2023 available. The Munich Quantum Valley has compiled a public report to provide an overview of its activities within 2023 to the public. As part of the Bavarian Hightech Agenda, MQV succeeded in establishing a vivid quantum ecosystem providing broad quantum education, excellent research, technology transfer, and innovative applications. *"We are proud of what we have achieved in the past year by joining forces in the Bavarian quantum ecosystem and I would like to thank all MQV members for their support in assembling the report"*, MQV Scientific Director

Rudolf Gross points out. The report can be downloaded [here](#).



12.04.2024: Symposium on Quantum Technologies was a big success. The [Symposium on Quantum Technologies](#) organized jointly by the Bavarian Academy of Sciences and Humanities (BAW) and the Munich Quantum Valley (MQV) was a big success. It took place in the premises of BAW in the Munich Residence with more than 300 participants. An additional audience of more than 300 followed the symposium in the livestream. **Rudolf Gross**, the Scientific and Managing Director of Munich Quantum Valley, led through the program. **Rainer Blatt**, Professor at the University of Innsbruck and former Scientific Director of MQV, gave an optimistic summary on the panel discussion: *"There is no physical system [particularly sophisticated technology] that tells me that it can't be done – but perhaps it will just take a little while."*

17.03. – 22.03.2024: DPG focus session on Nanomechanical Systems for Classical and Quantum Sensing. **Hans Huebl** organized the DPG focus session *Nanomechanical Systems for Classical and Quantum Sensing* together with **Hubert Krenner** (U. Münster) and **Eva Weig** (TUM). The focus session took place as part the DPG Spring Meeting of the Condensed Matter Section in Berlin.





26.04.2024: WMI hosts kick-off seminar of jDPG PhD-Kolleg. WMI hosts the kick-off seminar of the jDPG-Kolleg "Next Generation Computing". About 30 PhD students delved into questions spanning from the technical implementation of quantum computers, the availability and use cases of quantum algorithms, potential applications, to broader social implications. The efforts of the students are complemented by an advisory board from the scientific community (**Hans Huebl** - WMI, Jeanette Lorenz - FhG), industry (**Adrian Auter** - IQM) and organisations bridging the gap between industry and academia (**Andreas Böhm** - Bayern Innovativ). The opening talk by **Max Werninghaus** highlighted quantum processors and perfectly set the stage for the discussions during the weekend.



04.05.2024: "Cool" physics at BAdW's Day of open Doors. On Saturday, May 4th, the Bavarian Academy of Science opened its doors to the public. At the Residenz in Munich, over 5,500 visitors explored the various institutes that constitute the BAdW. On the forefront, the WMI showed interested adults and kids the fascinating physics that take place at ultra-low temperatures, ranging from experiments with liquid nitrogen and superconducting materials all the way up to modern quantum computing.



04.05.2024: Lunch Speaker Series of the BAdW. **Matthias Opel** (together with his colleagues from the Speaker Council) organized the "Lunch Speaker Series" in the library of the Bavarian Academy of Sciences and Humanities. The series is intended to bring together scientists from all research areas of the Academy every two months for a scientific exchange.

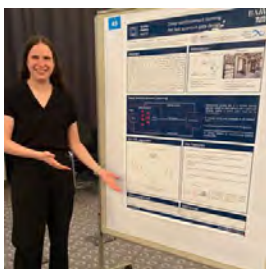

17.05.2024: Emily Wright received MCQST poster award. For her poster on 'Deep reinforcement learning for fast quantum gate design' **Emily Wright** won second place in the competition for the best poster at this year's MCQST Conference in Sonthofen. Congratulations!



18.06.2024: Deutsches Museum opens Exhibition on Light & Matter. The new permanent exhibition on "Light & Matter" has been jointly developed by the Cluster of Excellence MCQST and the Deutsches Museum. "The new exhibition makes quantum technology and quantum optical phenomena tangible for the broad public", **Rudolf Gross**, spokesperson of MCQST and member of the Fachbeirat of the exhibition says. "It is even better that the exhibition also allows us to present key MCQST results and an outlook on their future applications," he adds.



in Bologna, Italy, hosting 2000 researchers.

30.06. – 05.07.2024: International Conference of Magnetism (ICM2024). Hans Huebl organized the session at the International Conference of Magnetism (ICM2024) entitled *Frontiers in Magnonics* together with **Andrii Chumak** (U. Vienna). The ICM is the largest conference of the magnetism community worldwide and took place



program was complemented by an informal get-together in the evening of September 17, and lab tours on September 20 in the afternoon.

18.09. – 20.09.2024: International workshop on Rare-earth Ions for Quantum Information. The workshop was taking place in Munich from 17 to 20 September 2024, hosted by the Bavarian Academy of Sciences and Humanities in its premises at the Munich Residence. The organizing team includes **Nadezhda Kukharchyk** of WMI/BAdW and **Andreas Reiserer** of NAT/TUM. The scientific

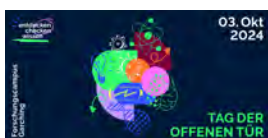

experiments with liquid nitrogen and superconducting materials all the way up to modern quantum computing were shown parallel to the talks on quantum computing.

3.10.2024: Nationwide "Doors open with the Mouse" campaign day. WMI also took part in the nationwide "Doors open with the Mouse" campaign day as part of the open house programs offered by Technical University of Munich (TUM). The fascinating physics experiments that take place at ultra-low temperatures, ranging from



superconducting qubits as key components for future quantum computers.

17.10.2024: WMI, TUM & HLL sign cooperation agreement The Max Planck Semiconductor Laboratory (HLL), the Technical University of Munich (TUM), and the Walther Meißner Institute (WMI) of the Bavarian Academy of Sciences (BAdW) have agreed on a groundbreaking collaboration for the joint development of superconducting quantum bits, or qubits, and quantum processors based on them. This partnership, established within the Munich Quantum Valley (MQV), marks a significant step in the research and advancement of quantum technologies. The collaboration aims to develop



showed the levitation of a high- T_c ($\text{YBa}_2\text{Cu}_3\text{O}_{7-\delta}$) superconductor above a permanent magnet by demonstrating the superconducting WMI racetrack.

26.10.2024: WMI welcomed a group of curious high school students from the Abingdon Senior School, Abingdon/Oxford, UK **Matthias Opel** hosted 28 pupil (between 14 and 16 years old) and 4 physics teachers during their stay in Munich on 19th October 2024 in the WMI. They performed experiments at low temperatures with liquid nitrogen. He explained the Meißner-Ochsenfeld effect and



27.10. – 31.10.2024: 820. WEH Seminar on Hybrid Angular Momentum Transport and Dynamics - Halloween edition. Together with colleagues from the University, researchers from WMI organized a seminar dedicated to the recent progress in angular momentum transport and dynamic interactions in solid state systems. We had many young scientists attending the conference and enjoying the evening special lecture on horrors in research.



03.12.2024: **Matthias Althammer receives ERC CoG.** The European Research Council (ERC) has awarded its Consolidator Grants (CoG) to 328 outstanding scientists in 25 EU Member States with a total budget of 678 million euros. **Matthias Althammer** was awarded one of these prestigious grants, allowing him to implement his ambitious research project, on antiferromagnetic magnonics as a platform for energy-efficient information processing. *"I am very happy that Matthias was successful in this highly competitive funding scheme with a total success rate of only 14.2%"*, **Rudolf Gross**, scientific director at WMI, says.



03.12.2024: **Hans Hübl appointed Adjunct Professor at TUM.** The Technical University of Munich (TUM) has appointed **Dr. habil. Hans Hübl** as an Adjunct Professor in recognition of his excellent contributions to both research and teaching. Hans Hübl is a research group leader at the WMI since 2009 and a lecturer at the TUM since 2014. As a member of the excellence cluster MCQST and the Munich Quantum Valley, he makes key contributions to the successful research and teaching program in quantum science and technology. *"Congratulations to Hans! I am very happy that again a member of my group was honored with the award of an adjunct professorship"*, **Rudolf Gross**, scientific director at WMI says.

Cooperations

The Walther-Meißner-Institute is involved in many collaborations also without any direct project funding. In the following, we list the most relevant collaboration partners:

National

- **Heinz Maier-Leibnitz Zentrum, Technische Universität München (TUM), Garching, Germany:** J. M. Gomez, R. Dutta, A. Maity
- **School of Engineering and Design, Technische Universität München (TUM), Garching, Germany:** S. Berensmeier, M. Tornow
- **School of Natural Sciences, Technische Universität München (TUM), Garching, Germany:** P. Müller-Buschbaum, Ch. Everett, L. Van Damme, S. Glaser, J. Knolle, B. Kraus, Ch. Pfleiderer, C. Back, M. Poot, A. Reiserer
- **School of Computation, Information and Technology, Technische Universität München (TUM), Garching, Germany:** M. Becherer, V. Ahrens, J. Greil, M. Geiger, C. Mendl, R. Wille, E. Weig, W. Utschick
- **Technical University of Munich, Walter Schottky Institute, Munich, Germany:** J. Finley, M. Brandt, A. Holleitner, K. Müller
- **LMU, Faculty of Physics, Munich, Germany:** F. Grusdt
- **University of Augsburg, Augsburg, Germany:** A. Aqeel, I. Kecmarki, M. Albrecht
- **Friedrich-Alexander-Universität, Erlangen, Germany:** M. Hartmann, C. Eichler
- **Fraunhofer IIS, Erlangen, Germany:** H. Adel
- **High Magnetic Field Laboratory, Helmholtz-Zentrum Dresden-Rossendorf, Dresden, Germany:** J. Wosnitza, T. Helm
- **Helmholtz Zentrum Dresden-Rossendorf, Institut für Ionenphysik, Dresden-Rossendorf, Germany:** H. Schultheiss, K. Schultheiss
- **RPTU Kaiserslautern-Landau, Kaiserslautern, Germany:** A. Kamra, M. Weiler
- **Fakultät für Physik, Universität Konstanz, Germany:** W. Belzig, U. Nowak, M. Müller, M. Lammel, R. Schlitz, S.T.B. Gönnenwein
- **PTB Braunschweig, Braunschweig, Germany:** L. Grünhaupt, O. Kieler
- **FUB, Berlin, Germany:** M. Krauss, C. Koch
- **Karlsruher Institut für Technologie (KIT), Karlsruhe, Germany:** I. Pop, A. Metelmann
- **Goethe-Universität Frankfurt, Frankfurt-am-Main, Germany:** J. Müller, M. Lang
- **Universität Stuttgart, Stuttgart, Germany:** M. Dressel, K. Kanoda, R. Kolesov
- **Max-Planck-Institut für Festkörperforschung, Stuttgart, Germany:** K. Kanoda, T. Sekine
- **Faculty of Physics, Universität Duisburg-Essen, Duisburg, Germany:** K. Ollefs, H. Wende
- **Center for Spinelectronic Materials and Devices, Department of Physics, Bielefeld University, Bielefeld, Germany:** T. Kuschel, M. Meinert
- **RWTH Aachen, Aachen, Germany:** S. Viola Kusminsky, M. Müller
- **Forschungszentrum Jülich, Jülich, Germany:** P. Bushev, F.K. Wilhelm-Mauch, D. Di-Vincenzo, G. Bishop, F. Wilhelm, R. Riccardo

European

- **Technische Universität Wien, Wien, Austria:** A. Pustogow, S. Rotter, T. Pohl

- **University of Vienna, Vienna, Austria & Austrian Academy of Sciences:** M. Aspelmeyer, M. Trupke
- **Institute for Science and Technology Austria, Klosterneuburg, Austria:** J. Fink
- **University of Innsbruck, Innsbruck, Austria:** G. Kirchmair
- **Parity QC, Innsbruck, Austria:** P. Aumann, C. Ertler
- **Department of Chemical Physics and Optics, Charles University, Prague, Czech Republic:** Lukáš Nádvořník
- **Institute of Physics of the Czech academy of sciences, Prague, Czech Republic:** T. Jungwirth, H. Reichlova, D. Kriegner, M. Leiviskä
- **Aalto University, Espoo, Finland:** R. Di Candia
- **VTI, Espoo, Finland:** V. Vesterinen, A. Kemppinen
- **European Synchrotron Radiation Facility (ESRF), Grenoble, France:** F. Wilhelm, A. Rogalev
- **Laboratoire National des Champs Magnétiques Intenses, LNCMI-EMFL, Grenoble, France:** I. Sheikin
- **Institut Laue-Langevin (ILL), Grenoble, France:** M. Enderle, T. Ziman
- **Centre national de la recherche scientifique (CNRS), Grenoble, France:** Y. Joly
- **Université de Bourgogne, Bourgogne, France:** D. Sugny
- **Universita di Trento, Trento, Italy:** J. Carusotto
- **University of Palermo, Palermo, Italy:** F. Ciccarello
- **Institute of Materials Science of Barcelona (ICMAB-CSIC), Barcelona, Spain:** C. Onur, J. Gückelhorn
- **Universidad del País Vasco and Ikerbasque Foundation, Bilbao, Spain:** M. Sanz
- **Universidad Autonoma de Madrid, Madrid, Spain:** S. Velez
- **Instituto de Física Fundamental CSIC, Madrid, Spain:** J.J. Garcia-Ripoll, A. Gonzales-Tudela
- **CIC nanoGUNE, San Sebastian, Spain:** F. Casanova
- **European Spallation Source (EES), Lund, Sweden:** D. Mannix
- **École Polytechnique Fédérale de Lausanne – (EPFL), Lausanne, Switzerland:** H Rønnow
- **ETH-Zurich, Zurich, Switzerland:** A. Wallraff, Y. Chu
- **University of St Andrews, St. Andrews, United Kingdom:** N. Korolkova
- **University of Kent, Kent, United Kingdom:** B. Tomasello

International

- **Beihang University, Beijing, China:** H. Yu
- **Materials Science Research Centre, IIT Madras, Chennai, India:** M.S. Ramachandra Rao, Kaushalya Kumari
- **Weizmann Institute of Science, Rehovot, Isreal:** A. Poddubny
- **WPI Advanced Institute for Materials Research, Tohoku University, Sendai, Japan:** G.E.W. Bauer
- **RIKEN Center for Quantum Computing, Wako, Saitama, Japan:** Y. Nakamura
- **University of Kyoto, Kyoto, Japan:** M. Shiraishi
- **Department of Materials Science and Engineering, Madison, USA:** P.G. Evans
- **Harvard University, Cambridge, USA:** M. Loncar, M. Lukin

Industrial

- **German Aerospace Center, Microwaves and Radar Institute, Oberpfaffenhofen, Germany:** M. Peichl
- **German Space Agency (DLR), Germany:** Santana Lujan, Nikolas Pomplun
- **Rohde & Schwarz, Munich, Germany:** G. Hechtfisher
- **BMW, Munich, Germany:** C. Riofrío
- **Infineon, Munich, Germany:** S. Lubber, J. Banker
- **Fraunhofer Research Institution for Microsystems and Solid State Technologies EMFT, Munich, Germany:** Ch. Kutter, K. Bauer, R. Pereira
- **Kiutra, Munich, Germany:** F. Rucker, A. Regnat

Research Stays

Also in 2024, extended research stays of members of the Walther-Meißner-Institute at other national or international laboratories have been significantly reduced reminiscent of the Covid-19 pandemic.

1. **Matthias Opel**
Spintec, Grenoble, France
22.04. - 26.04.2024
2. **Shamil Erkenov and Mark Kartsovnik**
Dresden High Magnetic Field Laboratory (HLD), Rossendorf, Germany
12.01. - 27.01.2024 and
27.05 - 01.06.2024
Laboratoire National des Champs Magnétiques Intenses, LNCMI-EMFL, Grenoble, France
30.09. - 15.10.2024
3. **Stephan Geprägs**
European X-Ray Free-Electron Laser (XFEL) Facility, Schenefeld, Deutschland
26.04. - 29.04.2024
European Synchrotron Radiation Facility (ESRF), Grenoble, France
05.11. - 11.11.2024

Conference Talks and Seminar Lectures

Joan Agusti

1. **Programmable multiqubit entanglement distribution**
Seminar talk, MCQST Colloquium, Garching, Germany
06.02.2024
2. **Programmable multiqubit entanglement distribution**
Seminar talk, MPQ Theory Seminar, Garching, Germany
15.03.2024
3. **Multiqubit entanglement distribution using correlated photons**
Seminar talk, Quantum Science and Technology Seminar, Naples, Italy
15.05.2024
4. **Multiqubit entanglement distribution**
Seminar talk, Qunipa Seminar, Palermo, Italy
16.05.2024

Matthias Althammer

1. **Chiral phonons and phononic birefringence in ferromagnetic metal-bulk acoustic resonator hybrids**
Contributed talk, American Physical Society March Meeting, Minneapolis (Virtual), USA
03.03-08.03.2024
2. **Pure spin currents in thin film heterostructures**
Invited talk, University of Vienna, Vienna, Austria
26.04.2024
3. **All-electrical angular momentum transport experiments in antiferromagnetic insulators and isolated ferromagnetic metals**
Invited talk, International Conference on Magnetism and Superconductivity, Fethiye-Oludeniz, Turkey
27.04-04.05.2024
4. **All-electrical angular momentum transport experiments in antiferromagnetic insulators and isolated ferromagnetic metals**
Invited talk, SPICE workshop: Hybrid Correlated States and Dynamics in Quantum Materials, Ingelheim, Germany
14.05-16.05.2024
5. **Chiral phonons and phononic birefringence in ferromagnetic metal-bulk acoustic resonator hybrids**
Contributed talk, Spin Mechanics 8, Troutdale, USA
04.08.-09.08.2024
6. **All-electrical angular momentum transport experiments in antiferromagnetic insulators and isolated ferromagnetic metals**
Invited talk, SPIE Spintronics XVII, San Diego, USA
18.08.-23.08.2024
7. **All-electrical angular momentum transport experiments between isolated ferromagnetic metals**
Seminar talk, University of Groningen, Groningen, Netherlands
05.09.2024
8. **All-electrical angular momentum transport in antiferromagnetic insulators**
Invited talk, Lanna Meeting of the Institute of Physics, Czech Academy of Sciences, Prague, Czech Republic
18.11.-19.11.2024

Daniil Bazulin

1. **Phase-flux symmetries in superconducting three-wave mixing travelling wave parametric amplifiers**

Contributed talk, Spring Meeting of the German Physical Society, Berlin, Germany
17.03.-22.03.2024

Niklas Bruckmoser

1. **Improving Fabrication Methods for High Coherence Superconducting Qubits**
Contributed Talk, DPG Spring Meeting Berlin, Berlin, Germany
18.03. - 22.03.2024

Shamil Erkenov

1. **Effect of anion substitution on the Mott insulating instability in the organic conductors κ -(BEDT-TTF)₂X studied by magnetic quantum oscillations**
Contributed talk, Spring Meeting of the German Physical Society, Berlin, Germany
17.03 - 22.03.2024

Kirill Fedorov

1. **Microwave quantum networks**
Invited talk, Spring Meeting of the German Physical Society, Berlin, Germany
17.03.-22.03.2024
2. **Microwave quantum networks**
Invited talk, University of Münster, Münster, Germany
21.10.2024

Julius Feigl

1. **Frequency Tuning of Superconducting Qubits by Laser Annealing of Josephson Junctions**
Contributed Talk, DPG Spring Meeting Berlin, Berlin, Germany
18.03 - 22.03.2024

Florian Fesquet

1. **Microwave quantum tokens with time multiplexing**
Contributed talk, Spring Meeting of the German Physical Society, Berlin, Germany
17.03.-22.03.2024

Stefan Filipp

1. **Versatile quantum operations between superconducting qubits based on parametric interactions**
Seminar Talk, Royal Institute of Technology (KTH), Stockholm, Sweden
30.01.2024
2. **Fabrication and operation of superconducting quantum circuits for QIP**
Invited talk, Workshop at the Max Planck Institute Microstructure Physics, Halle, Germany
29.11.2024
3. **Quantencomputing - wie sieht der Rechner der Zukunft aus?**
Invited talk, Lunch talk of the Bavarian Academy of Sciences, Munich, Germany
28.11.2024
4. **Munich Quantum Valley Quantum Computing Demonstrators - Superconducting Qubits**
Invited talk, Quantumcomputing Demonstrators Mid-Term Meeting, Berlin, Germany
22.10.2024
5. **Quantum information processing with superconducting circuits**
Invited talk, Opening symposium of the MPG Halbleiterlabor, Munich, Germany
8.10.2024
6. **Warum kann Quantencomputing unlösbare Probleme lösen?**
Invited talk, Open House at the Walther-Meissner-Institute, Munich, Germany
3.10.2024
7. **Advances in controlling superconducting qubits for quantum computing**
Invited talk, Munich-Waterloo Joint Workshop, Waterloo, Canada
30.09.2024

8. **Controlling superconducting qubits for quantum computing**
Invited talk, Italian Quantum Information Science Conference, Pizzo Calabro, Italy
16.09.2024
9. **Current MQV hardware development with superconducting qubits**
Invited talk, Munich Quantum Valley Supplier Workshop, Munich, Germany
20.06.2024
10. **Quantencomputing - wie sieht der Rechner der Zukunft aus?**
Invited talk, Schelling Forum, Würzburg, Germany
11.06.2024
11. **Tunable coupler mediated interactions between two and more superconducting qubits**
Invited talk, Wallenberg Center for Quantum Technology (WACQT) Review Meeting, Gothenborg, Sweden
16.05.2024
12. **Warum kann Quantencomputing unlösbare Probleme lösen?**
Invited talk, Open House at the Bavarian Academy of Sciences, Munich, Germany
04.05.2024

Simon Gandorfer

1. **Investigation of hybrid entanglement in the microwave regime**
Contributed talk, Spring Meeting of the German Physical Society, Berlin, Germany
17.03.-22.03.2024

Louis Garbe

1. **Critical sensing with finite-size bosonic systems**
Invited talk, QUMINOS workshop, Les Diablerets, Switzerland
11.-16.02.2024
2. **No boson is an island**
Seminar talk, MPQ Theory Seminar, Garching, Germany
04.09.2024
3. **No boson is an island**
Seminar talk, Laboratoire Ondes et Matière d'Aquitaine, Bordeaux, France
29.10.2024

Stephan Geprägs

1. **Non-reciprocal Magnon Hanle Effect in Antiferromagnetic α -Fe₂O₃**
International Workshop on Oxide Electronics, Darmstadt, Germany
29.09. - 02.10.2024

Niklas Glaser

1. **Closed-loop Optimization for high-fidelity Controlled-Z Gates in Superconducting Qubits**
Contributed talk, 2024 APS March Meeting, Minneapolis, USA
04.03. - 08.03.2024
2. **Closed-loop Optimization for High-fidelity Controlled-Z Gates in Superconducting Qubits**
Invited talk, Quantum Technology User Meeting, Zürich, Switzerland
18.01.2024

Matthias Grammer

1. **Electrically induced angular momentum flow between separated ferromagnets**
Contributed talk, Spring Meeting of the German Physical Society, Berlin, Germany
17.03.-22.03.2024

Maria-Teresa Handschuh

1. **Frequency targeting and geometric effects in fabrication of superconducting tunable resonators**
Contributed talk, Spring Meeting of the German Physical Society, Berlin, Germany
17.03.-22.03.2024

Gerhard Huber

1. **Parametric coupler architecture for on-demand reset, readout and leakage recovery of superconducting qubits**
Contributed Talk, DPG Spring Meeting Berlin, Berlin, Germany
18.03 - 22.03.2024
2. **Designing Superconducting Qubits for Quantum Computing**
Invited talk, CADFEM Conference, Darmstadt, Germany
10.04 - 11.04.2024

Hans Huebl

1. **Hybrid Quantum Systems Probing Solid-State Excitations**
Invited talk, SPICE Workshop : "Hybrid Correlated States and Dynamics in Quantum Materials, Ingelheim, Germany
14. 05. - 16. 05. 2024
2. **Quantum hybrids: connecting spin excitations to resonators**
Invited talk, SPICE online Seminar Series
02. 10. 2024
3. **Connecting Spins and Phonons**
Invited talk, WEH Seminar 820 : "Hybrid Angular Momentum Transport and Dynamics", Bad Honnef, Germany
27. 10. - 31. 10. 2024
4. **Optomechanics with Superconducting Quantum Circuits**
Invited talk, Metelmann Group Retreat, Strassbourg, France
13. 11. 2024

Mark Kartsovnik

1. **Physical and chemical pressure effects in κ -(BEDT-TTF)₂X near the Mott transition explored by magnetic quantum oscillations**
Invited talk, Seminar at the 1. Physikalisches Institut, Universität Stuttgart, Stuttgart, Germany
20.02.2024

Kevin Kiener

1. **Multiplexed Single Flux Quantum Qubit Readout with a Josephson Photomultiplier**
Contributed talk, Applied Superconductivity Conference, Salt Lake City, USA
01.09. - 06.09.2024

Leon Koch

1. **Characterization of fabrication methods to reach high coherence superconducting quantum circuits**
Contributed talk, 2024 APS March Meeting, Minneapolis, USA
04.03. - 08.03.2024

Nadezhda Kukharchyk

1. **Addressing the rare-earth spin ensembles by propagating microwaves in broadband regime**
Invited talk, MCQST Conference 2024, Sonthofen, Germany
17.03.2024

Benjamin Lienhard

1. **Noise-Resilient Control of Quantum Information Processors**
Invited talk, BMBF Quantum Futur Status Meeting, Hannover, Germany
04.12.2024

Jacquelin Luneau

1. **Quantum chaos in a quantum optical simulation of a topological insulator**
Contributed talk, DPG Spring Meeting, Dresden, Germany
18.03.2024

2. **Quantum optical simulation of a Chern insulator**
Seminar talk, QMQI Blackboard seminar, Garching, Germany
13.06.2024
3. **Multi-photon transitions in superconducting circuits**
Contributed talk, MQV-HAT workshop, Erlangen, Germany
17.06.2024
4. **Topological frequency conversion**
Contributed talk, Benasque workshop Quantum Science: Implementation, Benasque, Spain
28.06.2024
5. **Applied Quantum Theory**
Contributed talk, MQV-HAT Site Visit, Erlangen, Germany
12.09.2024
6. **Quantum simulation of a topological insulator at high electric field**
Seminar talk, LOMA Seminar, University of Bordeaux, France
12.11.2024

Adrian Misselwitz

1. **Waveguide QED with photon-photon interaction**
Seminar talk, Joint Seminar MPQ-WMI, Garching, Germany
22.11.2024

Patricia Oehrl

1. **Efficiency of pulsed electron spin resonance protocols for quantum state storage with phosphorus donors in silicon**
Contributed talk, Spring Meeting of the German Physical Society, Berlin, Germany
17.03.-22.03.2024
2. **Pulsed electron spin resonance protocols for quantum memory applications**
Contributed talk, Silicon Quantum Electronics Workshop, Davos, Switzerland
04.09. – 06.09.2024

Matthias Opel

1. **Magnon Spin Transport in Antiferromagnetic Insulators**
Invited seminar lecture, Spintec, Grenoble, France
26.04.2024
2. **Nonreciprocal Magnon Hanle Effect in Antiferromagnetic α -Fe₂O₃**
Contributed talk, International Conference on Magnetism (ICM), Bologna, Italy
05.07.2024
3. **Magnetic anisotropy and magnon spin transport in antiferromagnetic α -Fe₂O₃ thin films**
Contributed talk, International Colloquium on Magnetic Films and Surfaces (ICMFS), Perugia, Italy
11.07.2024
4. **Spin Hall Magnetoresistance in Antiferromagnetic Insulators**
Invited seminar lecture, Czech Academy of Sciences, Prague, Czechia
19.11.2024

Frederik Pfeiffer

1. **Simultaneous Purcell and shot-noise protection in a flux-noise resistant multi-mode superconducting qubit**
Contributed talk, 2024 APS March Meeting, Minneapolis, USA
04.03. - 08.03.2024
2. **Efficient decoupling of a non-linear qubit mode from its environment**
Contributed talk, QUANTUMatter 2024, San Sebastian, Spain
06.05. - 10.05.2024

Peter Rabl

1. **Ultrastrong coupling physics in cavity and circuit QED**
Seminar talk, University of Palermo, Italy
12.03.2024
2. **Novel approaches in quantum communication**
Contributed talk, NeQuS Meeting, Garching, Germany,
04.04.2024
3. **High-fidelity quantum information processing with spins and phonons**
Invited talk, MURI Meeting, Arlington, USA
15.05.2024
4. **Quantum information processing with spins and phonons**
Invited talk, CalBay Summer School, Garching, Germany
11.06.2024
5. **Light-matter interactions in a photonic quantum fluid**
Invited talk, Quantum Optics meets Tensor Networks, Bari, Italy
05.09.2024
6. **Faszination Quantencomputer**
Seminar talk, Campus Garching Open Day, Garching, Germany,
03.10.2024
7. **Applied Quantum Theory**
Contributed talk, MQV Review Meeting, Eichstätt, Germany,
09.10.2024
8. **Autonomous entanglement distribution in (hybrid) quantum networks**
Seminar talk, University of Vienna, Austria,
02.12.2024

Joao Romeiro

1. **Parity-Dependent State Transfer and Many-Qubit Entanglement Generation on a Superconducting Qubit Chain**
Contributed talk, 2024 APS March Meeting, Minneapolis, USA
04.03. - 08.03.2024

Federico Roy

1. **Parity-Dependent State Transfer and Entanglement Generation on a Superconducting Qubit Chain**
Seminar Talk, GeQCoS 6th Progress Meeting, Aachen, Germany
09.04. - 10.04.2024
2. **Parity-Dependent State Transfer for Direct Entanglement Generation**
Contributed Talk, CMD₃₁ Braga MC13, Braga, Portugal
01.09. - 06.09.2024

Korbinian Rubenbauer

1. **Optimization of Flux-Tunable Microwave Resonators for Strong Single-Photon Optomechanics in Nano-Electromechanical Systems**
Contributed talk, Spring Meeting of the German Physical Society, Berlin, Germany
17.03.-22.03.2024

Monika Scheufele

1. **Impact of growth conditions on magnetic anisotropy and magnon Hanle effect in α -Fe₂O₃**
Contributed talk, Spring Meeting of the German Physical Society, Berlin, Germany
17.03.-22.03.2024

Christian Schneider

1. **Quantum Computing Hardware Introduction**
Seminar talk, MCQST Summer Bachelor Program, Munich, Germany
08.08.2024

2. Protected Qubit Control with Sub-Harmonic Parametric Driving

Invited talk, MQV Colloquium, Online

08.08.2024

Ana Strinic**1. Characterization of hyperfine transitions of rare-earth spin ensembles via broadband ESR spectroscopy at mK temperatures**

Contributed talk, Spring Meeting of the German Physical Society, Berlin, Germany

17.03.-22.03.2024

2. Characterization of hyperfine transitions of rare earth spin ensembles via broadband ESR spectroscopy

Contributed talk, Rare-earth Ions for Quantum Information, Munich, Germany

17.09.-20.09.2024

Florian Wallner**1. High Fidelity Readout of Fluxonium Qubits**

Contributed Talk, DPG Spring Meeting Berlin, Berlin, Germany

18.03. - 22.03.2024

Johannes Weber**1. Magnon-phonon coupling in $\text{Co}_{25}\text{Fe}_{75}$ thin film/crystalline substrate heterostructures**

Contributed talk, Spring Meeting of the German Physical Society, Berlin, Germany

17.03.-22.03.2024

Max Werninghaus**1. Quantum Computing with Noisy Processors**

Invited talk, MQV K7 meeting, Munich, Germany

05.10.2024

2. Quantum Computing Efforts at the Walther-Meißner-Institute - Scaling, Novel Qubits and Fundamental Research

Invited talk, Lorentz Center Workshop "Bridging the Gap Between Classical and Quantum Simulation", Leyden, Netherlands

05.05. - 08.05.2024

3. Skalierbare Kontrolle von Supraleitenden Quantenprozessoren

Invited talk, QNC Summit 2024, Berlin, Germany

24.04.2024

Wun Kwan Yam**1. Microwave quantum teleportation in a thermal environment**

Contributed talk, Spring Meeting of the German Physical Society, Berlin, Germany

17.03.-22.03.2024

Przemyslaw Zielinski**1. Ultrafast quantum state transfer and the speed limit of quantum communication**

Contributed talk, DFG Meeting, Dresden, Germany

18.03.2024

2. Ultrafast quantum state transfer and the speed limit of quantum communication

Seminar talk, Joint Seminar MPQ-WMI, Garching, Germany

25.10.2024

Membership in Advisory Boards, Committees, etc.

1. **Frank Deppe** is a member and principal investigator of the Cluster of Excellence *Munich Center for Quantum Science and Technology (MCQST)*.
2. **Stefan Filipp** is member of the *Supervisory Board of the Max Planck Semiconductor Laboratory*.
3. **Stefan Filipp** is coordinator of the *Munich Quantum Valley (MQV) consortium K1 - Superconducting Qubit Quantum Computing*.
4. **Stefan Filipp** is coordinator of the *Munich Quantum Valley Quantumcomputer Demonstrators – Superconducting Qubits (MUNIQC-SC)* project funded by the Federal Ministry of Education and Research (BMBF).
5. **Stefan Filipp** is a member of the scientific advisory board of the EU FET Open project *AVAQUS - Annealing based Variational Quantum Processors*.
6. **Stefan Filipp** is a member of the executive board of the *Wallenberg Center for Quantum Technology*.
7. **Stefan Filipp** is editorial board member of the IOP multidisciplinary journal *Materials for Quantum Technology*.
8. **Stefan Filipp** is a member and principal investigator of the Cluster of Excellence *Munich Center for Quantum Science and Technology (MCQST)*.
9. **Stefan Filipp** is an adjoint Member of the Special Research Fund (SFB) *BeyondC* funded by the Austrian Science Fund (FWF).
10. **Stefan Filipp** is member of the *Munich Quantum Center (MQC)*.
11. **Rudolf Gross** is spokesperson (together with Immanuel Bloch and Ignacio Cirac) of the Cluster of Excellence *Munich Center for Quantum Science and Technology (MCQST)* and coordinator of the Research Unit C on *Quantum Computing*.
12. **Rudolf Gross** is initiator and Principal Investigator of *Munich Quantum Valley (MQV)*.
13. **Rudolf Gross** is Scientific Director of *Munich Quantum Valley (MQV)* (until 06/2024) and Managing Director of the MQV Association (until 12/2024).
14. **Rudolf Gross** is a member of the *Deutsche Akademie der Technikwissenschaften e.V. (acatech)*.
15. **Rudolf Gross** is a member of the *Forum Technologie* of the Bavarian Academy of Sciences and Humanities.
16. **Rudolf Gross** is Co-organizer of the annual *Munich Conference on Quantum Science & Technology*.
17. **Rudolf Gross** was a member of the Advisory Board of the permanent exhibition on *Matter and Light* of the German Science Museum (2019-2024).
18. **Rudolf Gross** is a member of the *Committee for the allocation of Alexander von Humboldt Foundation Research Awards*.
19. **Rudolf Gross** was a member of the *Appointment and Tenure Board* of the Technical University of Munich (until 12/2024).

20. **Rudolf Gross** is a member of the *Munich Quantum Center (MQC)*.
21. **Rudolf Gross** is a member of the *Scientific Advisory Board of the Bavarian Research Institute of Experimental Geochemistry and Geophysics (BGI), Bayreuth, Germany*.
22. **Rudolf Gross** is a member of the *Scientific Advisory Board of the Institut de Ciència de Materials de Barcelona, Spain*.
23. **Hans Huebl** is a member and principal investigator of the Cluster of Excellence *Munich Center for Quantum Science and Technology (MCQST)*.
24. **Hans Huebl** is a member and principal investigator of the Collaborative Research Center *360 Constrained Quantum Matter (ConQuMat)*.
25. **Hans Huebl** is member of the *Munich Quantum Valley (MQV) consortium K1 - Superconducting Qubit Quantum Computing*, the MQV Lighthouse Projects *Networked Quantum Systems (NeQuS)* and *Integrated Spin Systems for Quantum Sensors (IQ-Sense)*
26. **Hans Huebl** is a member of the *Munich Quantum Center (MQC)*
27. **Mark Kartsovnik** is a member of the Selection Committee of EMFL (European Magnetic Field Laboratory).
28. **Mark Kartsovnik** is a member of the International Advisory Committee of the International Symposium on Crystalline Organic Metals Superconductors and Ferromagnets (ISCOM).
29. **Nadezhda Kukharchyk** is Coordinator of the BMBF Project *Mikrowellen-Quanten-Token in Elektronen- und Kernspin-Ensembles (QuaMToMe)* participating in the "Grand Challenge der Quantenkommunikation".
30. **Nadezhda Kukharchyk** is a member of the Cluster of Excellence *Munich Center for Quantum Science and Technology (MCQST)*.
31. **Nadezhda Kukharchyk** is a member of the *International Max-Planck Research School (IMPRS) Steering Committee* .
32. **Nadezhda Kukharchyk** is a member of the "*Quantum Talent Symposium Munich*" *Selection Committee*.
33. **Matthias Opel** is one of the four elected members of the *Speaker Council* for the scientists of the Bavarian Academy of Sciences and Humanities.
34. **Peter Rabl** is a member of the *Munich Quantum Valley (MQV) consortium K8 - Hardware Adapted Theory*.
35. **Peter Rabl** is principal investigator of the *Munich Quantum Valley (MQV) Lighthouse Project - Networked Quantum Systems (NeQuS)*
36. **Peter Rabl** is a member of the Cluster of Excellence *Munich Center for Quantum Science and Technology (MCQST)*.
37. **Peter Rabl** is a member of the *Munich Quantum Center (MQC)*.
38. **Peter Rabl** is an adjoint Member of the Special Research Fund (SFB) *BeyondC* funded by the Austrian Science Fund (FWF).

Teaching



Lectures, Courses and other Teaching Activities

Several members of the Walther-Meißner-Institute give lectures and seminars at the Technical University of Munich.

- WS 2023/2024
- WMI Seminar on Current Topics of Low Temperature Solid State Physics (M. Althammer, F. Deppe, K. Fedorov, S. Filipp, R. Gross, S. Geprägs, H. Huebl, N. Kukharchyk, A. Marx, M. Opel, P. Rabl)
 - Seminar: Novel Topics in Magnetism: quantum hybrid systems, spin dynamics, and angular momentum transport (M. Althammer, H. Huebl, N. Kukharchyk, M. Opel, S. Geprägs)
 - Seminar: Advances in Solid-State Physics (R. Gross with M. Althammer, S. Geprägs, H. Huebl, M. Kartsovnik, A. Marx, N. Kukharchyk, M. Opel)
 - Seminar: Quantum Science and Technology in Solids: spins, microwaves, and optomechanics (M. Althammer, M. S. Brandt, H. Huebl, S. Geprägs)
 - Seminar: Journal Club on Quantum Systems (S. Filipp, C. Schneider)
 - Seminar: Superconducting Quantum Circuits (S. Filipp, R. Gross, M. Werninghaus)
 - Lecture: Superconductivity and Low Temperature Physics 1 (R. Gross)
 - Problem Session: Superconductivity and Low Temperature Physics 1 (R. Gross with N.N.)
 - Lecture: QST Experiment: Quantum Hardware (S. Filipp)
 - Problem Session: QST Experiment: Quantum Hardware (S. Filipp with G. Krylov)
 - Lecture: Applied Superconductivity 1: from Josephson Effects to RSFQ Logic (K. Fedorov)
 - Problem Session: Applied Superconductivity 1: from Josephson Effects to RSFQ Logic (K. Fedorov)
 - Lecture: Quantum sensing (H. Hübl with M. Brandt, D. Bucher)
 - Lecture: Magnetism (M. Althammer)
 - Problem Session: Magnetism (M. Althammer with K. Rubenbauer)
 - Colloquium on Solid-State Physics (R. Gross with H. Huebl, M. Opel)
 - Lecture: Theory of Open Quantum Systems (P. Rabl)
 - Problem Session: Exercise to Theory of Open Quantum Systems (P. Rabl)
 - Seminar: Cavity-, Waveguide- and Circuit QED (P. Rabl)
 - Seminar: WMI Theory Seminar (P. Rabl)
 - FOPRA Experiment 104: The Josephson Parametric Amplifier (JPA) (R. Gross, with K. Honasoge, W. K. Yam)
 - FOPRA Experiment 16: Josephson Effects in Superconductors (R. Gross, with K. Honasoge, W. K. Yam)
 - FOPRA Experiment 108: Qubit Control and Characterization for Superconducting Quantum Processors (L. Koch, I. Tsitsilin)
- SS 2024
- WMI Seminar on Current Topics of Low Temperature Physics (M. Althammer, F. Deppe, K. Fedorov, S. Filipp, R. Gross, S. Geprägs, H. Huebl, N. Kukharchyk, A. Marx, M. Opel, P. Rabl)
 - Seminar: Novel Topics in Magnetism: quantum hybrid systems, spin dynamics, and angular momentum transport (M. Althammer, H. Huebl, N. Kukharchyk, M. Opel, S. Geprägs)
 - Seminar: Quantum Science and Technology in Solids: spins, microwaves, and optomechanics (M. S. Brandt, H. Huebl)
 - Seminar: Advances in Solid State Physics (R. Gross with M. Althammer, S. Geprägs, H. Huebl, M. Kartsovnik, A. Marx, N. Kukharchyk, M. Opel)

- Seminar: Superconducting Quantum Circuits (F. Deppe, S. Filipp, R. Gross, A. Marx, K. Fedorov)
- Seminar: Journal Club on Quantum Systems (S. Filipp)
- Lecture: Superconductivity and Low Temperature Physics 2 (R. Gross)
- Problem Session: Superconductivity and Low Temperature Physics 2 (R. Gross with K. Fedorov and S. Gandorfer)
- Lecture: Applied Superconductivity 2: from superconducting circuits to microwave quantum optics (K. Fedorov)
- Problem Session: Exercise to Applied Superconductivity 2: from superconducting circuits to microwave quantum optics (K. Fedorov)
- Lecture: Quantum Computing with Superconducting Qubits: architecture and algorithms (S. Filipp)
- Problem Session: Quantum Computing with Superconducting Qubits: architecture and algorithms (S. Filipp, M. Werninghaus)
- Lecture: Spintronics (M. Althammer)
- Problem Session: Spintronics (M. Althammer with K. Rubenbauer)
- Lecture: Theoretical Quantum Optics (P. Rabl)
- Problem Session: Theoretical Quantum Optics (P. Rabl)
- Colloquium on Solid-State Physics (R. Gross with H. Huebl, M. Opel)
- Seminar: Cavity-, Waveguide- and Circuit QED (P. Rabl)
- Seminar: Photonic Many-Body Systems (P. Rabl, L. Garbe)
- Seminar: Dissipative Quantum Systems (X. Zhang)
- Seminar: Circuit QED (P. Rabl, J. Luneau)
- Seminar: WMI Theory Seminar (P. Rabl)
- Quantum Entrepreneurship Laboratory (S. Filipp, R. Cercola, C. Mendl, F. Pollmann, R. Wille)
- FOPRA Experiment 104: The Josephson Parametric Amplifier (JPA) (R. Gross, with K. Honasoge, W. K. Yam)
- FOPRA Experiment 16: Josephson Effects in Superconductors (R. Gross, with K. Honasoge, W. K. Yam)
- FOPRA Experiment 108: Qubit Control and Characterization for Superconducting Quantum Processors (I. Tsitsilin, J. Feigl)

WS 2024/2025

- WMI Seminar on Current Topics of Low Temperature Solid State Physics (M. Althammer, F. Deppe, K. Fedorov, S. Filipp, R. Gross, S. Geprägs, H. Huebl, N. Kukharchyk, A. Marx, M. Opel, P. Rabl)
- Seminar: Novel Topics in Magnetism: quantum hybrid systems, spin dynamics, and angular momentum transport (M. Althammer, H. Huebl, N. Kukharchyk, M. Opel, S. Geprägs)
- Seminar: Advances in Solid-State Physics (M. Althammer, S. Geprägs, H. Huebl, M. Kartsovnik, A. Marx, N. Kukharchyk, M. Opel)
- Seminar: Quantum Science and Technology in Solids: spins, microwaves, and optomechanics (M. Althammer, M. S. Brandt, H. Huebl, S. Geprägs)
- Seminar: Journal Club on Quantum Systems (S. Filipp, C. Schneider)
- Seminar: Superconducting Quantum Circuits (S. Filipp, R. Gross, M. Werninghaus)
- Lecture: Superconductivity and Low Temperature Physics 1 (K. Fedorov)
- Problem Session: Superconductivity and Low Temperature Physics 1 (K. Fedorov)
- Lecture: Quantum Computing with Superconducting Qubits: basic concepts (C. Schneider, M. Werninghaus, S. Filipp)
- Problem Session: Quantum Computing with Superconducting Qubits: basic concepts (M. Werninghaus, C. Schneider)
- Lecture: Applied Superconductivity 1: from Josephson Effects to RSFQ Logic (M. Althammer)

- Problem Session: Applied Superconductivity 1: from Josephson Effects to RSFQ Logic (M. Althammer)
- Lecture: Quantum sensing (H. Hübl with M. Brandt, D. Bucher)
- Lecture: Magnetism (N. Kukharchyk)
- Problem Session: Magnetism (N. Kukharchyk with G. Mair)
- Seminar: Cavity-, Waveguide- and Circuit QED (P. Rabl)
- Quantum Tech Applications and Careers (S. Filipp, R. Cercola, D. Reichmuth)
- Quantum Ventures Practical Seminar (S. Filipp, R. Cercola, D. Reichmuth)
- Seminar: WMI Theory Seminar (P. Rabl)
- Theoretical Physics 4A (Statistical Mechanics and Thermodynamics) (P. Rabl)
- Problem Session: Theoretical Physics 4A (Statistical Mechanics and Thermodynamics) (P. Rabl)
- Open Tutorial: Theoretical Physics 4A (Statistical Mechanics and Thermodynamics) (P. Rabl)
- FOPRA Experiment 104: The Josephson Parametric Amplifier (JPA) (R. Gross, with K. Honasoge, W. K. Yam)
- FOPRA Experiment 16: Josephson Effects in Superconductors (R. Gross, with K. Honasoge, W. K. Yam)
- FOPRA Experiment 108: Qubit Control and Characterization for Superconducting Quantum Processors (J. Feigl)

Staff



Staff of the Walther-Meißner-Institute

Scientific Directors

Prof. Dr. Stefan Filipp

Prof. Dr. Peter Rabl (managing director)

Prof. Dr. Rudolf Gross

Deputy Director

Prof. Dr. Hans Hübl

Technical Director

Dr. Achim Marx

The technical director and the elected representative of the scientific staff (Dr. Matthias Opel) are members of the WMI Executive Committee and support the scientific directors in the management of the WMI.

Administration/Secretary's Office

Andrea Person

Carola Siegmayer

Dong Li

Emel Dönertas

Martina Meven

Scientific Staff

Priv.-Doz. Dr. Matthias Althammer

Dr. Vera Bader

Dr. Anirban Bhattacharjee

Priv.-Doz. Dr. Frank Deppe

Prof. Dr. Andreas Erb

Priv.-Doz. Dr. Kirill Fedorov

Dr. Noelia Fernandez

Dr. Louis Garbe

Dr. Stephan Geprägs

Dr. Mark Kartsovnik

Dr. Gleb Krylov

Dr. Nadezhda Kukharchyk

Dr. Klaus Liegener

Dr. Benjamin Lienhard

Dr. Jacquelin Luneau

Dr. Matthias Opel

Dr. Tahereh Parvini

Dr. Christian Schneider

Dr. Lasse Södergren

Dr. Max Werninghaus

Dr. Xin Zhan

M. Sc. Joan Agustí

M. Sc. Nicolas Arlt

M. Sc. Syeda Aliya Batool

M. Sc. Daniil Bazulin

M. Sc. Niklas Bruckmoser

M. Sc. David Bunch

M. Sc. Gesa Günneweber

M. Sc. Julian Englhardt

M. Sc. Jianpeng Chen

M. Sc. Shamil Erkenov

M. Sc. Julius Feigl

M. Sc. Florian Fesquet

M. Sc. Simon Gandorfer

M. Sc. Philippe Andreas Gigon

M. Sc. Niklas Glaser

M. Sc. Matthias Grammer

M. Sc. Maria-Teresa Handschuh

M. Sc. Kedar Honasoge

M. Sc. Karina Houska

M. Sc. Gerhard Huber

M. Sc. Kevin Kiener

M. Sc. Martin Knudsen

M. Sc. Leon Koch

M. Sc. Fabian Kronowetter

M. Sc. Thomas Luschmann

M. Sc. Georg Mair

M. Sc. Adrian Misselwitz

M. Sc. Manuel Müller

M. Sc. Yuki Nojiri
M. Sc. Patricia Oehrl
M. Sc. Frederik Pfeiffer
M. Sc. Lea Richard
M. Sc. João Henrique Romeiro Alves
M. Sc. Federico Roy
M. Sc. Korbinian Rubenbauer
M. Sc. Lukas Schamriss
M. Sc. Monika Scheufele
M. Sc. Johannes Schirk
M. Sc. Saya Schöbe
M. Sc. Malay Singh
M. Sc. Ana Strinic
M. Sc. Ivan Tsitsilin
M. Sc. Lucia Valor
M. Sc. Florian Wallner
M. Sc. Johannes Weber
M. Sc. Emily Wright
M. Sc. Wun Kwan Yam
M. Sc. Przemyslaw Zielinski

Technical Staff

Peter Binkert
M. Sc. Thomas Brenninger,
Julia Gollasch
Dieter Guratzsch
Astrid Habel
Dipl.-Ing. (FH) Josef Höß
Sebastian Kammerer

Jan Naundorf
Georg Nitschke
Mario Nodes
Alexander Rößl
Andreas Russo
Harald Schwaiger

Assistants

Sybilla Plöderl

Maria Botta

Guest Researchers

The Walther-Meißner-Institute welcomes a significant number of guests every year to strengthen international collaborations and intensify scientific exchange with leading places internationally.

1. **Dr. Werner Biberacher**
permanent guest
2. **Prof. Dr. Dietrich Einzel**
permanent guest
3. **Dr. Kurt Uhlig**
permanent guest
4. **Prof. Dr. Christian Schade**, Humboldt-Universität zu Berlin, Germany
25.1. - 26.1.2024
5. **Prof. Henrik M. Rønnow**, École Polytechnique Fédérale de Lausanne, Lausanne, Switzerland
25.04. - 26.04.2024
6. **Prof. Dr. Wolfgang Pfaff**, University of Illinois at Urbana-Champaign, Illinois, USA
13.06. - 14.06.2024
7. **Cesare Mattioli**, École Polytechnique Fédérale de Lausanne (EPFL), Lausanne, Switzerland
23.05. - 25.06.2024
8. **Prof. Juan-Jose Garcia-Ripoll**, CSIC, Madrid, Spain
05.08. - 08.08.2024
9. **Dr. Ilya Sheikin**, Laboratoire National des Champs Magnétiques Intenses, LNCMI-EMFL, Grenoble, France
25.09 - 30.09. 2024
10. **Dr. Benjamin D'Anjou**, Université de Sherbrooke, Sherbrooke, Canada
16.10. - 18.10.2024
11. **Dr. Takahiko Sekine**, Max-Planck-Institut für Festkörperforschung, Stuttgart, Germany
23.10 - 16.11. 2024
12. **Dr. Sina Zeitinoglu**, Vienna University of Technology, Vienna, Austria
07.11. - 08.11.2024
13. **Prof. Simone Felicetti**, ISC-CNR, Rome, Italy
04.12. - 06.12.2024

Scientific Advisory Board & Executive Committee



Scientific Advisory Board

According to the statutes of the Bavarian Academy of Sciences and Humanities (BAdW) the Scientific Advisory Board evaluates the quality of the scientific work of Walther-Meißner-Institute (WMI) and gives advice to its Executive Committee to provide scientific quality assurance. The Scientific Advisory Board regularly reports to the Research Committee of the BAdW.

The members of the Scientific Advisory Board include members of BAdW with appropriate scientific background, representatives of the two Munich universities (TUM and LMU), as well as leading national and international scientists. They are appointed by the Section III “Naturwissenschaften, Mathematik, Technikwissenschaften” of BAdW for five years. The scientific directors of WMI are consultive members of the WMI Scientific Advisory Board. The Scientific Advisory Board is headed by a chairperson and deputy chairperson. They are elected by the Section III “Naturwissenschaften, Mathematik, Technikwissenschaften” of BAdW for five years at the suggestion of the members of the WMI Scientific Advisory Board. The chairperson of the Scientific Advisory Board must be a member of BAdW.

The present members of the WMI Scientific Advisory Board are:

- **Vollhardt, Dieter**, chairman (BAdW, University of Augsburg)
- **Bloch, Immanuel**, deputy chairman (BAdW, LMU Munich and Max-Planck-Institute of Quantum Optics)
- **Abstreiter, Gerhard** (BAdW, Technical University of Munich)
- **Bühler-Paschen, Silke** (Technical University of Vienna)
- **Filipp, Stefan**, consultive member (Technical University of Munich)
- **Finley, Jonathan** (Technical University of Munich)
- **Gross, Rudolf**, consultive member (BAdW and Technical University of Munich)
- **Hänsch, Theodor** (BAdW, LMU Munich and Max-Planck-Institute of Quantum Optics)
- **Hartmann, Michael** (FAU Erlangen-Nuremberg)
- **Molenkamp, Laurens** (BAdW and University of Würzburg)
- **Rabl, Peter**, consultive member (Technical University of Munich)
- **Wallraff, Andreas** (ETH Zurich)
- **Weiss, Dieter** (University of Regensburg)

Executive Committee

The Walther-Meißner-Institute is headed by the board of scientific directors, which is responsible for the development and implementation of the research program. The scientific directors hold a full professor position at one of the Munich universities (TUM or LMU). They are appointed in a joint process of the respective university and BAdW. The scientific directors are supported by the deputy director, the technical director and an elected representative of the scientific staff. They are appointed by the Section III "Naturwissenschaften, Mathematik, Technikwissenschaften" of BAdW for five years at the suggestion of the members of the WMI Scientific Advisory Board.

The present members of the WMI Executive Committee are:

- **Filipp, Stefan**, scientific director
- **Gross, Rudolf**, scientific director
- **Rabl, Peter**, scientific director (managing director)
- **Hübl, Hans**, deputy director
- **Marx, Achim**, technical director
- **Opel, Matthias**, representative of the scientific staff

Contact:

Walther-Meißner-Institut
Bayerische Akademie der Wissenschaften
Walther-Meißner-Str. 8
D - 85748 Garching
GERMANY

Phone: +49 – (0)89 289 14202
Fax: +49 – (0)89 289 14206
E-mail: Sekretariat@wmi.badw.de

www.wmi.badw.de

Published by:

Walther-Meißner-Institut
Walther-Meißner-Str. 8, D - 85748 Garching
December 2024



Walther-Meißner-Institut
DER BAYERISCHEN AKADEMIE DER WISSENSCHAFTEN